



The NOTEBOOK

BOONTON RADIO CORPORATION · BOONTON, NEW JERSEY

CALIBRATION OF A UHF Q METER¹

AUG 21 1961

CHARLES G. GORSS, *Development Engineer*

Introduction

This paper describes the development of coaxial line impedance standards for the UHF Q Meter Type 280-A, a modified two-terminal Q measuring instrument. (These standards are currently being readied for production by BRC and will be available to customers in the near future.) Improved methods for machining pure copper are described. The methods of deriving the reactance and series resistance of the coaxial are also described.

The ideal way to establish calibration of an impedance measuring device and maintain that calibration in the field is to utilize a stable, intrinsically accurate, reliable, and easily used impedance standard. If more than one of these standards exist with various known values of impedance the calibration is more exact. What is more, if these standards can be duplicated by precise methods, duplicates can be placed in the field where they are needed. The 280-A UHF Q Meter is a device which needs such standards.

There is no precise instrument which will cross check measurements made by this instrument with the required accuracy in the frequency range of the 280-A (210-610 Mc). The resonating capacitance varies between 4 and 25 pf with $\pm 5\%$ accuracy.

The internal resonating capacitance accuracy indicates the need for accurate inductance standards to check the actual effective resonating capacitance the in-



Figure 1. Don Gann, BRC Lab Technician, Checks the 280-A UHF Q Meter with an Impedance Standard

ternal capacitor presents to the instrument terminals. What is more, the instrument measures circuit Q so that if the internal losses of the resonating capacitor are to be evaluated, the Q of the standard inductor must be well known. In this way the losses in the internal capacitor can be unwound. The standard must therefore be an inductor whose inductance and Q are both accurately known and preferably calculable from reliable physical relationships.

Design

The most logical calculable form for an inductance standard to assume is a coaxial line shorter than $\lambda/4$ and short circuited by a perfect short circuit. Ideally, there should be no dielectric other than air, the dimensions should be

precisely known, the metal completely homogeneous and of a precise conductivity, and the surface roughness should be nil compared with the skin depth.

WE ARE MOVING

Boonton Radio Corporation will be moving to its new plant and offices in August. Our new address and telephone number will be as follows:

Mailing Address: Boonton Radio Corporation
P. O. Box 390
Boonton, New Jersey

Address of Plant and Offices:
Boonton Radio Corporation
Green Pond Road
Rockaway Township, New Jersey

Telephone: OAKWOOD 7-6400

TWX: ROCKAWAY NJ 866

Effective date of the move will be announced subsequently.

YOU WILL FIND . . .

Calibration of A UHF Q Meter	1
Checking the New DME and ATC Airborne Equipment with the Navigation Aid Test Set	5
New FM Stereo Modulator Type 219-A	7
Editor's Note — Q Meter Winner	8

¹ This article will appear in the 1961 IRE International Convention Record.

THE BRC NOTEBOOK is published four times a year by the Boonton Radio Corporation. It is mailed free of charge to scientists, engineers and other interested persons in the communications and electronics fields. The contents may be reprinted only with written permission from the editor. Your comments and suggestions are welcome, and should be addressed to: Editor, THE BRC NOTEBOOK, Boonton Radio Corporation, Boonton, N. J.

The metal picked for this development was copper. Oxygen free, high conductivity copper was chosen for its purity and relative freedom of conductivity from the effects of cold working as well as its high conductivity; actually exceeding the conductivity of the IACS (International Annealed Copper Standard).

The standards are to be of essentially 3 basic parts: the outer conductor, the short circuit, and the inner conductor. The outer conductor is a straight cylinder into which the short circuit fits. The inner conductor fits into a hole in the short circuit. Each fit is made an interference fit. The parts are joined by shrinking the inner line in liquid nitrogen and inserting it into the outer line. These two are then shrunk and inserted into the outer line. The result is extreme pressure and virtually a welded contact without heat or solder to add resistance. To mount this structure to the terminals of the Q Meter, an outer flange is provided. This flange is soldered into place using high temperature solder. The flange is placed 1/4 inch from the end of the coax in order to allow for attachment of the removable mounting plate. This mounting plate clears the coax line by 10 thousandths of an inch and is 5 thousandths short of the end of the coax line. A 5 thousandths ridge is provided at the top for contact with the mounting surface. This assures contact of the coax line itself with the ground plane and not the brass plate. The contacts cover approximately 100° of arc. The gap between the copper line and the brass mounting plate tends to keep the currents in the copper piece. This structure and its relation to the mounting surface is shown in Figure 2.

In order to contact the hot stator, a precise hole is bored into the center of the center conductor. A solid coin silver set of spring fingers plugs into this hole. A 2-56 stud on the reverse side connects this with the high post. This is placed on the high post with a torque

of 35 inch ounces.

The calculability of this standard depends to a great extent now on how well the surface and dimensions agree with theoretical assumptions. The bulk dc conductivity of this copper checks out at 101% IACS. Theoretically this should be the conductivity used in calculating resistance in the surface where the current flows. This will be true if the surface is not rough, torn, or contaminated to a depth which is small compared with skin depth. This is assured by the methods used to machine the surface.

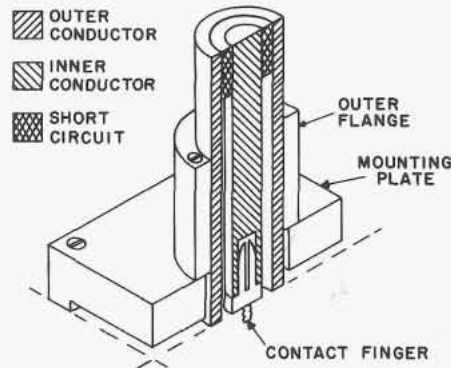

Figure 2. Cutaway View of Impedance Standard

Fabrication

In general, the proper machining of copper of this purity must be approached with a great deal of thought. Ordinary high-speed steel tools are quickly dulled by the abrasive nature of the copper to such an extent that accurate work is impossible. Silicon carbide can be used for preliminary shaping but it too is limited. All metal tools will tear the surface to a slight degree due to the tendency of the copper to stick to the tool and tear. The final cut of 1/2 thousandth of an inch must be cut with a diamond cutting tool. The finish obtainable from this type of tool with proper cutting rates is better than 4 microinches. The work was all done on a precision Hardinge toolroom lathe. The short circuit and the center conductor were cut in a conventional manner using the carbide and diamond tool. The outer conductor cylinder was cut out of a solid rod, first, by gun drilling within 10 thousandths. The tube was then mounted in a holder on the carriage which supported it over its full length. The boring tool was rotated between lathe centers and the carriage passed by it. Chips were forced out by continuous flow of coolant. The carbide tool was used in many fine successive

cuts until the bore was within 0.0005 inch of nominal. The diamond tool was then inserted in the bar precisely without disturbing the work. A single pass with the diamond tool brought the work to final size and finish.

After machining and assembly with precision jigs using liquid nitrogen for shrink fits, the entire piece was reduced in a hydrogen atmosphere at 230°C.

Credit should be given to the Bureau of Standards at Boulder, and in particular to Howard E. Bussey for the valuable assistance he gave us in the techniques of machining copper with diamond tools, and the further use of hydrogen reduction to maintain the surface conductivity.

Of course, no other surface finish is used. Plating or lacquer on the cleaned surface could only increase the losses in some nonrepeatable and nonpredictable manner. There is no evidence that electroplating can really approach the conductivity of the pure metal closely enough to use it for the conducting surface.

Evaluation

The highest frequency these standards are presently used at is 610 Mc. The skin depth in copper here is very close to 200 millionths of an inch. Since the surface finish is in the order of 4 microinches and of a regularly repeating nature, because the surface was developed by turning, the surface conductivity can be considered that of pure copper.

The calculation of the basic impedance of this structure is then undertaken from transmission line equations using reasonably exact relationships which take the copper losses into consideration. Basically, the impedance of a shorted transmission line can be given as:

$$Z = Z_0 \left[\frac{(\alpha \cos \beta l + j \sin \beta l)}{(\cos \beta l + j \alpha \sin \beta l)} \right] \quad (1)$$

$$\gamma = \alpha + j\beta \quad (2)$$

$$\alpha \approx \frac{R}{2\sqrt{L/C}} + \frac{G\sqrt{L/C}}{2} \quad (3)$$

$$R = \frac{1}{a} + \frac{1}{b} \sqrt{\mu_0 f / 4\pi\sigma} \quad (4)$$

$$\beta = \omega\sqrt{LC} \left(1 + \frac{R^2}{8\omega^2 L^2} \right) \quad (5)$$

$$Z_0 = \sqrt{L/C} \left[\left(1 + \frac{R^2}{8\omega^2 L^2} \right) + j \left(\frac{-R}{2\omega L} \right) \right] \quad (6)$$

$$L = \frac{\mu_0}{2\pi} \ln \frac{b}{a} \quad (7)$$

$$C = \frac{2\pi\epsilon}{\ln(b/a)} \quad (8)$$

$E = 8.855 \times 10^{-12}$ farads/meter

$\mu_0 = 4\pi \times 10^{-7}$ henrys/meter

$\sigma = 5.85 \times 10^7$ mhos/meter

l = length of line

a = radius of inner conductor

b = inner radius of outer conductor

These relationships give the series reactive and resistive components of the basic coaxial inductors.

This picture would be complete if the device were attached to a coaxial device. However, the Q Meter is an unbalanced device and a discontinuity will exist at the junction of the standard line and the Q capacitor terminal. Figure 3 illustrates the standard line superimposed upon the high terminals. The unbalanced currents result in excess inductance and resistance in the Q standard. The presence of the high post in the field of the line places a discontinuity capacitance across the line end. The exact calculation of these values would be very laborious because of the strange discontinuity configuration.

As a result of this limitation, a series of measurements were made which would define the reactive components, and, from an experimental knowledge of the reactive components, predict the effect of the current around the junction and then calculate the most probable excess resistance. The internal inductance of the resonating capacitor was first measured, at all settings in use, by short circuiting the terminals with a strap which covered the full 1/2 inch width of the terminals which are only 0.018 inch apart. When shorted, the resonant frequency of the structure was measured using lightly coupling probes which are a part of the Q Meter. The frequency was accurately measured with an electronic counter. The low frequency capacitance was then determined by comparing the same settings with a GR 722D precision capacitor and a precision bridge. From the capacitance and resonating frequency series L was computed

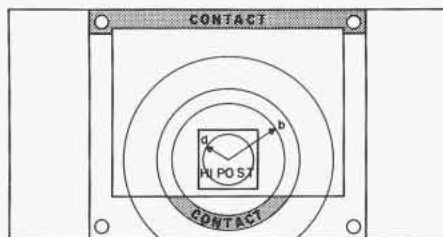

Figure 3. Standard Line Superimposed Upon the High Q Capacitor Terminals of the 280-A

$$L = \frac{1}{4\pi^2 f_o^2 C}$$

The effective X_C present at the terminals at a given test frequency would then be $X_C - X_L$. This then gave a reliable RF figure for X of the internal capacitor.

A series of measurements was then made of the resonating capacitance of various length lines at various frequencies within the range 210-610 Mc. Since the inductance of the coaxial standard could be computed from dimensions, and the X_C of the capacitor could be computed from series resonant frequency and low frequency capacitance, the discrepancy between X_L and X_C could be attributed to the presence of the discontinuity L and C. By graphical plotting it was possible to determine values of L_d and C_d which resulted in better than 2% agreement between the computed X_L and the computed X_C at all frequencies in the 210-610 Mc range. The discrepancy remaining could most likely be reduced by using a more complicated model but this is quite satisfactory for reactance calibration of a 5% instrument. As a result of this experiment, L_d was set at 0.60 nanohenry and C_d at 0.2 picofarad.

The next step is to use this knowledge in a calculation of the most probable discontinuity resistance. It is assumed that the current at the end of the coax line is at its maximum where the perimeter of the line actually contacts the ground stator. However, current does not stop at the end of this area but most likely tapers off gradually toward the non-contacting side because current flows on the end of the coax line. The asymmetrical current flow results in higher order TE modes. If the amplitude of these higher modes were known at the boundary, the value at any other point up the line is approximated by n nepers attenuation per average radius since the line is well beyond cutoff for these modes; where n is the order of the modes being considered. An integration

of the excess mean squared current vs. axial travel up the line permits determination of total excess loss due to the presence of higher order TE mode waves. This excess loss can be expressed as an equivalent resistance in series with the TEM mode model of the reactance standard.

Assume that axial current at the discontinuity has a known distribution around the periphery represented by Fourier Series of

$$\frac{1}{2\pi b} \left[1 + P_1 \cos \phi + P_2 \cos 2\phi + P_3 \cos 3\phi + \dots + P_n \cos n\phi + \dots \right]$$

Assume further the coax line has 50 ohms characteristic impedance, and the frequency is very much less than the cutoff frequency of the higher modes. Then:

$$L_d = 2.22 \times 10^{-9} \sum K_L P_n$$

where $b = 0.0111$ meters

$$R_d = r_s \sum K_r (P_n)^2$$

Using the above relationships a number of plausible distributions were tested for which the Fourier coefficient are known. From this a relationship was developed which fits most distributions within a $\pm 5\%$ error. This is quite satisfactory, since the total correction is only a small part of the total resistance. The approximate relationship between L_d and R_d is as follows:

$$\frac{R_d}{r_s} = 0.126 \times 10^9 [L_d]^{1.4}$$

r_s = surface resistivity ohms/sq.

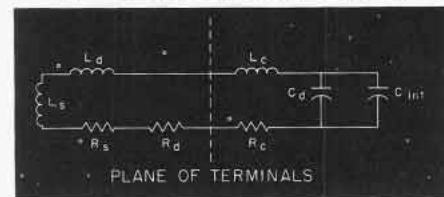

Figure 4. Equivalent Circuit with Impedance Standard Connected to 280-A Q Capacitor Terminals

Until such time as the actual current distribution can be established this relationship will do quite well. As a typical situation, where the discontinuity resistance is 1/10 the resistance of the TEM line, the error in Q will only be 1% if a 10% error in R_d exists. This is certainly in line with the present state of development of these standards.

Credit must be given here to Bernard D. Loughlin, Electronic Research Consultant, Huntington, Long Island, for

developing this method of evaluating the discontinuity parameters and for his many invaluable contributions to the concept of the standards.

Measuring Technique

The method in which these devices are used will also contribute to their precision as standards. As previously mentioned the contact button screws into the center hole of the high capacitor stator. When this is inserted it must be clean. It must be also be seated with a precise torque value of 35 inch ounces. This torque value will not break the 2-56 stud and yet makes adequate contact so as to assure no Q deterioration. The value was derived experimentally as that value which is 25% above the torque value where no readable change occurs with additional torque.

The four screws which hold down the mounting flange are also tightened to this torque. Care is taken to tighten each of the four screws a little at a time and in succession. This is to assure that the standard line is seated properly on the Q capacitor.

The temperature of the copper is also monitored with a thermocouple during the measurement to allow corrections for conductivity and dimension changes which occur with changes in temperature.

The Q is measured by determining the frequency interval between the 3 db points on the resonance curve. The 280-A Q Meter is equipped to measure this internally and, as well, provides an external monitor jack to be used with a precision counter. Q is equal to the frequency at the peak of the curve divided by the bandwidth.

Application

The significant applications of these standards are as calculable Q standards on the UHF Q Meter and as a means for evaluating the internal losses in the self-contained resonating capacitor of the 280-A. A knowledge of the effective inductance of the coaxial standard, as previously described, will define what capacitance should resonate with the standard at a given frequency and thereby give a precise standard for checking capacitor calibration. However, computing the series resistance of the internal capacitor in the 280-A from a knowledge of measured circuit Q is a more involved procedure. Q is fundamentally defined as:

$$Q = \omega_0 \times \frac{\text{Energy stored in ckt.}}{\text{Average power lost}}$$

One may sum the power stored in the inductive reactance of the line and the two lumped reactances $L_d + L_c$. If Q is divided into the product of ω_0 and this total stored energy, the average power lost will be derived. If the power loss in the line is summed and added to the power loss in the discontinuity, the remaining power loss would be attributable to the series resistance of the capacitor. The derivation of this resistor is as follows:

$$Q = \omega_0 \frac{\text{Energy stored}}{\text{Avg. power loss}}$$

Lumped Inductance $L_t = L_c + L_d$

Lumped Resistance $R_t = R_c + R_d$

$V_1 =$ Voltage of transmitted wave

$$I = \frac{2V_1}{Z_0} \cos \beta l$$

Energy stored in line Inductance

$$U_m = \frac{L}{2} \int_0^l \frac{4V_1^2}{Z_0^2} \cos^2 \beta l \, dl$$

$$= \frac{2V_1^2}{Z_0^2} L \left[\frac{l}{2} + \frac{1}{4\beta} \sin 2\beta l \right]_0^l$$

Energy stored in Lumped Inductance

$$U_L = \frac{1}{2} L_t \times \frac{4V^2}{Z_0^2} \cos^2 \beta l$$

$$= \frac{2V_1^2}{Z_0^2} L_t \cos^2 \beta l$$

Average Energy Lost in Line

$$W_R = \int_0^l \left[\frac{2V_1 \cos \beta l}{Z_0} \right]^2 \frac{R}{2} \, dl$$

$$= \frac{2V_1^2}{Z_0^2} R \int_0^l \cos^2 \beta l \, dl$$

$$= \frac{2V^2 R}{Z_0^2} \left[\frac{l}{2} + \frac{\sin 2\beta l}{4\beta} \right]_0^l$$

Average Energy Lost in Lumped Resistance

$$W_{RL} = \frac{I^2 R}{2} = \frac{4V_1^2}{Z_0^2} \cos^2 \beta l \frac{R_T}{2}$$

$$= \frac{2V^2}{Z_0^2} R_t \cos^2 \beta l$$

Then Summing Stored Energy and Average Power Loss and cancelling term:

$$Q = \omega_0 \frac{\frac{2V_1^2}{Z_0^2}}{\frac{2V_1^2}{Z_0^2}}$$

$$Q = \omega_0 \frac{\left[\frac{L}{2} + \frac{L}{4\beta} \sin 2\beta l + L_t \cos^2 \beta l \right]}{\left[\frac{Rl}{2} + \frac{R}{4\beta} \sin 2\beta l + R_t \cos^2 \beta l \right]}$$

$$Q = \omega_0 \frac{\left[\frac{2L\beta l + L \sin 2\beta l + 4\beta l + \cos^2 \beta l}{2R\beta l + R \sin 2\beta l + 4\beta R + \cos^2 \beta l} \right]}{\left[\frac{2R\beta l + R \sin 2\beta l + 4\beta R_T \cos^2 \beta l}{\omega_0} \right]}$$

$$R_c = R_t - R_d = \frac{\omega_0 [2L\beta l + L \sin 2\beta l + 4\beta l + \cos^2 \beta l]}{4\beta Q \cos^2 \beta l} - \left[\frac{2R\beta l + R \sin 2\beta l}{4\beta \cos^2 \beta l} \right]$$

The resistance derived by this method can be considered in series with the internal Q capacitor. For precise measurements of external high Q components, this resistance and the series inductance of the capacitor must be considered in series with the externally connected circuit. With this knowledge, the Q of a capacitor can be measured whose losses may be even less than the internal Q capacitor. Without the internal C loss, such a capacitor might even seem to be one with negative losses; and the result would be meaningless.

The present standards under development include 7 different lengths which are designed to be used as a check at high, medium, and low frequencies in the 210-610 Mc range; with 3 capacitance values at each of the three frequencies. These are able to describe a relatively accurate picture of the internal resonating capacitor.

Future Work

As a future check on the relationship between the conductivity of the copper

and its performance in the skin of the line, a long line, shorted at both ends, will be constructed from the same copper and machined by the same methods. By means of tiny probes through the wall of the tube, the resonant frequency as a half wave resonator and the bandwidth can be determined. This will give the Q and hence the surface resistivity working backward from the relationship

$$Q = \beta/2\alpha.$$

This experiment will give an independent check on the conductivity of the copper in the surface, free from the effects of any discontinuities. This is of interest as a final check on the use of these as standards. All previous work has assumed that conductivity at RF is equal to the dc value. This is accurate, most likely, to within two percent (2%) but it will be of great value to verify this experimentally and will perhaps improve the absolute accuracy by some measurable degree.

Checking The New DME And ATC Airborne Equipment With The Navigation Aid Test Set

WILLARD J. CERNEY, Sales Engineer

The BRC Navigation Aid Test Set Type 235-A provides all of the RF circuitry required for bench testing the new ATC (Air Traffic Control) transponders and DME (Distance Measuring Equipment) portions of the VORTAC navigation system. The test set (Figure 1) contains three basic interconnected units: a crystal-controlled RF signal generator, a peak pulse power comparator, and a wavemeter. The wavemeter is used for measuring the frequency of the ATC Transponder transmitter, and the signal generator and power meter are used for making both ATC and DME measurements.

An engineering description of the 235-A is given in Notebook Number 24. This article will describe some measurements that can be made with the test set when it is used with the Collins Radio Company's 578X-1 Transponder Bench Test Set or the 578D-1 DME Bench Test Set, and a suitable oscilloscope. Before these measurements are described, a brief history of the navigation aid systems will be given.

Conclusion

In summary, the devices described above are stable repeatable standards of impedance specifically for use on the 280-A UHF Q Meter. They are useful for laboratory and field calibration of this instrument within 2% of reactance and very close to that in Q. Further investigation of these pieces should place the Q value within 5%. However, the knowledge of such a small resistance in series with such a high reactance will always have uncertainties. The techniques used here are applicable to standards for any similar impedance measuring system, and in a sense are more applicable to coaxial systems because of the simpler discontinuity picture. Like any standardizing program, this is a continuing one. The needs for better standards are constant. The advances in techniques of copper machining and fabrication described here are not an end in themselves, nor are the methods of analysis, which should be improved by future study.

These systems were used for navigating aircraft during cross-country flights, for orienting aircraft at or near the airport, and for instrument landings. Later a system was developed which provided a new and improved technique for instrument landings. This system was called ILS (Instrument Landing System). VOR, a system for measuring bearing to a radio station, was introduced a short time later. The new ILS and VOR systems operate in the VHF region. BRC's types 211-A and 232-A signal generators were designed specifically for use in checking the ILS and VOR systems.

About that same time, FAA put into service Airport Surveillance Radar (ASR) equipment to navigate aircraft in case of loss of radio contact with ground stations, and Precision Approach Radar (PAR) equipment to aid in the landing of aircraft without ILS or with ILS which was not working properly.

These navigation aid systems have played an important part in commercial, military, and private air travel, and should be given a good deal of credit for air travel being as safe as it is today. However, with more and faster aircraft being put into service everyday, the need for new and faster techniques for navigating and identifying aircraft became apparent. Recognizing this need, FAA, in conjunction with the military, installed a new system designed to give not only bearing but range to the radio station. This system, called TACAN, has been installed by the Government at the same locations as the VOR equipment. The two systems may also be combined to form a hybrid system known as

NAVIGATION AID SYSTEMS

The first radio navigation aids for aircraft were the low-frequency radio direction finder and radio range equip-

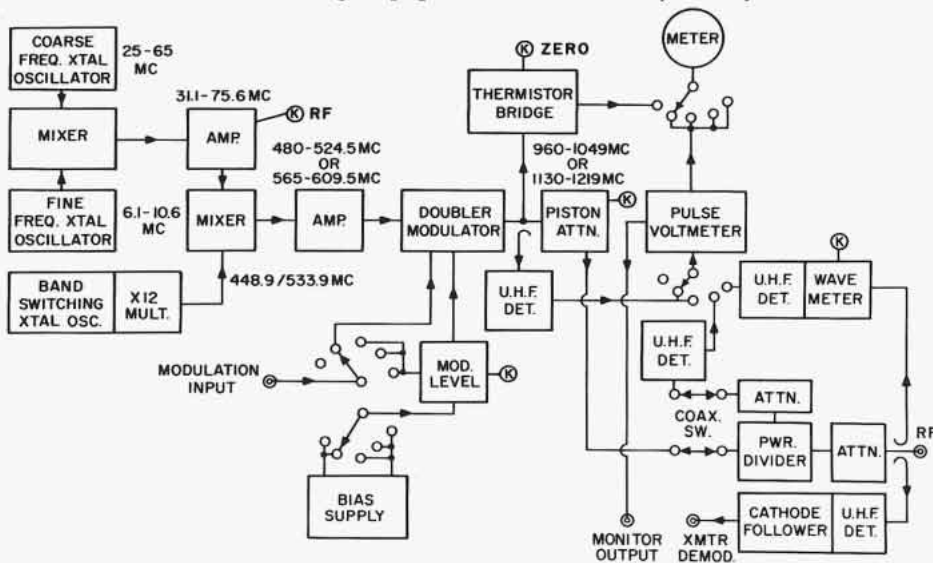

Figure 1. Block Diagram of Type 235-A

VORTAC; with the VOR transmitter being used to determine bearing and the TACAN system being used to determine the distance from the aircraft to the ground station.

The ATC transponder is an automatic receiver-transmitter installed in the aircraft. (This system is similar to the IFF system used during World War II.) When the Air Traffic Controller on the ground wishes to identify an airborne plane, he merely presses a button on his radar console. This operates a radio circuit which automatically transmits a series of coded interrogation pulses to the receiver in the aircraft. A series of coded reply pulses is then automatically sent to the ground station from the plane's transmitter, and appears on the Air Traffic Controller's radar scope. The system is positive and fast enough to fill the requirements of the fast-flying aircraft in use today.

DME MEASUREMENTS

A typical DME radio set consists of an interrogation generator or synchronizer, an encoder, a modulator transmitter-receiver, a decoder, distance measuring circuits, and the indicator and controls in the cockpit. DME measurements which can be made with the Navigation Aid Test Set Type 235-A may be broken down in three groups; transmitter characteristics, receiver characteristics, and distance measuring circuit measurements. The basic setup for performing DME measurements is shown in Figure 2.

Transmitter Power

The 235-A measures, on a comparison basis, the peak power of the pulse train transmitted from the DME equipment. First, the peak of the DME transmitter is measured in a pulse voltmeter circuit and read out on a panel meter. The pulse voltmeter and detector are then switched to read the calibrated output of the signal generator through an adjustable precision attenuator which is adjusted to provide the same level measured for the DME transmitter. The power level is read directly on an attenuator dial.

Transmitter Pulse Characteristics

Certain pulse shapes and positions are required to insure proper operation of the DME transmitter. The following typical DME pulse requirements can be checked with the 235-A, the DME mod-

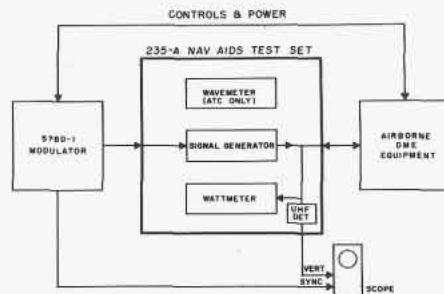

Figure 2. Basic setup for DME Measurements

ulator, and an oscilloscope of suitable dynamic range.

Pulse Characteristic	Typical Requirement (Nominal)
Rise Time	2.5 μ sec
Fall Time	2.5 μ sec
Duration	3.5 μ sec
Pulse Top	5% of maximum amplitude
Repetition Rate	150 pulse pairs (in search position) 30 pulse pairs (in track position)

Receiver Sensitivity

A typical DME receiver sensitivity requirement is that the receiver be capable of locking on a fixed distance 9 out of 10 times. This requirement can be checked with the 235-A, used in conjunction with the DME modulator.

Distance Measuring and Memory Circuits

The functions of the distance measuring circuits are to search for a returned pulse, lock on, maintain lock on in case of momentary loss of signal, and to read out distance. The 235-A, in conjunction with the DME modulator, will check that the search time, memory and prememory time, and distance accuracy are within the tolerances specified by the DME equipment manufacturer.

ATC MEASUREMENTS

A typical ATC transponder consists of a receiver, decoder, encoder, modulator, transmitter, and the necessary cockpit controls. ATC measurements may be broken down in three groups: receiver characteristics, decoder and encoder characteristics, and transmitter characteristics. The basic setup for making ATC measurements is shown in Figure 3.

Receiver Sensitivity

A typical requirement for ATC receiver sensitivity, is that the ATC transponder should give at least 90% replies with a signal level of -74 dbm, and that the sensitivity should be reduced a nominal 12 db for low-sensitivity operation. This requirement can be checked with the 235-A.

Receiver Bandwidth

To measure receiver bandwidth, an oscilloscope is connected to the monitor output connector on the 235-A test set. With the signal generator output set at the level where the ATC transponder is just triggered at center frequency, the attenuator reading is noted. The signal generator output frequency is then changed the desired amount, and the signal generator output is increased until the transponder just triggers again. The difference in attenuator indication is the attenuation for the frequency increment used.

Receiver Dead Time

To check receiver dead time, the second interrogation delay control on the ATC modulator is adjusted so that a full display of second interrogation pulses is observed on the oscilloscope and the receiver response time is measured. A typical requirement is that the receiver be capable of responding in not less than 25 μ sec nor more than 145 μ sec after the first pulse of the first reply group.

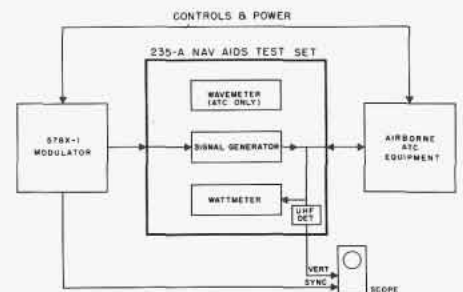

Figure 3. Basic setup for ATC Measurements

Decoder Tolerance

The function of the ATC decoder is to reject all improper signals, such as random pulses, sidelobe pulses, reply pulses from other equipment, etc., that may resemble an interrogating pulse. The decoder pulse spacing is checked by varying the interrogation pulse spacing control on the ATC modulator in a plus and minus direction and observing that

the spacing, as displayed on the oscilloscope, is within the tolerances specified. The ability of the decoder to reject sidelobe interrogations is checked by varying the amplitude of the second pulse. The pulse width capability is checked by varying the width of either pulse.

Encoder Measurements

The primary purpose of the ATC encoder is to produce selected reply codes. Presently, there are 64 different reply codes which are set up binarily. Each reply code is made up of 2 framing pulses and 6 code pulses. The spacing between the framing pulses and the code pulses must be within specified tolerances. The 235-A, in conjunction with the ATC modulator and an oscilloscope, can be used to check these tolerances.

Transmitter Frequency

The frequency of the ATC transponder is measured by adjusting the wavemeter in the 235-A for a maximum

indication on the front panel meter, with the function selector set for frequency measure operation, and reading the frequency on the wavemeter dial.

Transmitter Power and Pulse Characteristics

The ATC transponder power and pulse characteristic measurements are made in the same manner as the DME transmitter power and pulse characteristic measurements. Pulse characteristic requirements are obtainable from the ATC equipment handbook.

SPECIAL MEASUREMENTS

The measurements described in this article are the basic measurements which can be made using the 235-A. Other measurements such as overall transponder delay, AGC characteristics, AOC measurements, etc., may also be made. Complete ATC and DME measurement procedures are given in the 235-A instruction book and in the instruction books for the ATC and DME equipment.

channels may be switched in or out of circuit

*per Section 3.322 h, FCC Docket 13506

SUBSIDIARY COMMUNICATIONS

Frequency: 20 to 75 kc

Metering — A meter is provided to read the multiplex output in terms of percent of system deviation* of the main RF carrier. The unit is factory adjusted to operate with the Type 202-E Signal Generator. (Alternative adjustment may be made for use with other signal generators.)

*100% = 75 kc deviation

Composite Output — A suitable linear adder is provided to permit summing the monaural channel, pilot carrier, stereo channel, and subsidiary communications FM sub-carriers.

Power Supply — 115 volts ±10%, 60 cps.

HANS SCHLOTT JOINS BRC SALES STAFF

The appointment of Hans Schlott as Regional Sales Manager for BRC was announced in March of this year. In this capacity Hans will direct the BRC sales operations along the east coast from the Metropolitan New York City area south to the Metropolitan Washington D.C. area. Beginning his association with the Company in March proved timely for Hans, as it afforded him the opportunity to serve in the BRC booth at the IRE show. Here he met scores of BRC customers and was able to hear, first hand, their problems concerning measurement instrumentation.

Hans, a native of Sweden, came to the United States in 1949. He graduated from the Charlottenburg Institute of Technology in Berlin, Germany and is an Applied Physicist. He also completed studies in Industrial Management at the Graduate Business School of St. Gall, Switzerland.

Prior to his association with BRC, Hans served with Curtiss Wright's Princeton Division as Senior Sales Engineer, Eastern Territory. Before that he was Eastern Sales Manager for the New Products Division of the Corning Glass Works in New York City.



HANS SCHLOTT

NEW FM STEREO MODULATOR TYPE 219-A

With the recent FCC approval (Docket 13506) of a system providing entertainment stereo and subsidiary communications in the 88 to 108 Mc FM broadcast band, a definite requirement has developed for a suitable modulator to generate the specified multiplex signals to, in turn, modulate an FM signal generator for the testing of receiving systems.

The new Type 219-A FM Stereo Modulator is designed to provide stereo modulation outputs as specified in the FCC Docket, suitable for modulating the BRC Type 202-E FM-AM Signal Generator or other FM signal generators with adequate modulation characteristics. Provision is made for Left (L) and Right (R) audio stereo channel inputs and/or subsidiary communications FM subcarriers in the 20 to 75 kc range. Preliminary specifications for the Type 219-A are given below.

Input Characteristics

ENTERTAINMENT STEREO

Source: Left (L) and Right (R)

Fidelity: 50 cps to 15 kc

Modulating Oscillator: an internal 1 kc oscillator is provided which, in conjunction with the Type 202-E internal modulating oscillator (50 cps to 10 kc) may be used to furnish stereo inputs.



Type 219-A

SUBSIDIARY COMMUNICATIONS

Source: FM sub-carriers

Frequency Range: 20 to 75 kc

Output Characteristics

ENTERTAINMENT STEREO

Pilot Carrier — Frequency: 19 kc
Accuracy: ±0.01%
Level: 9% of system deviation

Double Sideband Suppressed Carrier (L-R)

Frequency: 38 kc

Accuracy: ±0.01%

Fidelity: 50 cps to 15 kc

Carrier Suppression: <1% of system deviation

Sideband Level: 45% of main carrier modulation with either Left (L) or Right (R) signal

Distortion: <1% at a level corresponding to 45% of system deviation

Monaural Carrier (L + R)

Frequency: 50 cps to 15 kc

Preemphasis: Standard* preemphasis for main (L + R) and stereo (L—R)

EDITOR'S NOTE

The Q of the resonant circuit displayed at the IRE show is 524.2. Winner of the Q Meter, with an estimate of 523.5, is Mr. E. B. Sussman, an Engineering Consultant from Livingston, N. J.

More than 1000 entries were submitted, with Q estimates ranging from 1 to 20,000. The bar graph below shows the distribution of these estimates. There were nine estimates in addition to the winning estimate which were very close to the actual measured Q and are certainly deserving of honorable mention.

Estimate	Submitted By
515	E. Queen, Stuyvesant High School, N.Y.C.
521	H. Korke, CBS Radio, N.Y.C.
521	J. M. J. Madey, Student, Clark, N. J.
521.5	P. H. Daitch, Microwave Research Inst., Brooklyn, N. Y.

- 523 J. F. Isenberg, Jr., IBM, Poughkeepsie, N. Y.
- 523.5 E. B. Sussman, Engineering Consultant, Livingston, N. J.
- 525 M. Gellu, FAA/NAFEC, Atlantic City, N. J.
- 527 J. Brady, Cooperative Ind., Inc., Chester, N. J.
- 527 P. Bahr, Schon Tool & Machine Co., Inc., Union, N. J.
- 528 A. Karr, Daystrom Central Research Lab., W. Caldwell, N. J.

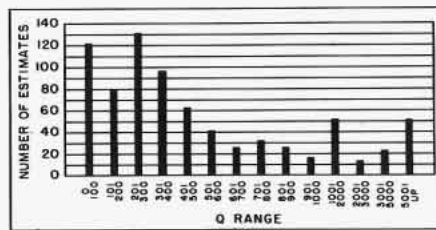

Distribution of Q Estimates.

The resonant circuit in question was measured by means of the "in-circuit" technique on the UHF Q Meter Type 280-A at 500 megacycles. Six separate measurements were made on the most sensitive range on the instrument. The average of these measurements was 524.2.

Our congratulations to Mr. Sussman and many thanks to our many friends who visited with us at the show.

NEELY ENTERPRISES APPOINTED NEW BRC SALES REPRESENTATIVE

The appointment, effective April 1st, of Neely Enterprises as Sales Representatives for Boonton Radio Corporation was recently announced. Neely maintains eight offices in the states of California, New Mexico, and Arizona. A list of these offices is given on page 8 under BRC Engineering Representatives. If you live in one of these states, there is a Neely office conveniently near you. All offices are fully staffed to help fill your electronic needs.

Engineering  *Representatives*

ALBUQUERQUE, New Mexico
NEELY ENTERPRISES
6501 Lomas Blvd., N.E.
Telephone: ALpine 5-5586
TWX: AQ-172

ATLANTA, Georgia
BIVINS & CALDWELL, INC.
3110 Maple Drive, N.E.
Tel. Atlanta, Georgia 233-1141
TWX: AT 987

BINGHAMTON, New York
E. A. OSSMANN & ASSOC., INC.
149 Front Street
Vestal, New York
Telephone: STillwell 5-0296
TWX: ENDICOTT NY 84

BOONTON, New Jersey
BOONTON RADIO CORPORATION
50 Intervale Road
Telephone: DEarfield 4-3200
TWX: BOONTON NJ 866

BOSTON, Massachusetts
INSTRUMENT ASSOCIATES
30 Park Avenue
Arlington, Mass.
Telephone: MIsson 8-2922
TWX: ARL MASS 253

CHICAGO 45, Illinois
CROSSLEY ASSOC., INC.
2501 W. Peterson Ave.
Telephone: BRoadway 5-1600
TWX: CG508

CLEVELAND 24, Ohio
S. STERLING COMPANY
5827 Mayfield Road
Telephone: HILLcrest 2-8080
TWX: CV 372

DALLAS 9, Texas
EARL LIPSCOMB ASSOCIATES
3605 Inwood Road
Telephone: FLEetwood 7-1881
TWX: DL 411

DAYTON 19, Ohio
CROSSLEY ASSOC., INC.
2801 Far Hills Avenue
Telephone: AXminster 9-3594
TWX: DY 306

DETROIT 35, Michigan
S. STERLING COMPANY
15310 W. McNichols Rd.
Telephone: BRoadway 3-2900
TWX: DE 1141

EL PASO, Texas
EARL LIPSCOMB ASSOCIATES
720 North Stanton Street
Telephone: KEystone 2-7281

HARTFORD, Connecticut
INSTRUMENT ASSOCIATES
734 Asylum Avenue
Telephone: CHapel 6-5686
TWX: HF 266

HIGH POINT, North Carolina
BIVINS & CALDWELL, INC.
1923 North Main Street
Telephone: High Point 882-6873
TWX: HIGH POINT NC 454

HOUSTON 5, Texas
EARL LIPSCOMB ASSOCIATES
3825 Richmond Avenue
Telephone: MOhawk 7-2407
TWX: HO 967

HUNTSVILLE, Alabama
BIVINS & CALDWELL, INC.
Telephone: 534-5733
(Direct line to Atlanta)

INDIANAPOLIS 20, Indiana
CROSSLEY ASSOC., INC.
5420 North College Avenue
Telephone: CLifford 1-9255
TWX: IP 545

LAS CRUCES, New Mexico
NEELY ENTERPRISES
114 South Water Street
Telephone: JACKson 6-2486
TWX: LAS CRUCES NM 5851

LOS ANGELES, California
NEELY ENTERPRISES
3939 Lankershim Blvd.
North Hollywood, California
Telephone: TRIangle 7-0721
TWX: N-HOL 7133

ORLANDO, Florida
BIVINS & CALDWELL, INC.
P.O. Box 6941
601 N. Fern Creek Drive
Telephone: CHerry 1-1091
TWX: OR 7026

OTTAWA 4, Ontario, Canada
BAYLY ENGINEERING, LTD.
80 Argyle Ave.
Telephone: CEntral 2-9821

PHOENIX, Arizona
NEELY ENTERPRISES
641 East Missouri Avenue
Telephone: CRestwood 4-5431
TWX: PX 483

PITTSBURGH 27, Pennsylvania
S. STERLING COMPANY
4232 Brownsville Road
Telephone: TUxedo 4-5515

PORTLAND 9, Oregon
ARVA, INC.
1238 N.W. Glisen Street
Telephone: CAPItal 2-7337

RICHMOND 30, Virginia
BIVINS & CALDWELL, INC.
1219 High Point Avenue
Telephone: ELgin 5-7931
TWX: RH 586

ROCHESTER 25, New York
E. A. OSSMANN & ASSOC., INC.
830 Linden Avenue
Telephone: LUDlow 6-4940
TWX: RO 189

SACRAMENTO, California
NEELY ENTERPRISES
1317 Fifteenth Street
Telephone: GILbert 2-8901
TWX: SC 124

SAN DIEGO, California
NEELY ENTERPRISES
1055 Shafter Street
Telephone: ACAdemy 3-8103
TWX: SD 6315

SAN FRANCISCO, California
NEELY ENTERPRISES
501 Laurel Street
San Carlos, California
Telephone: LYtell 1-2626
TWX: S CAR-BEL 94

SEATTLE 9, Washington
ARVA, INC.
1320 Prospect Street
Telephone: MAIn 2-0177

SPOKANE 10, Washington
ARVA, INC.
East 127 Augusta Avenue
Telephone: FAirfax 5-2557

ST. PAUL 14, Minnesota
CROSSLEY ASSOC., INC.
842 Raymond Avenue
Telephone: MIldway 6-7881
TWX: ST P 1181

SYRACUSE, New York
E. A. OSSMANN & ASSOCIATES, INC.
P. O. Box 128
101 Pickard Drive
Telephone: GLenview 4-2462
TWX: SS 355

TORONTO, Ontario, Canada
BAYLY ENGINEERING, LTD.
Hunt Street, Ajax, Ontario, Canada
Telephone: AJax, Whitehall 2-1020
(Toronto) 925-2126

TUSCON, Arizona
NEELY ENTERPRISES
232 South Tuscon Blvd.
Telephone: MAIn 3-2564
TWX: TS 5981

VANCOUVER 9, B. C. Canada
ARVA, INC.
1624 West 3rd Avenue
Telephone: REgent 6-6377