

P6015A High-Voltage Probe



High Voltage – 1.5 KV to 20 KV
DC/40 KV Peak (100 mS pulse width)

High Bandwidth – 75 MHz

Silicone Dielectric (no freon)

Optional 1,000X Coding

Wide Compensation Range
(7 to 49 pF)

Heavy-Duty, Versatile Ground Lead
and Clip

Small Compensation Box
for Use with Multi-input Instruments

Flexible, Durable Cable

For high-performance, high-voltage measurements, the P6015A Probe sets the standard. With a bandwidth of 75 MHz and maximum peak voltage rating of 40 kV, the P6015A is your only choice for high-frequency high-voltage measurements.

Environmentally Safe

The CFC 114 dielectric often used in high-voltage applications has been replaced with a silicone compound.

Small Compensation Box

Two P6015A compensation boxes easily fit on all plug-in amplifiers and oscilloscope inputs. While two P6015As are not a balanced differential probe pair, they do have an attenuation adjustment and may be a reasonable solution for high-voltage differential measurements. Our tests indicate a CMRR of around 250:1 at 1 MHz on the 11A33 Differential Comparator. The wide compensation range makes the P6015A compatible with all Tektronix differential amplifiers.

1,000X Coding

1,000X coding is available as an option on both the 10-foot and 25-foot versions. Tektronix digital storage oscilloscopes and 11000 Series plug-ins correctly recognize the coding resistor as 1,000X attenuation. Using the optional 1,000X coding BNC with other read-out scopes may result in an erroneous readout display.

7 to 49 pF Compensation Range

The P6015A will compensate with all Tektronix and almost all other manufacturers' oscilloscopes – even with more recent scopes with input capacitance as low as 7 pF.

Heavy Duty Ground Leads

Our customers have told us that they need to attach to large circuit connection points. So we use a heavy-duty ground lead and crocodile clip. The flexible ground

Design and Test Application Areas

Following are some of the typical applications for the P6015A:

- Auto ignition
- Transformers
- Circuit breakers
- Surge protectors
- Lighting strike evaluation
- Avionics: radar, magnetrons, traveling wave tubes
- Electric ground transportation vehicles
- Semiconductor production equipment

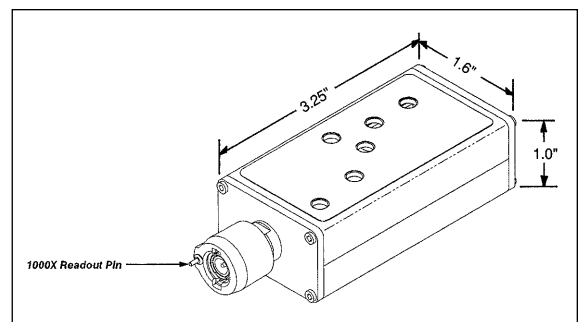

Compensation Box with Readout Option

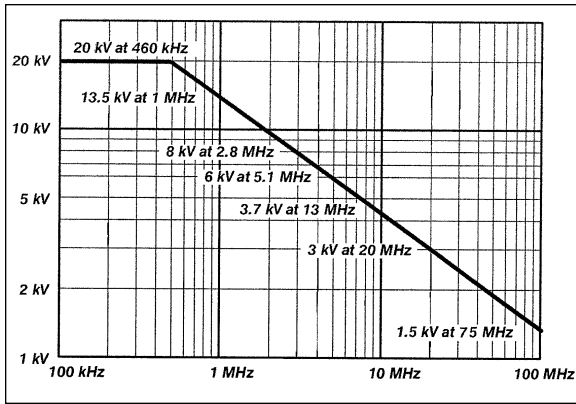

Figure 1. Maximum Input Voltage Derating (DC + Peak AC).

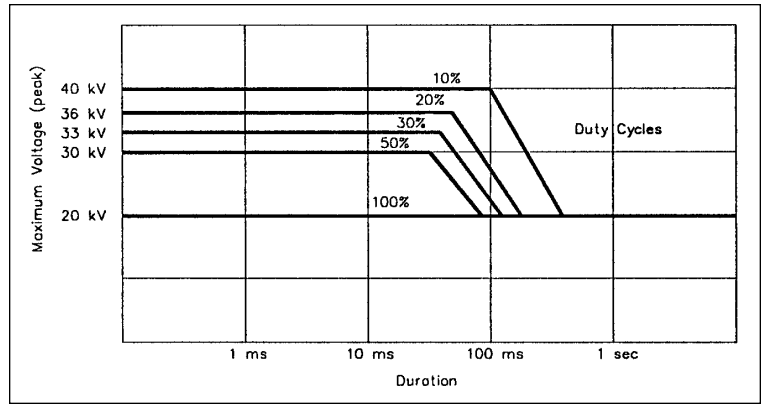

Figure 2. Maximum Peak Pulse Derating.

lead is rated at 1,000 volts and the removable crocodile clip opens up to about one inch (20 mm). The shielded banana plug on the ground lead is compatible with all standard 4 mm banana plug accessories.

High-voltage Measurements

High-voltage measurements are generally of two types: continuous wave (CW) signals and pulses.

CW Measurements. An important consideration in making measurements of high-voltage CW signals is understanding the relationship between signal frequency and the maximum voltage that can be measured. As shown by the Maximum Input

Voltage Derating Curve in Figure 1, the maximum allowable input voltage decreases as frequency increases. The P6015A maximum voltage input is 20 kV (DC + peak AC) from DC to 460 kHz. Beyond 460 kHz, power dissipation in the probe head plastic components increases due to dielectric loss. This effect increases as the frequency increases until the plastic components begin to heat. The heat dissipation limit determines the final rated maximum voltage of approximately 1.5 kV (1.1 kV RMS) at 75 MHz.

Pulse Measurements. The maximum peak pulse is also derated. The Peak Pulse Derating

Curve (Figure 2) shows that the maximum measurable peak pulse is a function of pulse duration and duty cycle. Duty cycle, defined as the ratio of pulse width to signal period, is expressed as a percentage. Figure 2 indicates that the maximum peak voltage of 40 kV is for a pulse with a duration of ≤ 100 ms and a 10% duty cycle.

WARNING

Due to the inherent hazards associated with making high-voltage measurements, this product is intended for use by qualified personnel who have had appropriate training in making these measurements.

P6015A Characteristics

Type – Passive high voltage probe.
Length – 10 Feet and 25 Feet.
Attenuation – 1,000X.
Input Resistance – 100 M Ω .
Input Capacitance – ≤ 3 pF.
Bandwidth – 75 MHz (10 Ft.); 25 MHz (25 Ft.)
Risetime – ≤ 4.67 ns (10 Ft.); ≤ 14 ns (25 Ft.).
Scope Input R – 1 M Ω .

Compensation Range – 7 pF to 49 pF.
Maximum Input Voltage – 20 kV (DC + peak AC) or 40 kV peak pulse (100 ms).

P6015A OPTIONS

Option 1R – 10 foot with readout.
Option 25 – 25 foot without readout.
Option 2R – 25 foot with readout.

WARRANTY

One Year.

Ordering Information

P6015A High-Voltage Probe

Includes: Hook Tip (206-0463-00), Banana Plug Tip (134-0016-00), Crocodile Clip (plugs onto Ground Lead, 344-0461-00), Ground Lead (196-3363-00), Carrying Case (016-1147-00), Instruction Manual (070-8223-03).

RELATED PRODUCTS

P5100 High-Voltage Probe.
P5200 Active Differential Probe.
P5205 Active Differential Probe.
P5210 Active Differential Probe.

For further information, contact Tektronix:

World Wide Web: <http://www.tek.com>; ASEAN Countries (65) 356-3900; Australia & New Zealand 61 (2) 888-7066; Austria, Eastern Europe, & Middle East 43 (1) 7 0177-261; Belgium 32 (2) 725-96-10; Brazil and South America 55 (11) 3741 8360; Canada 1 (800) 661-5625; Denmark 45 (44) 850700; Finland 358 (9) 4783 400; France & North Africa 33 (1) 69 86 81 81; Germany 49 (221) 94 77-0; Hong Kong (852) 2585-6688; India 91 (80) 2275577; Italy 39 (2) 250861; Japan (Sony/Tektronix Corporation) 81 (3) 3448-4611; Mexico, Central America, & Caribbean 52 (5) 666-6333; The Netherlands 31 23 56 95555; Norway 47 (22) 070700; People's Republic of China (86) 10-62351230; Republic of Korea 82 (2) 528-5299; Spain & Portugal 34 (1) 372 6000; Sweden 46 (8) 629 6500; Switzerland 41 (41) 7119192; Taiwan 886 (2) 765-6362; United Kingdom & Eire 44 (1628) 403300; USA 1 (800) 426-2200

From other areas, contact: Tektronix, Inc. Export Sales, P.O. Box 500, M/S 50-255, Beaverton, Oregon 97077-0001, USA (503) 627-1916

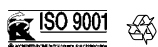

Copyright © 1997, Tektronix, Inc. All rights reserved. Tektronix products are covered by U.S. and foreign patents, issued and pending. Information in this publication supersedes that in all previously published material. Specification and price change privileges reserved. TEKTRONIX and TEK are registered trademarks.