

SPECIFICATIONS

Description

The P6103 probe is a miniature, 10X passive probe for use with DC to 50 MHz oscilloscopes which have a 25 pF nominal input capacitance. It is fully compatible with the Tektronix family of miniature probe accessories. The P6103 is available with 1.0, 2.0, or 3.0-meter cables.

Electrical Characteristics

Attenuation: 10X \pm 1.0% at dc. (Probe installed on 2225 Series oscilloscope.)

Input Resistance (System): 10 M Ω \pm 0.5%. See Figure 1.

Input Capacitance: (See Figure 1.): 1.0-meter probe: \approx 10.9 pF.
2.0-meter probe: \approx 13.2 pF.
3.0-meter probe: \approx 15.5 pF.

Compensation Range: 1.0-meter probe: 15 pF to 35 pF.
2.0-meter probe: 15 pF to 35 pF.
3.0-meter probe: 15 pF to 30 pF.

High-frequency compensation is optimized for use on oscilloscopes which have a nominal input capacitance of 25 pF. When using the probe on oscilloscopes with input C at the extremes of the P6103's specified compensation range, readjustment of the h-f compensation circuitry may be necessary. Adjustment will provide adequate response at low frequencies (< 1 MHz), but there may be increased aberrations and/or decreased bandwidth response at higher frequencies.

System Bandwidth (-3 dB):

Use of the P6103 probe on any oscilloscope with a bandwidth measured to be greater than 50 MHz from a properly terminated 50- Ω source, and having an input capacitance of 25 pF \pm 2 pF, will result in a system bandwidth of at least 50 MHz. A similar correspondence is achieved for all oscilloscopes of lower bandwidth and identical capacitance range.

Maximum Non-Destructive Input Voltage:

500 V (dc + peak ac) to 1.3 MHz. See Figure 2 for voltage curve.

Environmental Characteristics

Temperature Range (Operating): -15° C to + 75° C (+ 5° F to + 167° F).

Temperature Range (Nonoperating): - 62° C to + 85° C (- 80° F to + 185° F).

Humidity: Five cycles (120 hr) at 95% to 97% relative humidity. Per Tek Standard 062-2847-00, Class 3. Ref MIL-E-16400F, paragraph 4.5.9.5.1, class 4.

Physical Characteristics

Probe Cable Length and Net Weight (Includes Accessories):

1.0-meter probe: (3.3 ft): 78 g (2.74 oz).
2.0-meter probe: (6.6 ft): 102 g (3.62 oz).
3.0-meter probe: (9.9 ft): 125 g (4.40 oz).

Safety

To avoid explosion, do not operate product in an explosive atmosphere unless it has been specifically certified for such operation

This product meets the requirements of UL 1244.

NOTE

Always position the adjustment cover in the detent position over the adjustment opening.

First Printing August 1986

Revised MAY 1989

Copyright © 1986, Tektronix, Inc. All rights reserved.

INSTRUCTION SHEET
WITH PARTS HISTORY
NO. 070-6156-01
PRODUCT GROUP 60

TEK PROBE
AND ACCESSORIES

P6103

10X PASSIVE PROBE

Tektronix[®]
COMMITTED TO EXCELLENCE

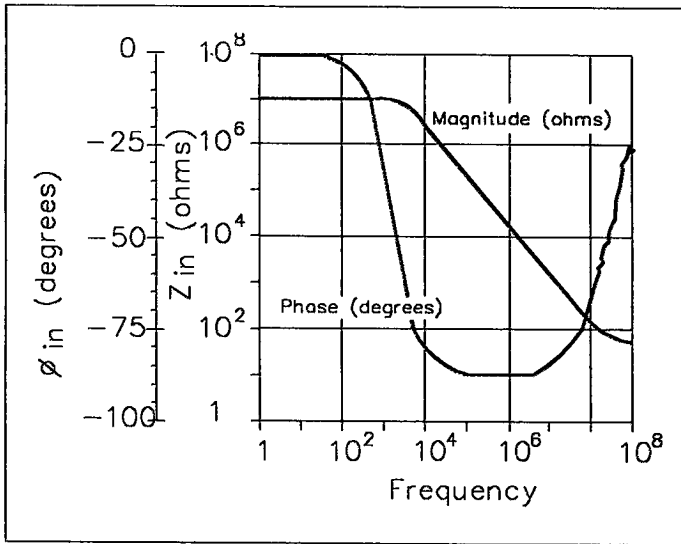

Figure 1. Typical input impedance.

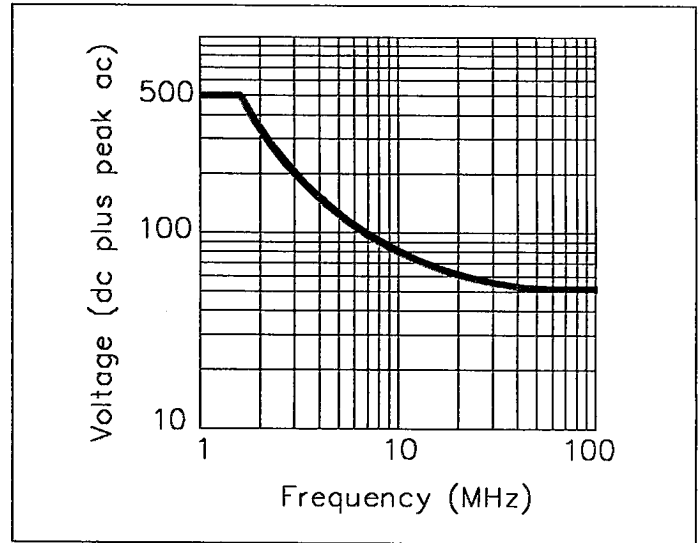

Figure 2. Typical derating versus frequency.

OPERATING CONSIDERATIONS

Probe Low-Frequency Compensation.

Due to variations in oscilloscope input characteristics, probe low-frequency compensation may need adjustment after moving the probe from one input to another. To adjust probe l-f compensation, apply the probe tip to a square-wave signal of 1 kHz (such as an oscilloscope calibrator output). Rotate the sleeve on the probe head to expose the compensating adjustment. Using a low-reactance alignment tool, adjust the compensation capacitor to obtain the squarest

waveform front corner.

Probe Grounding.

Inductance introduced by a long signal lead or ground lead will form a resonant circuit that will ring and distort the true waveform if driven by a signal containing significant frequency components at or above resonance. The ground lead and signal input-connections should be as short as possible to maintain the best waveform fidelity.

Maintenance

WARNING

The following servicing instructions are for use by qualified personnel only. To avoid electrical shock, do not perform probe maintenance while the probe is connected to a signal source.

Probe Compensation Procedures

To adjust probe l-f compensation, apply the probe tip to a square-wave signal of 1 kHz (such as an oscilloscope calibrator output). Rotate the sleeve on the probe head to expose the compensating adjustment (see Figure 3). Using a low-reactance alignment tool, adjust the the compensation capacitor to obtain the squarest waveform front corner.

High-frequency compensation seldom requires adjustment. However, if the probe has excessive h-f aberrations or insufficient bandwidth or is to be used on an oscilloscope with

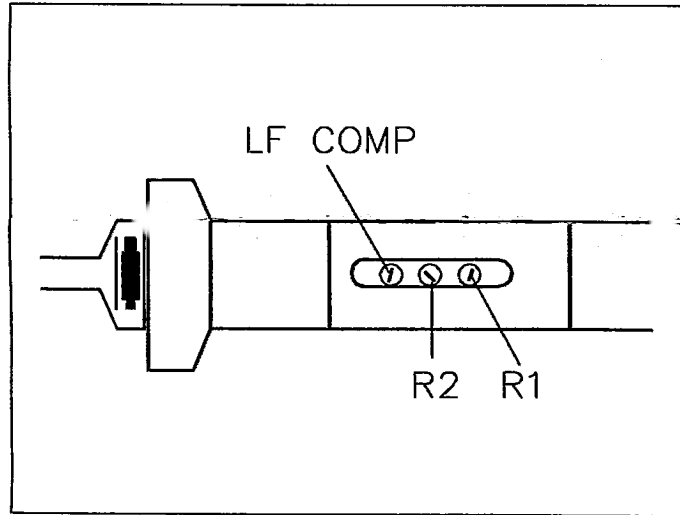

Figure 3. Compensation adjustment locations.

a nominal input capacitance at the extremes of the specified compensation range, h-f adjustments can be made with R1 and R2. Remove the adjustment-opening cover by carefully spreading the cover apart and pushing it toward the rear of the probe body until the opening is uncovered. A 100 kHz, fast rise (<1 ns) square-wave generator terminated into a 50-Ω load should be used. Connection can be made to this source with a BNC-to-miniature probe tip adapter (Tek Part No. 013-0084-00). The resulting oscilloscope display should be adjusted for the best rise time and flattest response in the first ≈30 ns (see Figure 4 for further information).

Always move the adjustment cover to the detent position over the adjustment opening when adjustments have been completed.

Cleaning

Accumulated dirt can be removed with a soft cloth dampened with a nonresidue type cleaner, preferably isopropyl alcohol. Before using any other type of cleaner, consult you Tektronix Service Center or representative. In particular, avoid benzine, toluene, xylene, acetone, MEK, or other solvents.

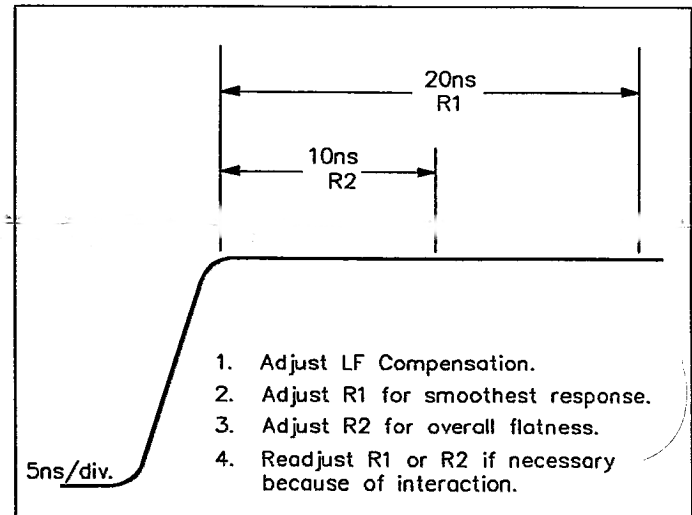

Figure 4. High-frequency typical adjustment procedure.

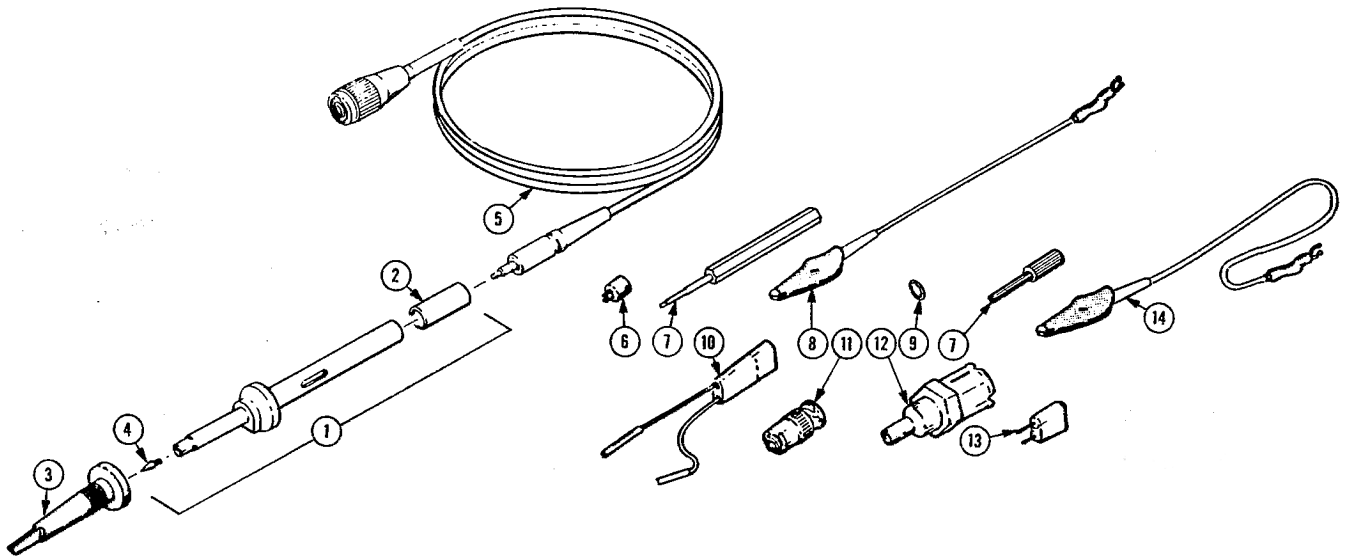

Fig. & Index No.

Fig. & Index No.	Tektronix Part No.	Serial/Assembly No. Effective	Dscont	Qty	12345 Name & Description	Mfr. Code	Mfr. Part No.
5-1	206-0361-00	8735		1	PROBE HEAD ASSY:2.0 METER (STANDARD ONLY)	80009	206-0361-00
	206-0361-01	8736	8851	1	PROBE HEAD ASSY:2.0 METER (STANDARD ONLY)	80009	206-0361-01
	206-0361-03	8901		1	PROBE HEAD ASSY:2.0 METER (STANDARD ONLY)	80009	206-0361-03
	206-0365-00	8735		1	PROBE HEAD ASSY:1.0 METER (OPTION 01 ONLY)	80009	206-0365-00
	206-0365-01	8736	8851	1	PROBE HEAD ASSY:1.0 METER (OPTION 01 ONLY)	80009	206-0365-01
	206-0365-03	8901		1	PROBE HEAD ASSY:1.0 METER (OPTION 01 ONLY)	80009	206-0365-03
	206-0367-00	8735		1	PROBE HEAD ASSY:3.0 METER (OPTION 03 ONLY)	80009	206-0367-00
	206-0367-01	8736	8851	1	PROBE HEAD ASSY:3.0 METER (OPTION 03 ONLY)	80009	206-0367-01
	206-0367-02	8901		1	PROBE HEAD ASSY:3.0 METER (OPTION 03 ONLY)	80009	206-0367-02
-2	200-3342-00			1	.COVER,ACCESS:PROBE COMP	80009	200-3342-00
-3	013-0107-05	8742		1	.TIP,PROBE:RETRACTABLE HOOK ASSY	80009	013-0107-05
	013-0107-06	8743		1	.TIP,PROBE:MINIATURE/COMPACT SIZE	80009	013-0107-06
-4	131-3723-00	8735		1	.CONTACT,ELEC:SIGNAL,SST	80009	131-3723-00
	-----	8736	8851	1	.CONTACT,TIP:SIGNAL,CU BE (SEE OPTIONAL ACCESSORIES)		
-5	174-0395-00			1	CABLE ASSY,RF:50 OHM COAX,2.0M,SMOKETAN	80009	174-0395-00
	174-0394-00			1	CABLE ASSY,RF:83 OHM COAX,1.0 METER,BLACK (OPTION 01 ONLY)	80009	174-0394-00
	174-0396-00			1	CABLE ASSY,RF:39 OHM COAX,3.0M,SLATEGRAY (OPTION 03 ONLY)	80009	174-0396-00
STANDARD ACCESSORIES							
-6	-----			1	TIP,PROBE:IC TEST (SEE OPTIONAL ACCESSORIES)		
-7	003-1364-01	8844		1	SCREWDRIVER:ADJUSTABLE TOOL,PLASTIC TIP	80009	003-1364-01
	003-1433-00	8845		1	SCREWDRIVER:ADJUSTMENT TOOL,METAL TIP	80009	003-1433-00
-8	196-3120-00			1	LEAD,ELECTRICAL:23 AWG,5.0 L,GROUND	80009	196-3120-00
-9	-----			2	BAND,MARKER:0.371 DIA,WHITE,PLASTIC		
	-----			2	BAND,MARKER:0.371 DIA,YELLOW,PLASTIC		
	-----			2	BAND,MARKER:0.371 DIA,RED,PLASTIC		
	-----			2	BAND,MARKER:0.371 DIA,GREEN,PLASTIC (REPLACEABLE AS A KIT OF 9 COLORS) (SEE OPTIONAL ACCESSORIES)		
	131-3723-00	8735		1	CONTACT,ELEC:SIGNAL,SST	80009	131-3723-00
	-----	8736	8851	1	TIP ASSY,PROBE:2 METER (SEE OPTIONAL ACCESSORIES)		
	070-6156-01			1	SHEET,TECHNICAL:INSTR,P6103	80009	070-6156-01

Replaceable Parts - P6103

OPTIONAL ACCESSORIES

-10	015-0325-00		1	ADAPTER, PROBE: PROBE TO CONNECTOR PINS	80009	015-0325-00
-11	013-0084-01		1	ADAPTER, CONN: BNC TO PROBE	24931	28P156-1
-12	017-0088-00		1	CONN, PLUG, ELEC: 50 OHM, GR	80009	017-0088-00
-13	013-0085-00		1	TIP, PROBE: GROUNDING	80009	013-0085-00
-14	196-3121-00		1	LEAD, ELECTRICAL: 23 AWG, 12.0 L	80009	196-3121-00
	015-0201-07		1	TIP, PROBE: IC TEST, PKG OF 10	80009	015-0201-07
	015-0201-08		1	TIP, PROBE: IC TEST, PKG OF 100	80009	015-0201-08
	016-0633-00		1	MARKER SET, CA: 2 EA VARIOUS COLORS	80009	016-0633-00
	131-3723-01	8851	1	CONTACT, ELEC: SIGNAL, SST	80009	131-3723-01
	131-3723-03	8901	1	CONTACT, TIP: SIGNAL, CU BE	80009	131-3723-03
	003-1433-01	8845	1	SCREWDRIVER: ADJUSTMENT TOOL, PKG OF 5	80009	003-1433-01

CROSS INDEX - MFR. CODE NUMBER TO MANUFACTURER

Mfr. Code	Manufacturer	Address	City, State, Zip Code
24931	SPECIALTY CONNECTOR CO INC	2100 EARLYWOOD DR PO BOX 547	FRANKLIN IN 46131
80009	TEKTRONIX INC	14150 SW KARL BRAUN DR PO BOX 500	BEAVERTON OR 97707-0001