

Tektronix[®]
COMMITTED TO EXCELLENCE

Instructions

P6120 PASSIVE PROBE

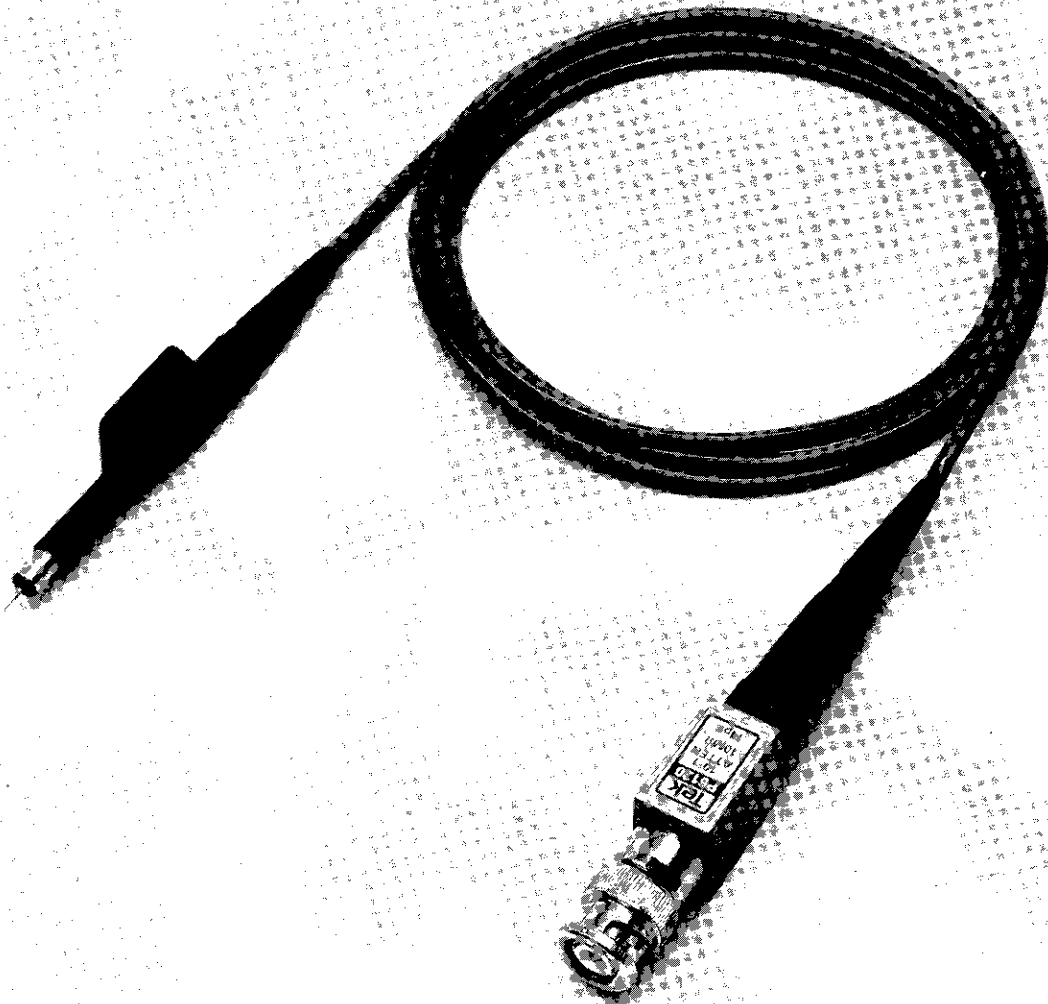

3392-01

010 6120 01

SPECIFICATION

INTRODUCTION

The TEKTRONIX P6120 is a miniature, 10X passive probe designed for use with dc to 60 MHz oscilloscopes having an input capacitance range of 23 to 51 pF (1.5 Meter length) and an input resistance of 1 M Ω . The compensating box houses an adjustable network that provides optimum transient response when the probe is used with oscilloscopes having bandwidths up to 60 MHz.

ACCESSORIES

Standard accessories for the P6120 include this instruction manual, an accessory pouch, a ground lead, a retractable hook tip, an insulating sleeve, and two marker bands. Use of accessories is described later in this manual.

PERFORMANCE CONDITIONS

The electrical characteristics listed in Table 1 are valid for a compensated probe used with a calibrated oscilloscope system and operated within the environmental conditions stated in Table 2. The oscilloscope must be operating in an ambient temperature between +20°C and +30°C (+68°F to +86°F). Physical characteristics for the P6120 Probe are listed in Table 3.

Items listed in the "Performance Requirement" column are verifiable qualitative or quantitative limits. Items listed in the "Supplemental Information" column are not verified in this manual; they are either explanatory notes, performance characteristics for which no absolute limits are specified, or characteristics that are impractical to check.

Table 1
Electrical Characteristics

Characteristics	Performance Requirements	Supplemental Information
Attenuation (System)	10X \pm 3% at dc (oscilloscope input resistance must be 1 M Ω \pm 2% at dc).	
Input Resistance (Probe)	Series resistor—9.0 M Ω \pm 1%.	With compensation box shorted; resistance across probe tip 8.91 M Ω to 9.09 M Ω .
Input Resistance (System)	10 M Ω \pm 2%. ^a	See Figure 1 for input resistance (R_p) and input capacitance (X_p) graph.
Input Capacitance	Approximately 14 pF.(1.5 Meter) ^a Approximately 17 pF.(3.0 Meter) ^a	
Compensation Range	23 pF to 51 pF(1.5 Meter) ^a 23 pF to 47 pF(3.0 Meter) ^a	
Bandwidth (–3 dB)	Dc to 60 MHz.(1.5 meter) Dc to 50 MHz.(3.0 meter)	Measured on TEKTRONIX 2213 or equivalent; 60 MHz oscilloscope with 30 pF input and 82 Ω damping resistance.
Rise Time	<5.9 ns.(1.5 Meter) <7.0 ns (3.0 Meter)	Calculated from bandwidth.
Aberrations		+3%, –3%, 5% p-p in addition to oscilloscope aberrations.
Maximum Nondestructive Input Voltages		
Ac or Dc Coupled	500 V (dc + peak ac) to 3 MHz derated to 70 V (dc + peak ac) at 50 MHz.	See Figure 2 for derating curve.

^aPerformance Requirement not checked in manual.

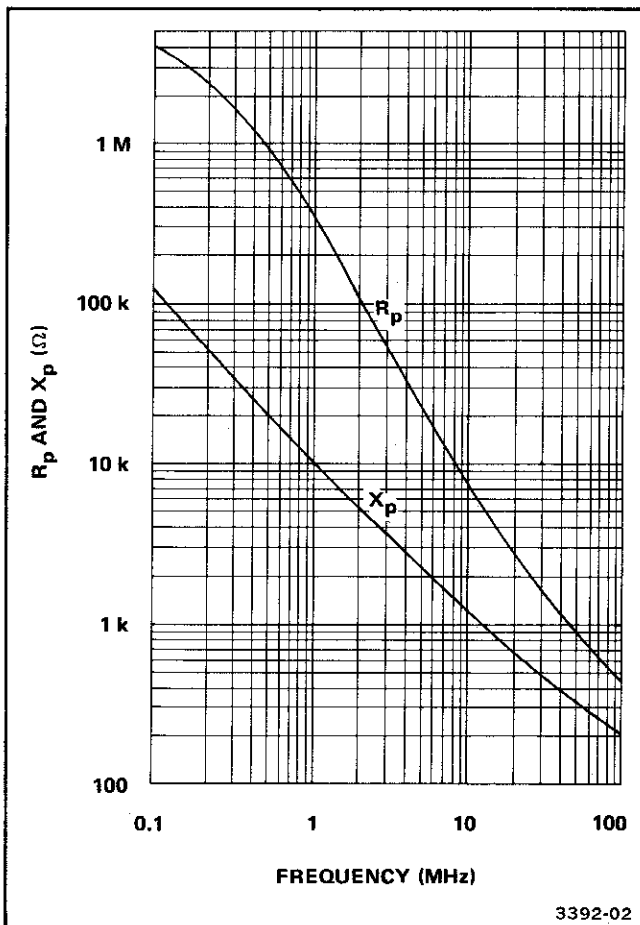

Figure 1. Typical Rp and Xp versus frequency curves.

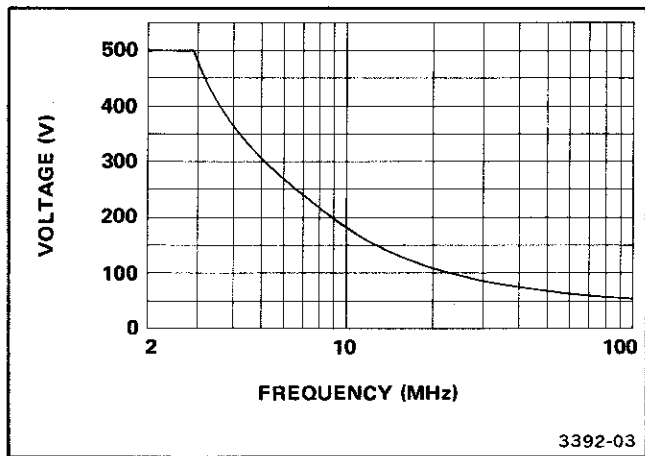

Figure 2. Typical voltage derating with frequency curve.

Table 2
Environmental Characteristics

Characteristics	Description
Temperature Range	
Operating	-15° to +75°C (+5° to +167°F).
Nonoperating	-62° to +75°C (-80° to +167°F).
Altitude	
Operating	To 4,500 m (15,000 ft).
Nonoperating	To 15,000 m (50,000 ft).
Humidity	
Nonoperating	Five cycles (120 hours) at 95% to 97% relative humidity.
Shock	
Nonoperating	To 500 g's, 1/2 sine; 1/2 ms, 1 ms, duration 18 shocks, 3 axes.
Transportation	Qualifies under National Safe Transit Test Procedure 1A, 48-inch drop.

Table 3
Physical Characteristics

Characteristics	Description
Net Weight (Including Accessories)	
1.5 Meter Probe	3 oz(85 g)
3.0 Meter Probe	4.3 oz(122 g)

OPERATING CONSIDERATIONS

PROBE HANDLING

The P6120 Probe and its accessories should be handled carefully at all times to avoid damage. The following precautions are recommended:

1. Avoid dropping the probe head, since damage to the probe tip may occur.
2. Treat the probe tip with care. When not in use, protect the probe tip by covering it with the retractable hook tip.
3. Exercise care to prevent crushing the cable or placing excessive strain on it by pulling.

PROBE GROUNDING

A passive probe is a capacitive divider for high-frequency signal components. Inductance introduced by either a long signal lead or ground lead will form a series-resonant circuit that will ring if driven by a signal containing significant frequency components at or above circuit resonance. These oscillations (ringing) can appear on the oscilloscope display

and distort the true waveform. The ground lead and probe signal input connections should be kept as short as possible to maintain the best waveform fidelity.

PROBE ACCESSORIES

The standard accessories for the P6120 Probe are listed under "Accessories" in the "Replaceable Parts List" at the back of this instruction manual and are described in the following paragraphs. These accessories are supplied to aid in connecting the probe to circuitry under test and to protect the probe against damage (see Figure 3).

Ground Lead

Proper grounding will minimize the chance of ringing on the oscilloscope display. The 250-mm ground lead has a miniature alligator clip at one end for attaching the probe to the oscilloscope ground. Attached to the other end is a metal tip which should be carefully inserted into the connector receptacle on the probe head.

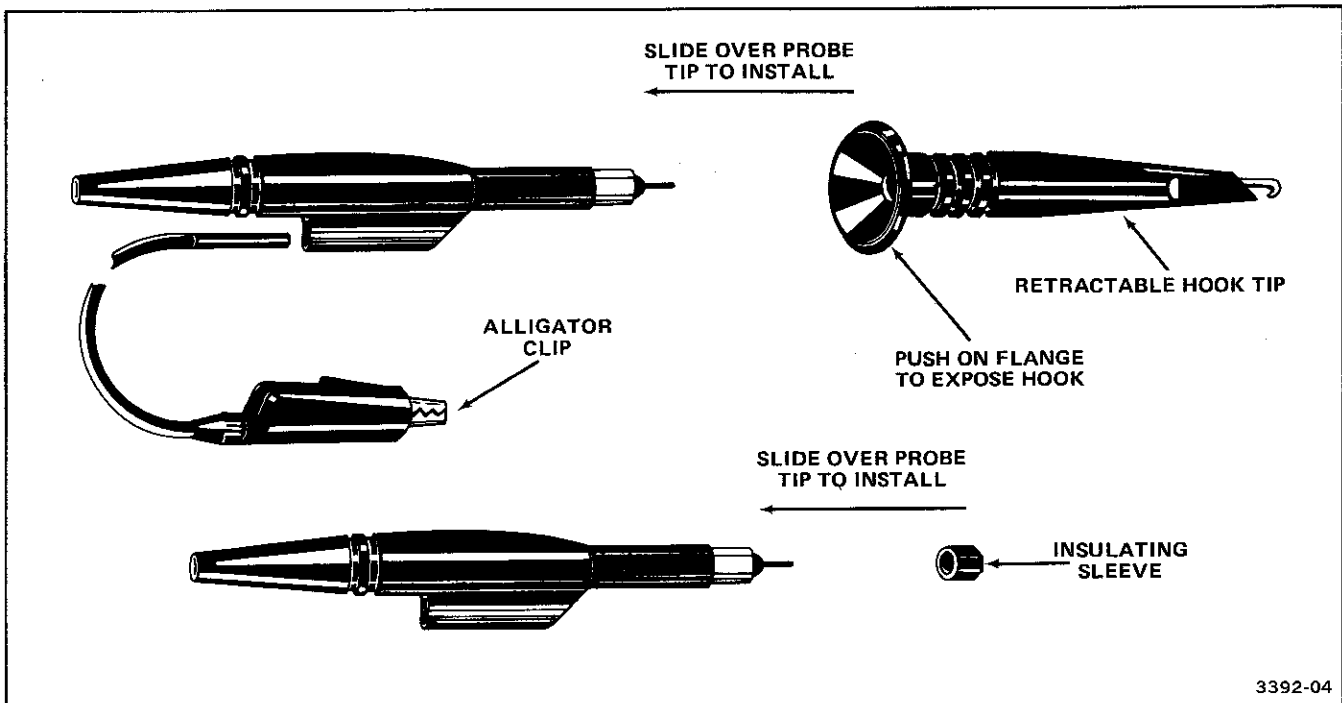

Figure 3. Probe accessories.

Insulating Sleeve

The small tubular insulating sleeve supplied with the probe should be placed over the metal sleeve of the probe tip when using the ground lead. Use of this sleeve will prevent inadvertent grounding of the circuitry under test. The sleeve should be removed when using the retractable hook tip.

Retractable Hook Tip

The retractable hook tip provides a hands-free connection to a test point or component lead so that other adjustments or functions may be accomplished.

NOTE

Tektronix manufactures several different hook tips. Be sure to use the hook tip specified in this manual's parts list. Other retractable hook tips may not seat properly.

This tip is attached to the probe by sliding it over the probe tip. To expose the tip end for connections, hold the probe head near its ground lead jack. Pull the hook tip's flange toward the ground jack. The spring inside the tip will hold the connection together when the flange is released.

Optional Accessory

Tip, Probe with Actuator. Part No. 013-0191-00. Specifically designed for use in constricted environments I.E. designing and troubleshooting DIP circuitry.

PROBE COMPENSATION

Due to slight variations in oscilloscope input capacitance, it is usually necessary to compensate the probe whenever it has been transferred for use from one instrument to another or from one channel to another on the same oscilloscope.

Probe Compensation Adjustment

To compensate the probe, use the following procedure and the equipment referenced from Table 4.

Equipment Required (See Table 4)
Oscilloscope System (Item 1)
Square-Wave Generator (Item 2) ^a
Adapter (Item 5) ^a
Low-Capacitance Adjustment Tool (Item 6)

^aNot required if oscilloscope has a calibrator output.

**Table 4
Test Equipment Required**

Item and Description	Minimum Specification	Use	Examples of Applicable Equipment
1. Oscilloscope System	Bandwidth: 60 MHz or greater. Deflection factor: 20 mV/div (0.2 V/div with probe).	Probe compensation adjustment and bandwidth check.	TEKTRONIX 2213 Oscilloscope.
2. Square-Wave Generator ^a	Square-wave frequency: 1 kHz. Amplitude: 1.0 V into 1 MΩ.	Probe compensation adjustment.	TEKTRONIX PG 506 Calibration Generator.
3. Leveled Sine-Wave Generator	Amplitude: adjustable from 0 V to 1.0 V. Frequency: variable to at least 60 MHz plus fixed 50-kHz reference.	Bandwidth check.	TEKTRONIX SG 503 Leveled Sine-Wave Generator.
4. Ohmmeter	Accuracy: 0.11% of resistance reading.	Attenuation check.	Hewlett-Packard 3465B.
5. Adapter	Probe-tip-to-bnc male.	Probe compensation adjustment ^a . Bandwidth check.	TEKTRONIX Part Number 013-0084-01.
6. Low-Capacitance Adjustment Tool	Bit size: 1/16 inch.	Probe compensation adjustment.	TEKTRONIX Part Number 003-0675-01.

^aNot required if oscilloscope has a calibrator output.

1. Set the oscilloscope controls as follows:

Volts/Div	20 mV
Sec/Div	1 ms
Bandwidth	Full
Input Coupling	DC

2. Attach the probe bnc connector to the oscilloscope vertical-channel input.

3. Connect the probe tip to the oscilloscope calibration signal output. If the oscilloscope does not have a calibration output, a calibration generator may be used as follows:

- a. Set the square-wave generator for an output of 1.0 V. The signal output should be a square wave at approximately 1 kHz.
- b. Connect the probe tip to the generator output via a probe-tip-to-bnc adapter.

4. Set the oscilloscope triggering controls for a stable, triggered display. The display should be approximately 10 square-wave cycles with an amplitude of 5 divisions. Center the display on the screen.

5. ADJUST—Probe Low-Frequency Compensation control for the best flat top display on the waveforms by using a low-capacitance adjustment tool (see Figure 4). Typical oscilloscope waveform displays for the range of the Compensation control are shown in Figure 5, with the correct setting shown in the middle illustration.

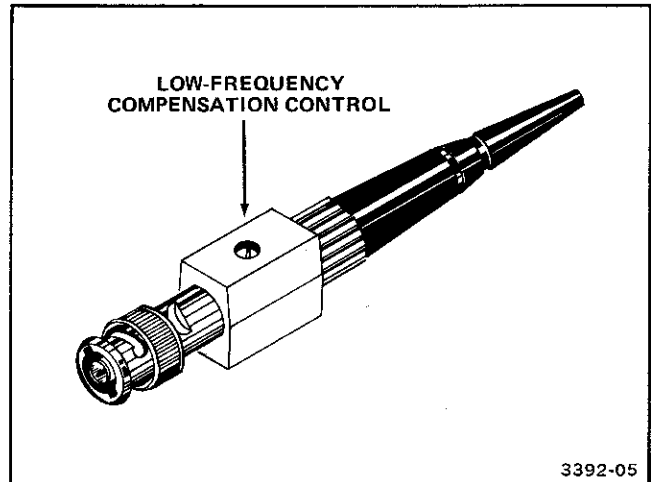

Figure 4. Low frequency adjustment location.

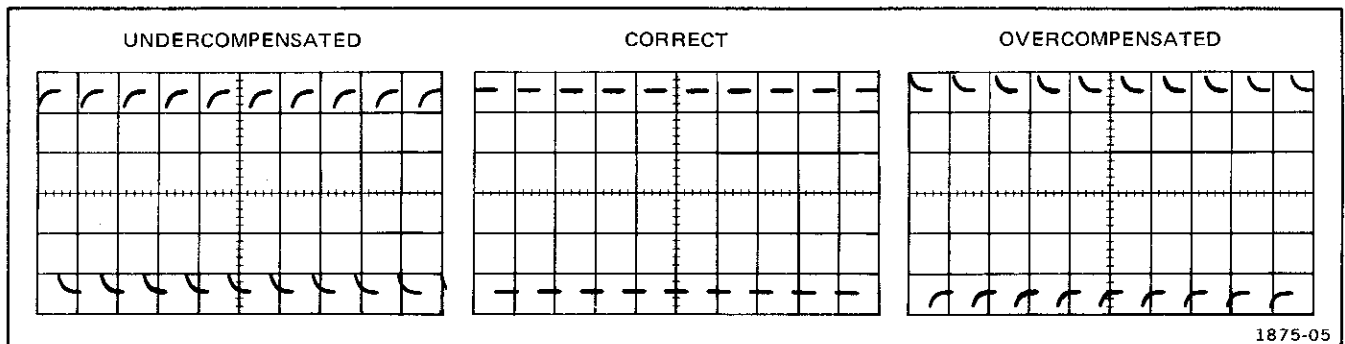

Fig. 5. Probe compensation display.

Figure 5. Probe low frequency compensation.

PERFORMANCE CHECK

This part describes procedures for verifying the probe's bandwidth, rise time, and attenuation accuracy.

TEST EQUIPMENT REQUIRED

The test equipment listed in Table 4, or an equivalent piece of test equipment, is required to accomplish a complete Performance Check. In Table 4, the specifications given for the equipment are the minimum necessary to provide accurate results. Therefore, the equipment used must meet or exceed the listed specifications. Detailed operating instructions for the test equipment are not provided in these procedures. Refer to the appropriate test equipment instruction manual if more operating information is required.

PERFORMANCE CHECK PROCEDURE

1. Bandwidth and Rise Time Checks

Equipment Required (See Table 4)

- Oscilloscope System (Item 1)
- Leveled Sine-Wave Generator (Item 3)
- Adapter (Item 5)

- a. Perform the "Probe Compensation" procedure using the test oscilloscope.
- b. Set the oscilloscope Volts/Div switch to 20mV/Div (0.2V/Div including 10X probe.) and Time/Div to 1 ms.
- c. Connect the probe tip to the leveled sine-wave generator output via a probe-tip-to-bnc adapter.
- d. Set the sine-wave generator frequency-range switch to Ref=0.5 (50 kHz) and set its output amplitude control to produce a 6-division display on the oscilloscope. Then center the display on the crt screen.

- e. Adjust the generator frequency-range switch to the 50- to 100-MHz range and slowly increase the setting of the variable frequency control until the display amplitude decreases to exactly 4.2 divisions (-3 dB).

- f. CHECK—That bandwidth of the probe/oscilloscope system, as indicated by the sine-wave generator frequency readout, is at least 60 MHz.

- g. Once the bandwidth of the system is known, the approximate rise time can be calculated using the formula:

$$\text{Rise Time} \approx \frac{350}{\text{Bandwidth (MHz)}}$$

With a bandwidth of 60 MHz, the rise time is (approximately) 5.9 ns.

2. Probe Attenuation Accuracy Check

Equipment Required (See Table 4)

- Ohmmeter (Item 4)

- a. Connect one lead of the precision ohmmeter to the probe tip and the other lead to the inner conductor of the probe bnc connector.
- b. CHECK—that the meter reading is between 8.91 and 9.09 MΩ.

NOTE

When the meter reading is between 8.91 and 9.09 MΩ and the test oscilloscope has an input resistance accuracy as described in the "Specification" section, the probe attenuation will be within its specified limits.

MAINTENANCE

WARNING

To avoid electrical shock, do not perform any probe maintenance while the probe is connected to a signal or voltage source.

ened in any one of the following recommended cleaning agents: mild detergent and water solution, isopropyl alcohol (Isopropanol), or ethyl alcohol (Fotocol or Ethanol). Do not use abrasive cleaners.

CLEANING

CAUTION

Do not use chemical cleaning agents which might damage the materials used in this probe. In particular, avoid chemicals which contain benzene, toluene, xylene, acetone, or similar solvents. Use only recommended cleaning agents.

Occasional cleaning may be required. Dirt that accumulates on the probe can be removed with a soft cloth damp-

PROBE MODULE REPLACEMENT

If the probe is damaged or fails, replacement modules are available through your local Tektronix Field Office or representative. The "Replaceable Parts List" at the rear of this manual provides the Tektronix part numbers and descriptions for the replacement modules.

Modular construction has been incorporated in the design of the P6120 to simplify repairs. The probe head, compensation box, and cable are available as wired units for replacement. To remove the probe head, pull the cable away from the probe head until they are unplugged. To remove the compensation box, first unscrew the retainer cover from the compensation box body. Then pull on the cable until it separates from the compensation box. Individual components within the probe head and the compensation box are not considered replaceable parts. To install new modules, reverse the above procedures.

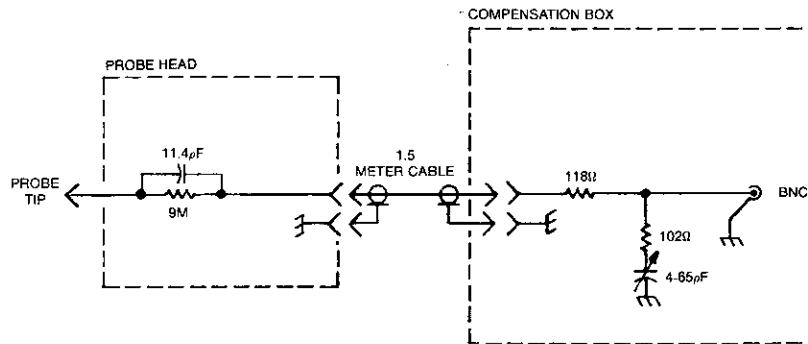

1.5 METER SCHEMATIC DIAGRAM

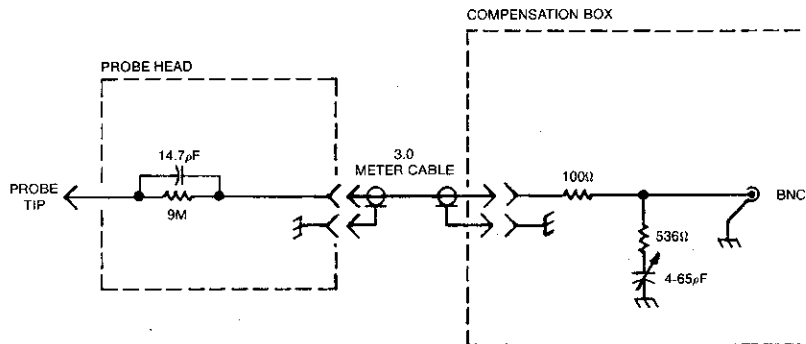

3.0 METER SCHEMATIC DIAGRAM

3392-07A

REPLACEABLE PARTS LIST

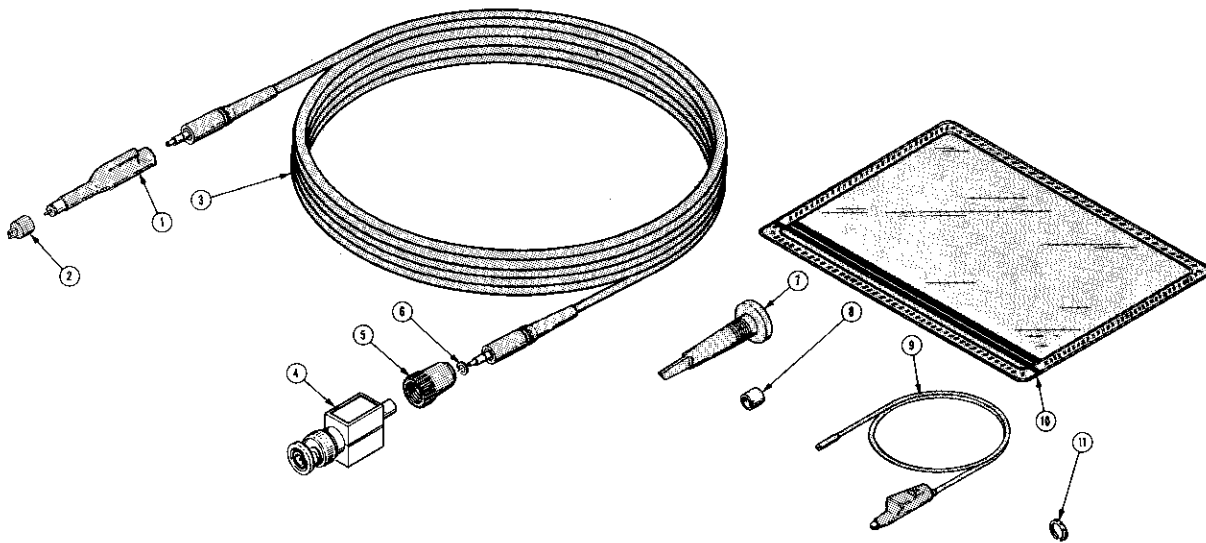

Fig. & Index No.	Tektronix Part No.	Serial/Model No. Eff Dscont	Qty	1	2	3	4	5	Name & Description	Mfr Code	Mfr Part Number
------------------	--------------------	-----------------------------	-----	---	---	---	---	---	--------------------	----------	-----------------

1.5 METER PROBE

	010-6120-01		1						PROBE,VOLTAGE:1.5M L,10 X W/ACCESS	80009	010-6120-01
	010-6120-00		1						. PROBE,VOLTAGE:1.5M L,10X	80009	010-6120-00
-1	206-0253-00		1						. TIP PROBE:SLIP-ON	80009	206-0253-00
-2	015-0201-04		1						. TIP PROBE:IC TEST,PKG OF 10	80009	015-0201-04
	015-0201-05		1						. TIP PROBE:IC TEST,PKG OF 100	80009	015-0201-05
-3	175-3217-00		1						. CABLE ASSY,RF:39 OHM PER FOOT COAX,1.5M L	80009	175-3217-00
-4	206-0274-00		1						. COMP BOX:1.5 METER	80009	206-0274-00
-5	200-2547-00		1						. COVER,CABLE NIP:	80009	200-2547-00
-6	210-1377-00		1						. WASHER,SPRTNSN:0.16 ID X 0.01 THK,STL,0.22 OD	86928	A367-324

3 METER PROBE

	010-6120-05		1						PROBE,VOLTAGE:3M L,W/ACCESSORIES	80009	010-6120-05
	010-6120-04		1						. PROBE,VOLTAGE:3M L	80009	010-6120-04
-1	206-0280-00		1						. TIP,PROBE:SLIP-ON	80009	206-0280-00
-2	015-0201-04		1						. TIP PROBE:IC TEST,PKG OF 10	80009	015-0201-04
	015-0201-05		1						. TIP PROBE:IC TEST,PKG OF 100	80009	015-0201-05
-3	175-3217-01		1						. CABLE ASSY,RF:39 OHM PER FOOT COAX,3M L	80009	175-3217-01
-4	206-0281-00		1						. COMP BOX:3.0 METER	80009	206-0281-00
-5	200-2547-00		1						. COVER,CABLE NIP:PLASTIC	80009	200-2547-00
-6	210-1377-00		1						. WASHER,SPRTNSN:0.16 ID X 0.01 THK,STL,0.22 OD	86928	A367-324

STANDARD ACCESSORIES

-7	013-0107-04		1						TIP,PROBE:RETRACTABLE HOOK ASSY	80009	013-0107-04
-8	166-0404-01		1						TUBE, INSULATOR:	80009	166-0404-01
-9	195-0950-00		1						LEAD,ELECTRICAL:23 AWG,8.812 L,0-N	80009	195-0950-00
-10	016-0521-00		1						POUCH,ACCESSORY:	05006	0BD
-11	334-2794-02		2						BAND,MARKER:0.371 DIA,SILVER GRAY,PLASTIC	80009	334-2794-02
	070-3392-01		1						SHEET,TECHNICAL:INSTR P6120	80009	070-3392-00

OPTIONAL ACCESSORIES

	013-0191-00		1						TIP PROBE:W/ACTUATOR	80009	013-0191-00
--	-------------	--	---	--	--	--	--	--	----------------------	-------	-------------

CROSS INDEX—MFR. CODE NUMBER TO MANUFACTURER

Mfr. Code	Manufacturer	Address	City, State, Zip
05006	TWENTIETH CENTURY PLASTICS, INC.	415 E WASHINGTON BLVD.	LOS ANGELES, CA 90015
80009	TEKTRONIX, INC.	P O BOX 500	BEAVERTON, OR 97077
86928	SEASTROM MFG. COMPANY, INC.	701 SONORA AVENUE	GLENDALE, CA 91201