



The NOTEBOOK

BOONTON RADIO CORPORATION · BOONTON, NEW JERSEY

SEP 24 1962

APPLICATIONS OF THE SIGNAL GENERATOR POWER AMPLIFIER

CHARLES W. QUINN, *Sales Engineer*

INTRODUCTION

At first glance the application of an RF Power Amplifier appears limited or obvious. While there are obvious uses, there are many applications which are not apparent. It is the purpose of this article to enumerate and discuss both application categories. The specific requirements for the tests to be described are as many and as varied as the systems involved. For this reason, this article will be limited to a general description and/or example of each test. Detailed information on radio receiver tests may be found in References 1 and 2, at the end of the article. Procedures for radio frequency interference (RFI) testing are given in References 3 and 4. Before dealing directly with applications, let us look at the specifications of the Type 230A Signal Generator Power Amplifier (Figure 1) and clarify them where necessary.

SPECIFICATIONS

RADIO FREQUENCY CHARACTERISTICS

RF RANGE

Total Range: 10 to 500 mc

No. Bands: 6

Band Ranges: 10-18.5 mc 65-125 mc
18.5-35 mc 125-250 mc
35-65 mc 250-500 mc

RF Calibration: Increments of approximately 10%, accurate to ±10%

RF OUTPUT

Range: Up to 15 volts*. *Across external 50 ohm load

Range: Up to 15 volts*

*Across external 50 ohm load

Calibration: 0.2 to 3 volts f.s.;
increments of approx 5%
1.0 to 10 volts f.s.;
increments of approx 5%
2.0 to 30 volts f.s.;
increments of approx 5%

Accuracy: ±1.0db of f.s. (10-250mc)
±1.5db of f.s. (250-500mc)

YOU WILL FIND . . .

Applications of the Signal Generator
Power Amplifier 1
Using the FM Stereo Modulator 5
Editor's Note — Q Meter Winner 8



Figure 1. Type 230A Signal Generator Power Amplifier

Leakage: Sufficiently low to permit measurements at 0.1 volts.

RF Bandwidth*: > 700kc (10-150mc)
> 1.4mc (150-500mc)
*Frequency interval between points 3db down from max. response.

RF INPUT

Level: ≤ 0.316 volts* (30db gain) (10-125mc)
≤ 0.446 volts* (27db gain) (125-250mc)
≤ 0.630 volts* (24db gain) (250-500mc)
*for 10 volts output into 50 ohms

Impedance: 50 ohms

AMPLITUDE MODULATION CHARACTERISTICS

AM RANGE: Reproduces modulation of driving signal generator 0-100%*

AM DISTORTION: <10% added to distortion of driving Signal Generators*
*Up to 5 volt max. carrier output for up to 100% AM

FREQUENCY MODULATION CHARACTERISTICS

FM RANGE: Reproduces modulation of driving Signal Generator except as limited by the RF bandwidth.

INCIDENTAL AM: <10%* added to modulation of driving Signal Generator
*At 150kc deviation.

FM DISTORTION: Negligible distortion added to distortion of driving Signal Generator for deviations and modulation frequencies <150kc.

PHYSICAL CHARACTERISTICS

MOUNTING: Cabinet for bench use; by removal of extruded strips suitable for 19-inch rack mounting.

FINISH: Gray wrinkle, engraved panel (other finishes available on special order).

DIMENSIONS: Height — 7-3/16"
Width — 19-1/2"
Depth — 17-11/16"

WEIGHT: Net: 37 lbs.
Gross Export: 75 lbs.
Gross Domestic: 45 lbs.
Legal Export: 43 lbs.

POWER REQUIREMENTS

230-A: 105-125/210-250 volts, 50—60 cps, 150 watts.

SIGNAL SOURCES

Virtually any signal source, within the frequency range of the 230A, may be used. The obvious sources are signal generators such as the BRC 225A general purpose signal generator, the 202 series FM-AM signal generators, and the 211A and 232A Navigation Aid signal generators. Not so obvious, but nevertheless convenient signal sources, are the 260A and 280A Q Meters, the 250A RX Meter, crystal oscillators, etc.

AMPLIFIER, RECEIVER, AND SYSTEM TESTING

Amplifier, receiver, or system testing may take many forms. A few of these tests are:

1. Overload tests.
 2. AGC characteristics.
 3. Skirt selectivity.
 4. Adjacent channel desensitization.
 5. Cross modulation and intermodulation.
 6. Image and IF rejection.
- Connections for tests 1, 2, 3, and 6 are shown in Figure 2.

Overload Tests

Overload tests are made to determine the input level at which the output of



Figure 2. Setup for Receiver Testing

the unit under test departs from a specified characteristic; i.e., linear, log-linear, etc., by a specified tolerance. Overload tests are usually made on circuits with active elements and are not restricted to the conventional superheterodyne receiver. Single frequency and broadband amplifiers are also tested for overload.

The output of the unit under test may be the input signal amplified, or the demodulated output (AM, FM pulse, etc.), or a voltage or current proportional to input, (analog digital, dc, etc.).

AGC Characteristics

AGC (automatic gain control) characteristics are measured or determined by measuring the relationship between RF input voltage and the dc voltage bias developed by the AGC detector. It is often desirable to determine the RF level which will override the AGC and cause blocking and/or distortion. This level is often much higher than 500,000 microvolts in well-designed systems. See Reference 1 for measurement details.

Skirt Selectivity

Skirt selectivity testing of a communications system requires that the performance of the frequency selective circuits be determined at a frequency considerably removed from the desired frequency, or on the "skirts" of the resonance curve, where attenuation is at a very high value. Typical values are 2 to 5 volts for attenuation figures of 80 to 120 db. In this test, one must be ever cautious of the possibility of overload occurring before the desired point on the skirt is reached. In AM systems, an increase in distortion indicates that overloading has taken place and limits the extent of the "skirt" measurement.²

Adjacent Channel Desensitization Test

Most communication centers transmit on many channels simultaneously. Usually, a given receiver will be in contact with signals of less than 100 microvolts in strength, while one or more transmitters in the same room are operating at a frequency only a few channels from the receiver frequency. The receiver must not, therefore, be affected by strong signals in adjacent channels. It is for

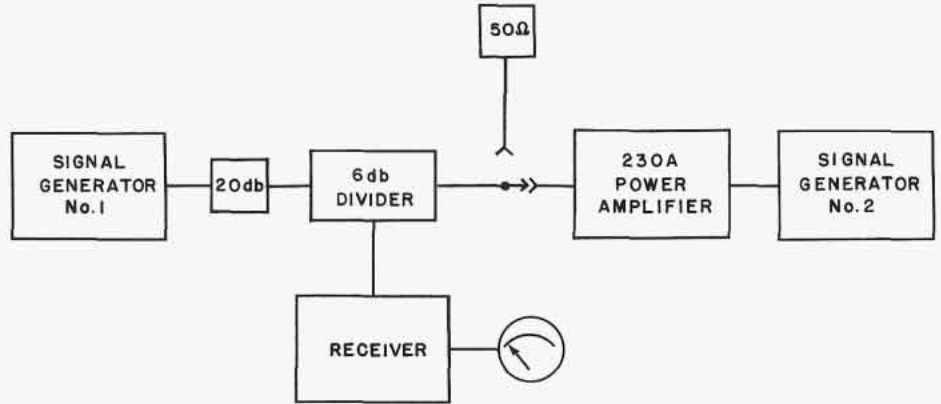

Figure 3. Connections for Desensitization Test

this reason that desensitization characteristics are specified by communication system designers, and that desensitization tests are made.

Desensitization tests are made by connecting the equipment as shown in Figure 3. Signal generator #1 is set to give a convenient metered detector level (sometimes specified for a given system). This is the "desired signal" on channel. Using signal generator #2 in conjunction with the 230A Power Amplifier, the adjacent channel level is raised until the detector level is reduced by a specific amount (usually 3 db). The reading on the 230A voltmeter is twice the voltage required for "desensitization."

Cross Modulation and Intermodulation

Cross modulation and intermodulation tests are made on systems which are inherently very linear. Intermodulation tests are performed by supplying two or more signals to a system and measuring the resultant spurious products. For example, two 15-Mc signals, spaced 1 kc apart, will produce a spectrum (Figure 4) which can be analyzed to determine the amount of intermodulation.

There are two approaches to this test depending upon the amount of intermodulation expected. If the expected intermodulation is greater than 2%, a single 230A amplifier may be used; connected as shown in Figure 5.

Typical intermodulation performance data, taken with the 230A connected as in Figure 5, is given in the table in Figure 6. The test unit was replaced by a 50-ohm termination and measurements were made at 15 Mc.

The data in Figure 6 is indicative of the intermodulation present in the 230A Power Amplifier and expresses its lim-

its for given output levels. Column " V_1/V_2 " shows the value of the rms amplitude of each signal. Column " V_T " shows the meter indication when both signals are applied. The "db" column indicates the level of the highest spurious signal produced. It is the "db" column which is most significant. For instance, a figure of 46 db is typical of a 0.5% product; consequently, system intermodulation products of less than this figure will have little or no significance. Actually, any change in the spurious output detected, when using a passive linear termination, indicates a departure from linearity or phase shift. However, evaluation of absolute value is impractical.

There is another approach to the measurement of small amounts of intermodulation, which, while not tested to date, theoretically should extend this measurement to another order of magnitude. The connections for this technique are shown in Figure 7. (The meter switch is set to the "off" position for this application.)

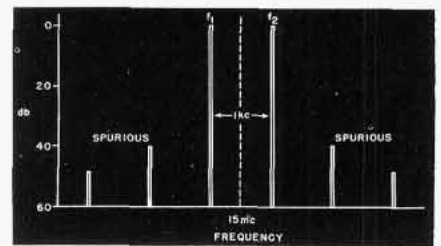

Figure 4. Spectrum for Analyzing Amount of Intermodulation

This system virtually eliminates the intermodulation products present or generated in the driver stages of the 230A Power Amplifier. It also reduces the nonlinear effects of the dynamic plate resistance of the output stage by loading it with considerable linear, passive resistance. It is estimated that a 10 db

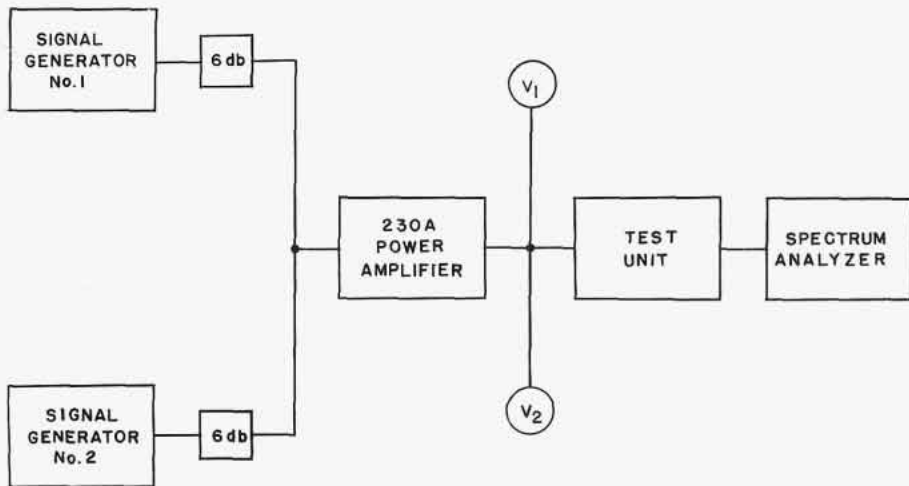

Figure 5. Connections for Checking More than 2% Intermodulation

coupling attenuator will be a good factor for V_1/V_2 values of 1 to 3 volts. Intermodulation of 50 to 60 db should be obtainable using this technique.

For cross modulation tests, two signals are required; connected as shown in Figure 3. Signal generator #1 is set to a prescribed RF level (E_1 and percent modulation) depending upon the system being tested. The demodulated output is noted. Signal generator #2 and the 230A Power Amplifier are then connected and set on an adjacent channel in accordance with the specific test to be made. Signal generator #2 is modulated in the same manner as signal generator #1, which is now set for CW or unmodulated operation. The output (E_2) from the 230A is increased until the demodulated output equals that noted previously.

The cross modulation performance may then be calculated as follows: $C_m = 20 \log E_2/E_1$.

It should be observed that the demodulated output falls off when E_1 only is removed.

Image and IF Rejection Tests

Using the 230A Power Amplifier, IF rejection tests are made on receivers where this rejection is extremely high (in the order of 100 db or more). The image frequency (F_1) is that frequency which is twice the intermediate frequency (IF) away from the desired signal frequency (F_0), in the same direction as the local oscillator (F_{10}). See Figure 8.

IF rejection is made at the intermediate frequency by driving into the receiver front end. This attenuation level is

V_1/V_2	V_T	db
1 v	1.7 v	-48
2 v	3.5 v	-46
3 v	5.6 v	-33
5 v	8.7 v	-24
7 v	11.6 v	-22

Figure 6. Typical Intermodulation Present in Type 230A

usually much higher than image rejection; so that even less sophisticated receivers may require use of the 230A Power Amplifier.

In AM systems, an increase in distortion indicates that overloading has taken place.

RF Wattmeter Calibration

RF wattmeter calibration is accomplished by using a standard signal generator in conjunction with the 230A Power Amplifier as a power source.

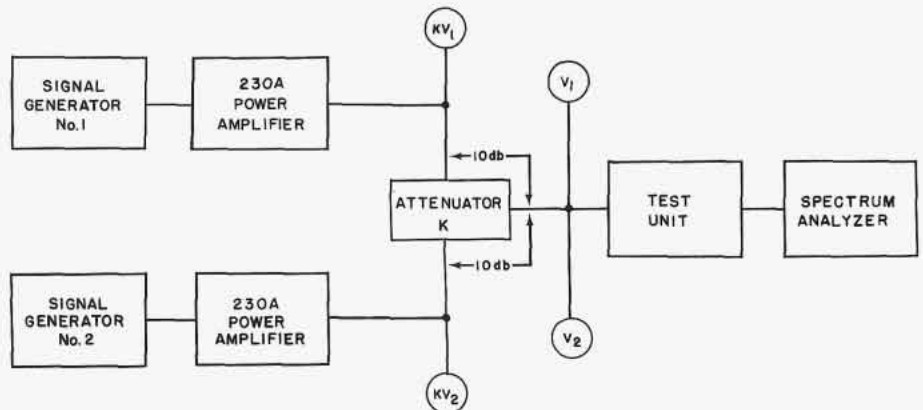

Figure 7. Connections for Checking Small Amounts of Intermodulation

THE BRC NOTEBOOK is published four times a year by the Boonton Radio Corporation. It is mailed free of charge to scientists, engineers and other interested persons in the communications and electronics fields. The contents may be reprinted only with written permission from the editor. Your comments and suggestions are welcome, and should be addressed to: Editor, THE BRC NOTEBOOK, Boonton Radio Corporation, Boonton, N. J.

Power is then connected to the standard wattmeter, and then to the wattmeter to be calibrated. Power up to 9 watts is available for short periods for this application. Higher than specified input levels are necessary, however.

RF Voltmeter Calibration

The procedure for RF voltmeter calibration is somewhat different than for wattmeter calibration, since the voltmeter is usually a relatively high impedance device. The National Bureau of Standards has developed an A-T (Attenuator-Thermocouple) type standard RF voltmeter which may be used for this application. This instrument is a standard for RF voltages from 1 to 300 volts at 10 to 1000 Mc. The output voltage of the 230A amplifier is a function of loading and can be increased many fold over the 50-ohm value. Experiments to date, using line stretchers, stub tuners, and resonant transformers, indicate that voltages from 60 to 100 volts may be developed for voltmeter calibration and other applications requiring large signal levels.

COMPONENT TESTING

Component testing usually takes the form of a breakdown or parameter change which can be checked after sub-

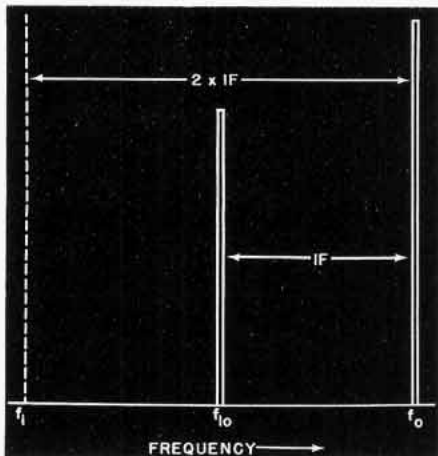

Figure 8. Image Frequency

jecting the component to higher voltage or power stresses than are normally encountered in standard tests. Chokes, resistors, and capacitors are examples of such passive components. For example, in an actual test, a small $7.5\mu\text{h}$ choke subjected to 100 volts RF at 20 Mc, exhibited no change in Q or L after testing. It would be safe to conclude, therefore, that these chokes could be used up to this level. This application could also be extended to active components.

Diode rectification efficiency can be determined with the setup shown in Figure 9. The gain of power transistor circuits can be determined in a similar fashion, since the voltages are measurable with existing RF voltmeters. Circuits requiring high voltages; such as discriminators, limiters, power amplifiers, etc., may be supplied by the 230A. This is sometimes called "down-stage" testing.

HIGH LEVEL DRIVER

As a high level driver, the 230A can be used to power bridges and slotted lines to improve the resolution and accuracy of these measurements. Computers that require high level signals sources for synchronizing purposes at moderately high frequencies may also be driven by the 230A Power Amplifier.

ANTENNA TESTING

The 230A is capable of supplying moderate power for antenna measurements, while, at the same time, providing relatively small leakage from the Power Amplifier itself. This feature permits two antennas to be closer together, thereby shortening the range required.

ATTENUATION MEASUREMENTS

Using the 230A Power Amplifier and an RF millivolt meter, attenuation measurements can be made in the order of 80 db. The 230A provides an additional 28 to 40 db of gain or signal level (assuming the circuit being measured will permit the high voltage) to add to the existing measuring system in the field of attenuation measurements. Filters, long transmission lines, etc., can be tested in this manner.

LOW LEVEL AMPLIFIER

As a low level amplifier, the 230A can be used to amplify small signals, such as a crystal spectrum at a given frequency, for frequency drift measurements.

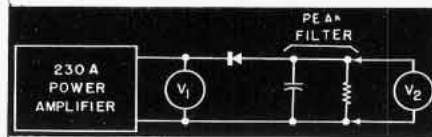

Figure 9. Connections for Checking Diode Rectification Efficiency

FREQUENCY MULTIPLYING

A number of approaches to this application are possible. First, it is possible to amplify the harmonics present in the input signal. The output under these conditions is in the order of 0.2 to 0.5 volts, with 0.2 volts of fundamental input. Another approach is to use a semiconductor harmonic generator to augment the harmonics present in the input signal. This technique yields several volts output, depending upon the input levels available. If sufficient input is available, the 230A input stage may be overdriven and the attendant distortion will produce higher harmonic levels. Approximately 1 to 2 volts may be expected for inputs of the order of 1 volt. Crystal frequency synthesizer output may be multiplied as many as ten times, extending the usefulness of these units to the UHF range.

RADIO INTERFERENCE TESTING

Other applications of the 230A Power Amplifier are found in the Radio Frequency Interference (RFI) field of measurements.

Screen Room Testing

Screen rooms are used to reduce RFI in cases where equipment being tested, or operated, is capable of causing RFI, or is sensitive to RFI. The screen room, in either case, must provide a prescribed

amount of attenuation; usually in the order of 100 db or more.

A method for testing screen rooms is described in Military Specification, MIL-E-4957-A (ASG). This method has become general practice. The specification includes a test at 400 Mc; a frequency that has proved to be rather critical, regardless of room size.

In general, the procedure for making this 400 Mc test is as follows (Figure 10). First, a clear channel at approximately 400 Mc should be selected by listening with the field intensity measuring or receiving equipment antenna, outside the shield room. The antenna is placed a few inches from the outside of the screen room to be tested, several feet from the transmitting antenna. If the receiving equipment has a calibrated attenuator system, the signal generator and Power Amplifier may be operated at full output, and the attenuator set to give a convenient meter reading on the receiving equipment. Alternatively, the receiving equipment can be set to high sensitivity and the signal generator level adjusted to produce a convenient meter reading. The receiving antenna is then moved inside the screen room and placed within a few inches of the wall being tested. With full output from the 230A, the receiving antenna is used as a probe, along the seams, etc., and the point of maximum leakage is determined. The appropriate attenuator setting is read as the shielding attenuation figure. The procedure is repeated for the other walls of the screen room.

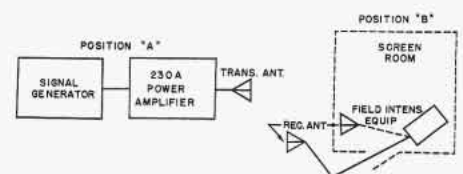

Figure 10. Setup for Screen Room Testing

A paper⁵ was given at the 1961 IRE Convention in New York which described another approach for measuring shielding performance at critical frequencies. One of these frequencies is the frequency (f_0) at which the screen room is resonant; usually between 50 and 200 MC. The frequency (f_0) can be readily detected using a grid-dip meter technique. The procedure, described in the IRE paper, for making the attenuation measurement is basically the same as previously described except that the measurement is made at the center of the screen room.

Other RFI Applications

Other RFI applications include powering of probes, loops, etc., for the testing of filters, shielded cables³, and small compartments. It is also possible to conduct "Standard Susceptibility to Radiation Tests."⁴ The output of the 230A Power Amplifier is sufficient to set up standard field intensities of greater than 1 volt per meter throughout most of the frequency range.

Additional Performance Data

The following performance data has been taken on the 230A, and, while not incorporated into the specifications, is considered typical of production units. Noise Figure — Approximately 8 db, or

about 4 microvolts per Kc of bandwidth. Power Output — It has been found that if enough drive is available, the 230A may produce as much as 16 watts for short periods of time without damage at some frequencies.

Conclusion

We have presented here many of the applications of the 230A Power Amplifier. Even at this writing, additional applications are in the making. These will be taken up in subsequent issues of the Notebook, as the details become known.

The author wishes to thank Mr. Fritz Popper of Shielding, Inc., Messrs. Sidney White and Guy Johnson of USASRD, and the BRC Engineering Staff for their comments and assistance given during the preparation of this article.

REFERENCES

1. Receiver Tests, IRE Standards 48-IRE-17.S1, 52-IRE-17.S1.
2. HF-VHF Communication System, AIRINC Characteristic No. 520-A, April 1954, Sections 4.4 through 4.6.
3. Proceedings of the 6th Conference on RFI, Oct. 1960, Armour Research Foundation, Illinois Institute of Technology.
4. MIL - E - 4957 - A (ASG), Enclosure, Electromagnetic-shielding, Demountable, Prefabricated for Electronics Test Purposes.
5. "Shielding Enclosure Performance Utilizing New Techniques," R. B. Schultz, Armour Research Foundation, D. P. Kanellakos, Stanford University, IRE 1961.

Using the FM Stereo Modulator

Willard J. Cerney, Sales Engineer

INTRODUCTION

With the approval of an FM Stereo broadcast system by the FCC on April 20, 1961, as specified in FCC Docket 13506, BRC designed and made available the Type 219A FM Stereo Modulator, a stable, easy to use, compact, economical source of the multiplex signal for use with FM Signal Generators, or for direct use with receiving multiplex adapters. Complete details of the basic design and circuitry of the Modulator may be found in Notebook No. 30. The purpose of this article is to describe the various tests which may be performed with this new instrument.

AREAS OF APPLICATION

The Type 219A FM Stereo Modulator finds application in the design, production testing, and servicing of FM multiplex receivers and adapters. The extreme versatility of the instrument in providing both standard and non-standard signal outputs make it ideal for laboratory use. The reliable, compact design, and the relatively high available output, permitting the operation of several test stations from a single modulator, make it well suited for production line applications. The functional controls and convenient output meter fulfill the requirements of service applications.



Figure 1. Type 219A FM Stereo Modulator

METHODS OF OPERATION

The Type 219A FM Stereo Modulator generates the complete multiplex signal, consisting of (L + R), (L - R), and 19 KC pilot and may be externally fed with an SCA sub-carrier. Employing either the internal 1 KC oscillator or an external tone or program source, the output may be used directly for the testing of multiplex adapters or other base-band circuitry in the 50 cps — 70 KC range.

Alternatively, the output of the modulator may be used to modulate a suitable FM Signal Generator, such as the BRC 202E or 202H, to provide a complete multiplex signal at RF, simulating transmissions in the 88-108 MC broadcast band. The Type 519A Adapter provides a convenient means of interconnecting these instruments and permits use of the modulating oscillator in

the 202E/H as an audio tone source to accomplish fidelity and distortion measurements from 50 cps to 15 KC without an external audio oscillator. The "set" position on the 219A output mode switch permits convenient setting of FM deviation on the signal generator to equate 100% multiplex output to 75 KC deviation.

DEFINITION OF TESTS

Essentially, there are four basic tests which may be performed with the Type 219A FM Stereo Modulator alone or in combination with a suitable FM Signal Generator.

1. Stereophonic or Channel Separation

Stereophonic or channel separation, usually expressed in db, is the ratio of the signal output from an excited

channel (L or R) to the residual or undesired output present on the non-excited channel (R or L).

2. (L + R) — (L - R) Crosstalk

(L + R) — (L - R) Crosstalk is the residual or undesired (L + R) or (L - R) output when either L = R or L = -R, respectively, in the multiplex signal.

3. Electrical Fidelity and Distortion

Electrical fidelity and distortion are measured conventionally on both (L) and (R) channels over the audio frequency range from 50 cps to 15 KC.

4. Non-Standard Signal Makeup

Non-standard signal makeup involves the setting of (L + R), (L - R), and/or 19 KC pilot levels over a range simulating the effects of propagation; eg., multipath transmission.

TEST SETUPS AND INTERCONNECTIONS

Typical equipment setup and interconnections for the tests, listed above, are shown in block diagram form in Figures 2 through 4. Figure 2 shows the connections for measurement of a multiplex adapter or base-band circuitry of a receiver. Figure 3 shows the connections for measurement of an FM receiver and multiplex adapter (or multiplex receiver). Figure 4 is essentially identical to Figure 3 except that a distortion analyzer, output meter, or other suitable instrument is connected in place of the oscilloscope for testing recovered audio.

AUXILIARY TEST EQUIPMENT REQUIREMENTS

The approved stereo broadcasting system employs base-band frequencies

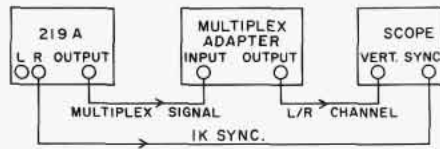

Figure 2. Connections for Checking Multiplex Adapter

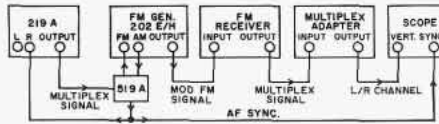

Figure 3. Connections for Complete System Test

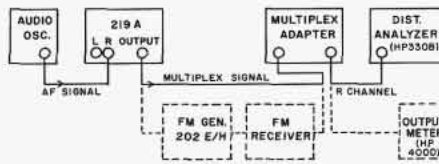

Figure 4. Connections for Fidelity and Distortion

over the range from 50 cps to 75 KC and it is essential that all auxiliary equipment have adequate bandpass capabilities to handle the complex waveforms with negligible time delay and amplitude variation over this range. A typical FM Signal Generator must have adequate FM modulation bandwidth in terms of sufficiently constant amplitude response and time delay in order to maintain stereo separation and should, of course, introduce minimum amplitude distortion.

While the levels of the various components of the multiplex signal can be readily and precisely adjusted using the peak reading output meter on the 219A, an external oscilloscope is desirable to measure and interpret the performance of the receiver or adapter under test. The oscilloscope used must possess minimum variation in amplitude response and linearity of phase vs.

frequency within $\pm 1/2^\circ$ from 50 cps to 70 KC. Figure 5A shows a typical oscilloscope pattern for a properly balanced multiplex signal (without 19 KC pilot). The flat base line indicates amplitude identity between (L + R) and (L - R); a small and tolerable amount of phase shift is indicated by the non-coincidence of the zero crossings on the base line. Figure 5B indicates amplitude unbalance (excess L - R) with approximately the same phase shift present in Figure 5A. It is important to note that this amplitude and phase shift, viewed on the oscilloscope, may be due to either improper adjustment of the 219A (readily checked on the output meter) or inadequate response characteristics of the oscilloscope. The peak voltmeter in the 219A may be relied on to indicate equality of L + R and L - R signal peak amplitudes to better than $\pm 1\%$.

OSCILLOSCOPE SYNCHRONIZATION

The oscilloscope may be synchronized with either the audio tone input signal or the 19 KC pilot carrier, generated in the 219A. The audio sync signal should be obtained from the external tone source or the right (R) input terminals of the 219A if the internal 1 KC tone oscillator is used. The 19 KC sync signal is available directly from a jack on the rear of the 219A. When audio tone synchronization is employed, the oscilloscope pattern for the complete multiplex signal, including 19 KC pilot carrier, is shown in Figure 5 C.

CHANNEL IDENTIFICATION

It is often necessary to identify left (L) and right (R) channels. While such identification can be made by observing the multiplex signal presentation with audio sync on an oscilloscope and ap-

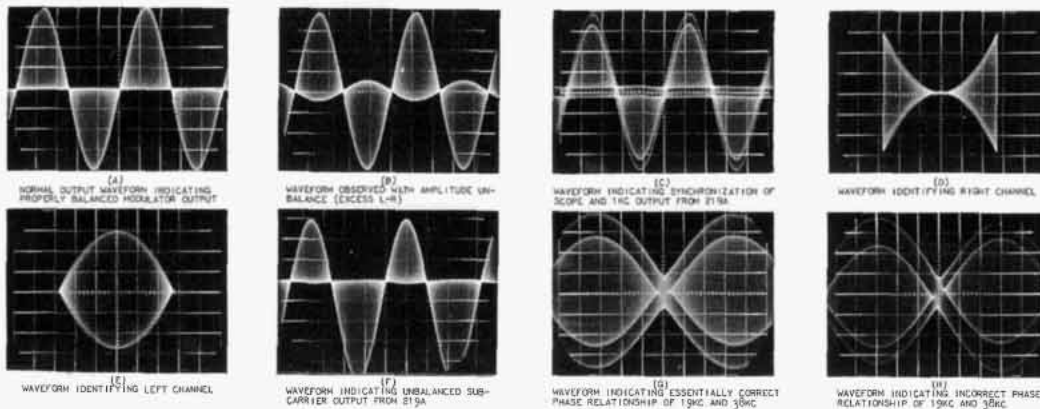

Figure 5. Waveforms 219A

plying the basic definitions in FCC Docket 13506, a far simpler and easier method is available. In this method, the multiplex signal is observed using the 19 KC sync output of the 219A, phase-shifted 45°, on the external input of the oscilloscope as shown in Figure 6. The phase-shift network, including typical component values, is shown in Figure 7. The oscilloscope patterns that will result from audio tone signals on either the right (R) or left (L) channel are shown in Figures 5D and 5E.

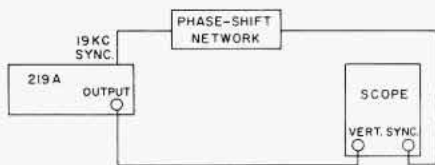

Figure 6. Connections for Channel Identification

MODULATOR BALANCE

The 38 KC carrier, generated by the balanced modulator, must, of course, be properly suppressed and the 219A is specified to produce less than 0.5% of 38 KC, when properly adjusted, compared to the level of the composite output. Proper balance will produce the waveform shown in Figure 5A; the waveform resulting from a grossly unbalanced sub-carrier output is shown in Figure 5F.

PHASING OF 19 KC AND 38 KC CARRIERS

Proper phasing of the 19 KC pilot carrier and the 38 KC carrier, modulated by (L - R), is essential for proper demodulation in the receiver. This phasing in the 219A may be readily verified by observing oscilloscope patterns of (L - R) and 19 KC pilot, employing the setup shown in Figure 6, except that the sync input of the scope is fed from the audio tone signal. A typical waveform with nearly correct phasing is shown in Figure 5G; the "diamond" pattern, in the center of the display, should be perfectly symmetrical. Incorrect phasing is shown in Figure 5H

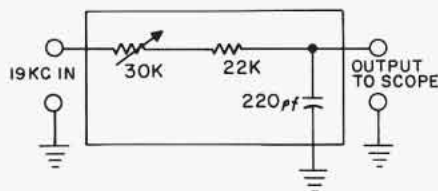

Figure 7. Phase Shift Network

TEST PROCEDURES

Stereophonic or Channel Separation

1. Adjust the 219A for standard multiplex output with an audio tone signal of the desired frequency applied to either the left (L) or right (R) channel.
2. Adjust frequency, modulation, and output of signal generator; also frequency and output of receiver. (This step is omitted if measurements are to be made directly at base-band, eliminating the signal generator).
3. Adjust receiver stereophonic controls for maximum audio output from channel on which audio tone signal has been applied and minimum output from undesired channel. If receiver or adapter has not been previously aligned, also adjust matrix to optimize these conditions.
4. Measure the audio output levels of the desired and undesired channels. Alternatively, the 219A audio tone modulating signal may be reversed to the opposite channel, thereby permitting reading of audio output to be made on either channel individually.

NOTES: (a) The receiver or adapter matrix and stereophonic balance controls are usually adjusted for optimum separation at 1 KC; measurements at other audio tone frequencies are then made without disturbing these settings.

(b) Since the audio output of the receiver or adapter under test may include 19 KC and/or 38 KC components, either low-pass filters (15 KC cut-off) should be inserted between the audio outputs and the indicating voltmeters or readout should be made on an oscilloscope, ignoring the 19 and 38 KC components in the measurement.

(L + R) — (L - R) Crosstalk

1. Repeat steps 1 thru 3 under separation.
2. Select L + R or L - R by means of the function switch and measure the undesired L + R or L - R output in the device under test. If a 19 KC pilot is required, cross-connect (parallel) the 219A left (L) and right (R) inputs to obtain (L - R) null or, conversely, provide left (L) and right (R) inputs so that L = -R, providing (L + R) null. (If the 219A internal 1 KC oscil-

lator is employed, switching may be conveniently performed by operating the matrix switch).

3. Measure the undesired (L + R) or (L - R) output, respectively, in the receiver or adapter under test.

NOTE: If an FM Signal Generator is employed for measurements through the RF section of a receiver, crosstalk, prior to demodulation due to overload in the receiver, may be detected by varying the RF output level of the signal generator.

Electrical Fidelity and Distortion

1. Repeat steps 1 thru 3 under separation.
2. Measure the audio output level from the receiver or adapter at selected frequencies in the 50 cps to 15 KC range.
3. Measure the distortion on the receiver or adapter audio output at selected frequencies in the 50 cps to 15 KC range.

NOTE: The audio tone input to the 219A must be readjusted for standard level at each test frequency.

Non-Standard Signal Makeup

Repeat steps 1 thru 3 under separation, modifying the levels of 19 KC pilot carrier, (L + R), and (L - R) to simulate the desired test condition.

NOTE: Receivers and/or adapters, especially those employing phase-locked sub-carrier oscillators, should be tested at various levels of 19 KC pilot carrier.

CONCLUSION

The Type 219A FM Stereo Modulator is an excellent source of FM stereo multiplex baseband signals for use with FM signal generators or for the direct use with receiving multiplex adapters. When used with the BRC Types 202E or 202H signal generators, the instrument provides modulated RF stereo multiplex signals which are of a quality better than that specified by FCC. The versatility and reliability of the instrument, together with its compactness of design, relatively high available output, functional controls, and convenient output meter, make it a valuable tool for use in the design, production testing, and servicing of FM multiplex receivers and adapters.

EDITOR'S NOTE

Q Meter Winner

The circuit displayed at the IRE show has been carefully measured on the Type 280A UHF Q Meter and the Q is **1421**. The winning estimate of **1450** was submitted by Mr. Jan Solomon, Management Engineer with Federal Electric Corp., Paramus, N. J. Second, with an estimate of 1480, is Mr. B. Nohre, an Engineer from Stockholm, Sweden.

Q estimates in the contest ranged from 1 to more than 25,000, with 40 persons guessing within 2% and 21 persons guessing within 1% of the measured Q. The distribution of estimates over the entire range of estimates is shown in the bar graph.

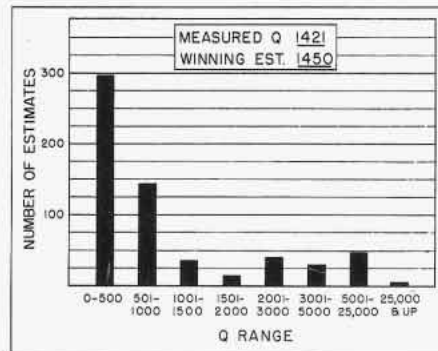

Distribution of Q Estimates

HEWLETT-PACKARD (CANADA) LTD. APPOINTED EXCLUSIVE CANADIAN REPRESENTATIVE

BRC is pleased to announce the appointment of Hewlett-Packard (Canada) Ltd., effective July 1, 1962, as our exclusive Canadian representative. With offices in Toronto, Ottawa, and Montreal, and warehouse facilities in Montreal, we are in a position to offer improved service to our many Canadian customers. Addresses and telephone numbers of these new offices are given on the back page of this issue.



Hewlett-Packard (Canada) Ltd.—Montreal Office

Engineering Representatives

ALBUQUERQUE, New Mexico
NEELY ENTERPRISES
6501 Lomas Blvd., N.E.
Telephone: 255-5586
TWX: AQ-172

ATLANTA, Georgia
BIVINS & CALDWELL, INC.
3110 Maple Drive, N.E.
Tel. Atlanta, Georgia 233-1141
TWX: AT 987

BINGHAMTON, New York
E. A. OSSMANN & ASSOC., INC.
149 Front Street
Vestal, New York
Telephone: STillwell 5-0296
TWX: ENDICOTT NY 84

BOONTON, New Jersey
BOONTON RADIO CORPORATION
P.O. Box 390
Telephone: OAKwood 7-6400
TWX: ROCKAWAY NJ 866

BOSTON, Massachusetts
INSTRUMENT ASSOCIATES, INC.
30 Park Avenue
Arlington, Mass.
Telephone: 648-2922
TWX: ARL MASS 253

CHICAGO 45, Illinois
CROSSLEY ASSOC., INC.
2501 W. Peterson Ave.
Telephone: BRoadway 5-1600
TWX: CG508

CLEVELAND 24, Ohio
S. STERLING COMPANY
5827 Mayfield Road
Telephone: Hillcrest 2-8080
TWX: HLCT 372

DALLAS 9, Texas
EARL LIPSCOMB ASSOCIATES
3605 Inwood Road
Telephone: Fleetwood 7-1881
TWX: DL 411

DAYTON 19, Ohio
CROSSLEY ASSOC., INC.
2801 Far Hills Avenue
Telephone: AXminster 9-7002
TWX: DY 306

DENVER 10, Colorado
LAHANA & COMPANY
1886 South Broadway
Telephone: PEarl 3-3791
TWX: DN 676

DETROIT, Michigan
S. STERLING COMPANY
21250 10-1/2 Mile Road
Southfield, Michigan
Telephone: 442-5656
TWX: SFLD 1141

FORT WORTH, Texas
EARL LIPSCOMB ASSOCIATES
Telephone: EDison 2-6667

HARTFORD, Connecticut
INSTRUMENT ASSOCIATES, INC.
734 Asylum Avenue
Telephone: 246-5686
TWX: HF 266

HIGH POINT, North Carolina
BIVINS & CALDWELL, INC.
1923 North Main Street
Telephone: 882-6873
TWX: H PT 454

HOUSTON 5, Texas
EARL LIPSCOMB ASSOCIATES
3825 Richmond Avenue
Telephone: MOhawk 7-2407
TWX: HO 967

HUNTSVILLE, Alabama
BIVINS & CALDWELL, INC.
Telephone: 534-5733
(Direct line to Atlanta)

INDIANAPOLIS 5, Indiana
CROSSLEY ASSOC., INC.
3919 Meadows Drive
Telephone: Liberty 6-4891
TWX: IP 545

LAS CRUCES, New Mexico
NEELY ENTERPRISES
114 South Water Street
Telephone: 526-2486
TWX: LAS CRUCES NM 5851

LOS ANGELES, California
NEELY ENTERPRISES
3939 Lankershim Blvd.
North Hollywood, California
Telephone: TRIangle 7-1282
TWX: N-HOL 7133

MONTREAL, P.Q., Canada
HEWLETT-PACKARD (CANADA) LTD.
8270 Mayrand Street
Telephone: 735-2273

ORLANDO, Florida
BCS ASSOCIATES
P.O. Box 6941
601 N. Fern Creek Drive
Telephone: CHerry 1-1091
TWX: OR 7026

PHOENIX, Arizona
NEELY ENTERPRISES
771 South Scottsdale Road
Telephone: 945-7601
TWX: SCSDL 547

PITTSBURGH 27, Pennsylvania
S. STERLING COMPANY
4232 Brownsville Road
Telephone: TUXedo 4-5515

PORTLAND, Oregon
ARVA, INC.
2035 S. W. 58th Avenue
Telephone: CApital 2-7337

RICHMOND 30, Virginia
BIVINS & CALDWELL, INC.
1219 High Point Avenue
Telephone: 355-7931
TWX: RH 586

ROCHESTER 25, New York
E. A. OSSMANN & ASSOC., INC.
830 Linden Avenue
Telephone: LUdlow 6-4940
TWX: RO 189

SACRAMENTO, California
NEELY ENTERPRISES
1317 Fifteenth Street
Telephone: Gilbert 2-8901
TWX: SC 124

SALT LAKE CITY 15, Utah
LAHANA & COMPANY
1482 Major Street
Telephone: HUnter 6-8166
TWX: SU 586

SAN DIEGO, California
NEELY ENTERPRISES
1055 Shafter Street
Telephone: AAcademy 3-8103
TWX: SD 6315

SAN FRANCISCO, California
NEELY ENTERPRISES
501 Laurel Street
San Carlos, California
Telephone: 591-7661
TWX: S CAR-BEL 94

SEATTLE 9, Washington
ARVA, INC.
1320 Prospect Street
Telephone: MAin 2-0177
TWX: SE 733

SPOKANE 10, Washington
ARVA, INC.
East 127 Augusta Avenue
Telephone: FAirfax 5-2557

ST. PAUL 14, Minnesota
CROSSLEY ASSOC., INC.
842 Raymond Avenue
Telephone: Midway 6-7881
TWX: ST P 1181

SYRACUSE, New York
E. A. OSSMANN & ASSOCIATES, INC.
P. O. Box 128
101 Pickard Drive
Telephone: GLenview 4-2462
TWX: SS 355

TORONTO, Ontario, Canada
HEWLETT-PACKARD (CANADA) LTD.
1415 Lawrence Avenue W
Telephone: 249-9196

TUSCON, Arizona
NEELY ENTERPRISES
232 South Tuscon Blvd.
Telephone: MAin 3-2564
TWX: TS 5981

BOONTON RADIO CORPORATION