

First Series EUP

**INSTRUCTION MANUAL
FOR THE
MODEL 190-A Q METER**



**BOONTON RADIO COMPANY
ROCKAWAY, NEW JERSEY
U. S. A.**



MANUAL CHANGES

MODEL 100A

Manual Serial Prefix

HP Part No. 00190-90020

To adapt this manual to instruments with other serial prefixes check for errata below, and make changes shown in tables.

Instrument Serial Prefix Make Manual Changes

Instrument Serial Prefix	Make Manual Changes
2536	1

Instrument Serial Prefix Make Manual Changes

Instrument Serial Prefix	Make Manual Changes

Δ New or revised item.

ERRATA

Page 29. Schematic

Reverse the polarity of CR300, 301.

CHANGE 1

Page 29. Schematic.

Delete R109, R106, C106 and R224.

Change V102 a type 537B tube to a semiconductor hot carrier diode, designated CR101.

Change V103 a type 538B tube to a type 6923/EA52 and add capacitor C115, 0.5pF from plate to cathode.

Page 25, 26. Electrical Components parts list.

Substitute the attached Reference Designator list for pages 25, 26. The Reference Designator List gives Hewlett-Packard part numbers for electrical parts before and after the instrument changes illustrated by the schematic changes above. An asterisk designates parts deleted by this change.

SECTION I

1.1 DESCRIPTION.

The Boonton Radio Corporation Model 190-A Q Meter operates in the vhf range, giving direct-reading measurement of Q values. A front-view photograph of the instrument appears in Figure III-1, showing the indicating meter, connection terminals and operating controls. Both the capacitance of the measuring circuit and the operating frequency are dial-indicated, making possible the calculation of various values of X, R, L, and C of a component under test. A summary of the characteristics and specifications of the Model 190-A is given in Section II.

The indicating meter is parallax-corrected to give precise readings by means of a blade-type meter needle and a mirror on the meter face. Three scales, in addition to the normal Q scale, read XQ, ΔQ and LO Q. The multiplier (XQ) scale extends the range of measurable Q values and may be used in conjunction with any of the other scales. The ΔQ scale directly indicates the difference in Q between two circuit conditions, eliminating calculations, while the expanded LO Q scale permits accurate reading of Q values below 100. Any one of these three scales is read by pressing the respective key switch, located below the indicating meter.

Also located under the meter dial are the Q Zero and XQ Zero potentiometer controls, used for electrical zeroing of the meter needle, and the SET XQ knob, which adjusts the output of the internal oscillator and permits the use of any multiplier value shown on the XQ Scale. The **FREQ. RANGE** switch and the MC knob and associated dial, at the left side of the instrumental panel, accurately control and indicate the frequency of the oscillator. At the upper right corner of the panel are the Q capacitor knob and MMFD dial. This knob drives the variable capacitor used in the Q measuring circuit and the dial permits direct-reading of its capacitance.

The ΔQ BALANCE controls, located in the lower right corner of the instrument panel, enable the operator to zero the needle of the indicating meter on the ΔQ scale when measuring small differences in Q. The outer knob, directly driving the dial, is the coarse balancing control, while the inner knob gives vernier adjustment.

A power switch is provided at the extreme lower right and the pilot lamp (lower left) lights when the instrument circuits are energized.

Four binding-post terminals near the right front corner of the cabinet top permits external components to be connected to the measuring circuit. Inductors which can be resonated in the frequency range of the Model 190-A are connected directly across the COIL terminals for Q measurement. Small capacitors and certain other components are connected to the CAP. terminals, and measure in conjunction with stable inductors. The high and low potential COIL terminals

and the high and ground potential CAP. terminals are clearly labeled.

An accessory set of stable reference coils, the Type 590-A inductors, is available for use with the BRC Model 190-A Q Meter. These specially-constructed coils permit checking instrument operation and are employed in the Q measurement of components other than inductors.

The Model 190-A Q Meter may be used *only* on a 60-cycle a-c power source. For 50 cps operation, the Model 190-AP Q Meter, available on special order, must be used. This model may be operated on either 50-cycle or 60-cycle power lines, but does not provide internal regulation of line voltage. It is recommended that the user employ external regulating facilities to avoid the inconvenience of possible zero shifts and variations in the oscillator output caused by line irregularities. Without regulation, the accuracy of the instrument is only slightly impaired.

SECTION II

2.1 SPECIFICATIONS.

FREQUENCY

Total Range20 to 260 mc (continuously variable)

BandsFour: 20 to 40 mc
40 to 80 mc
80 to 160 mc
160 to 260 mc

Calibration

Tolerance $\pm 1\%$

Q MEASUREMENTS

Total Range5 to 1200

Q Voltmeter

Scale50 to 400 (direct-reading)

LO Q Scale10 to 100 (direct-reading)

XQ (Multiplier)

Scale0.5 to 3.0

Measurement

Circuit Q of 400, read directly on the meter, is accurate to $\pm 7\%$ to 100 mc and to $\pm 15\%$ to 260 mc.

DIFFERENCE (ΔQ) MEASUREMENTS

Range0 to 100 (direct-reading; also used in combination with XQ multiplier factor)

INTERNAL RESONATING CAPACITOR

Range7.5 μpf to 100 μpf (direct-reading)

Calibrations0.1 μpf increments

Control Knob

Rotation $9\frac{1}{4}$ useful turns.

Calibration

ToleranceBelow 20 μpf : $\pm 0.2 \mu\text{pf}$
Between 20 and 50 μpf :
 $\pm 0.3 \mu\text{pf}$

	Between 50 and 100 μf : $\pm 0.5 \mu\text{f}$
TUBES	
Quantity	Six
Types	Two 5718 (V-100, V-101, oscillator tubes) One 537A, selected 9005 (V-103, Q voltmeter diode) One 537B, selected 9005 (V-102, XQ voltmeter diode) One 538A, selected 12AT7 (V-200, Q meter amplifier) One OB2 (V-300, voltage regulator tube)
POWER SOURCE — 190-A	
Voltage	95 to 130, internally regulated
Frequency	60 cps only
Power required	.55 watts
POWER SOURCE — 190-AP	
Voltage	95 to 130, internally regulated
Frequency	50 cps only
Power required	.55 watts
DIMENSIONS	
Length	13 $\frac{3}{4}$ inches
Width	10 inches
Height	10 inches
WEIGHT	190-A 25 pounds 190-AP 25 pounds

$$\omega = 2\pi f$$

C = capacitance in farads

L = inductance in henries

R = resistance in ohms

3.2 INSTALLATION.

Make certain that the supply voltage of the line to which the Model 190-A will be connected is rated at 60 cps. If operation on 50 cps is necessary, Model 190-AP must be used, preferably with external regulation.

Connect the binding post at the back of the cabinet to a good ground, to improve stability.

Check and, if necessary, adjust the mechanical zero on the face of the Q voltmeter.

When the power switch is turned ON, the pilot lamp in the lower left corner of the front panel should light. After about one minute, the Q voltmeter needle should show a reading when the XQ key is depressed (unless the SET XQ knob is fully counterclockwise). Such a reading indicates that the internal oscillator is furnishing an output signal.

3.3 OPERATING HINTS AND CAUTIONS.

When the Model 190-A is first received and put into operation, it is suggested that careful measurements be made, using a set of Boonton Radio Corporation Type 590-A inductors, and that the data be recorded and filed. At least one measurement should be made near each end of each frequency band, with the exception of 20 and 260 mc. These recommended measurements provide a set of standard data for each individual Q Meter, which will be available for reference and comparison should it ever become necessary to perform calibration or other maintenance work on the equipment.

Since the 190-A Q meter operates in the vhf range, all precautions normally observed at these frequencies, such as lead dress, etc., should be taken to insure accurate measuring results. To reduce lead inductance and stray capacitance to a minimum, use heavy, straight leads and keep them as short as possible. If it is necessary to measure an unshielded inductor, however, a compromise in lead length is recommended to avoid too close proximity of the specimen to the instrument case.

Reference coils, other than the Type 590-A, used in conjunction with measuring other components, should always be shielded coils, to eliminate the possibility of errors which can result from coupling with components under test.

Note that the LO side of the COIL connection terminals is *not* at ground potential; the test oscillator voltage is injected between this terminal and ground. Therefore, specimens which are grounded or which have large capacitances to ground cannot be measured at the COIL terminals. Care should also be taken that specimens do not become grounded accidentally to the instrument case.

SECTION III

OPERATING INSTRUCTIONS

3.1 GENERAL.

This section describes the recommended operating procedures for the use of the Model 190-A Q Meter in measuring and calculating the parameters of coils, capacitors and resistors. Q measurements are made either by presetting the oscillator frequency and resonating the component or circuit under test with the internal Q capacitor, or by setting the capacitor to a desired value and adjusting the frequency controls to obtain resonance. All operating controls and the connection terminals are shown in Figure III-1.

The readings obtained with the instrument are of *indicated circuit Q*, since the resonating capacitor, vacuum tube voltmeter, and insertion impedance are included in the measuring circuit. For determining Q of the component under test in certain cases, these readings may require correction. A discussion of scale factors, circuit residuals and the resulting corrections is included in Section V.

3.1.1 THE UNITS USED THROUGHOUT THIS INSTRUCTION MANUAL ARE AS FOLLOWS:

f = frequency in cycles per second

f mc = frequency in megacycles per second

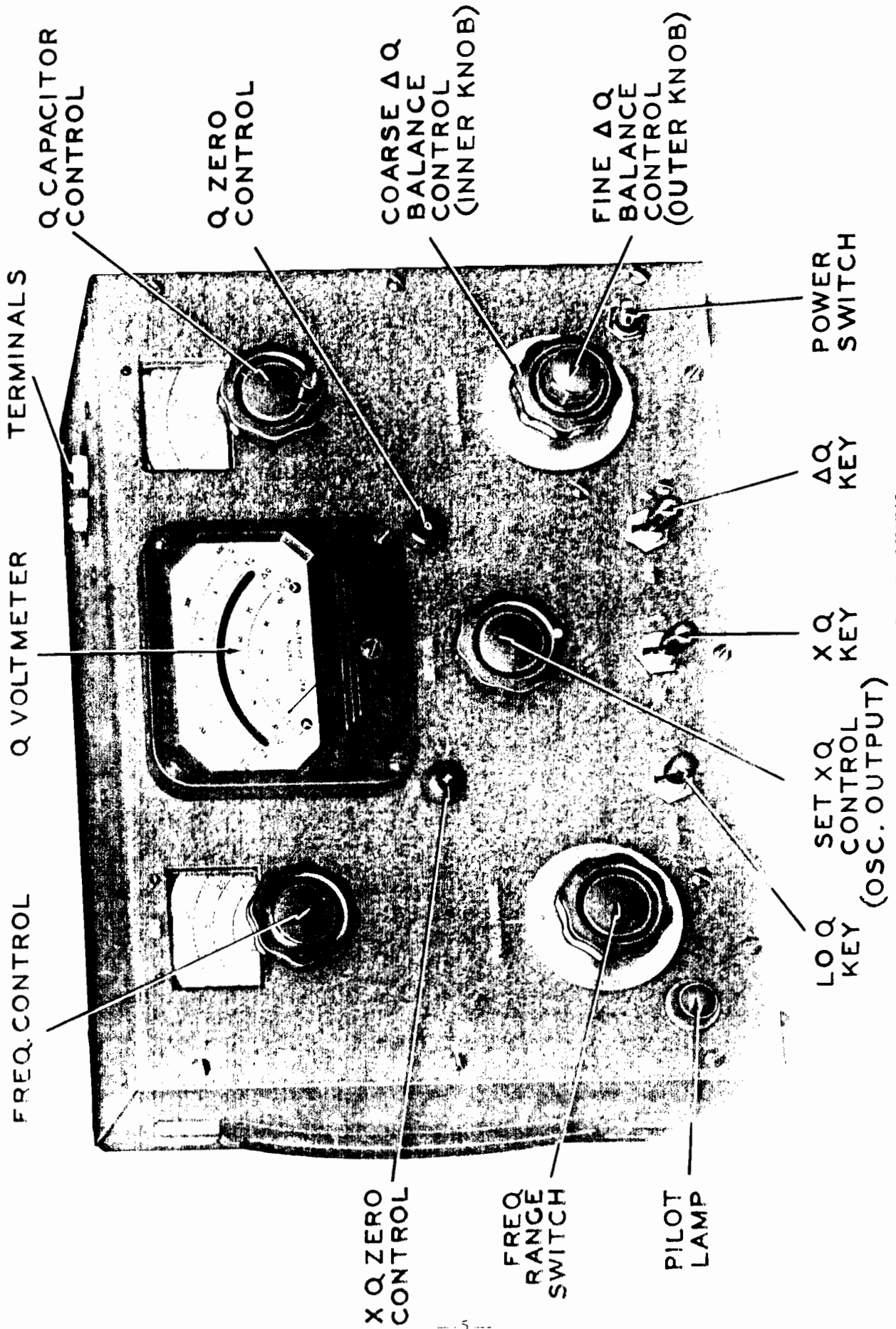

FIG. III-1 FRONT PANEL VIEW

In connecting specimens to the instrument terminals, tighten the binding posts securely to minimize contact resistance. When two components are connected in series between the binding posts, the floating joint should also be made as tight as possible, preferably by soldering.

The placement of components with respect to each other and to ground becomes especially important as the frequency increases. In making comparative measurements of several specimens, keep the lead lengths equal and mount the specimens in the same relative position each time. To obtain precise measurements of a component which will later be used in an equipment, it may be desirable to mount it in the same position relative to ground which it will occupy in the equipment. Slight differences in placement may result in considerable variations of Q , capacitance, and resistance.

When making measurements which involve a small difference in Q values, it is advantageous to use the ΔQ feature of the instrument to obtain maximum accuracy. The relative sensitivity of the ΔQ and Q scales is 4:1, affording greater ease and precision in reading small difference values on the ΔQ scale.

3.4 METHODS OF CONNECTING COMPONENTS.

There are three basic methods of connecting external components to the measuring circuit of the Model 190-A for Q measurement. The method which will be employed in a given case depends upon the impedance to be measured.

3.4.1 COILS.

Most coils are measured by connecting the coil directly to the COIL terminals on top of the instrument, as shown in Figure III-2(a). The measuring circuit, which includes the coil, the internal Q capacitor, and the Q vacuum tube voltmeter, is then resonated by adjusting either the frequency or the capacitance and the indicated circuit Q is read on the panel meter.

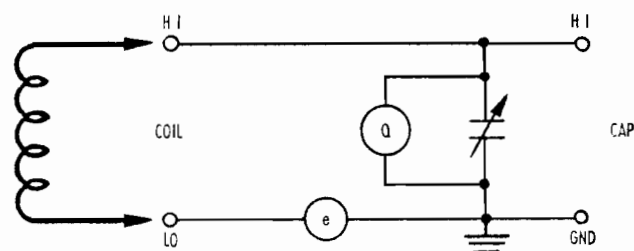

Fig. III-2a Coil Measurement

3.4.2 PARALLEL CONNECTION.

Components which have high impedance, such as large value resistors and inductors or small capacitors, are measured by connecting them in parallel with the measuring circuit. This connection to the CAP. terminals is shown in Figure III-2(b). Before the unknown is added, however, the measuring circuit must be resonated, using a Type 590-A inductor or other stable coil, to

establish reference values of Q and of C . When the component under test is added and the circuit re-resonated, the altered values of Q and C are used, with the originals, to calculate the parameters of the unknown. In most cases parallel connection is the preferred method.

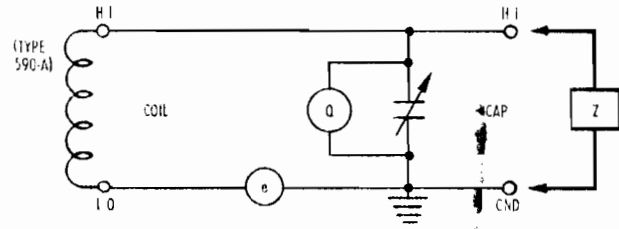

Fig. III-2b Parallel Connection

3.4.3 SERIES CONNECTION.

Low-impedance components to be measured are connected in series with the measuring circuit. This is accomplished by connecting the unknown between the LO terminal and one end of the Type 590-A reference coil, as shown in Figure III-2(c). The other end of the reference coil is connected to the HI side of the coil terminals. A heavy strap, as illustrated, is usually employed to short the unknown while the measuring circuit is resonated to establish a reference condition. The shorting strap is then removed or opened and the circuit re-resonated. This permits the unknown to be physically connected even though electrically out of the circuit and eliminates possible errors by maintaining the relative positions of the reference coil and the unknown.

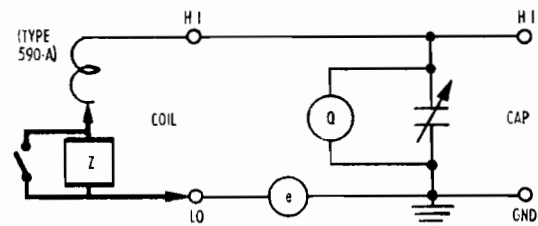

Fig. III-2c Series Connection

3.5 OPERATING AND MEASURING PROCEDURES.

3.5.1 WARM-UP AND INITIAL SETTING.

The locations of the various controls are shown in Figure III-1. The procedure is as follows:

3.5.1.1 Check and, if necessary, adjust the mechanical meter zero.

3.5.1.2 Turn the power switch ON.

3.5.1.3 Allow the instrument a few minutes to warm up. For precise measurements, the warm-up period should be at least 30 minutes.

3.5.1.4 Connect a coil to the COIL terminals on the top of the instrument to provide a d-c path for the Q voltmeter.

3.5.1.5 Turn the SET XQ control to zero (fully counterclockwise).

3.5.1.6 Using the Q zero potentiometer, zero the meter needle. Depressing the LO Q key increases the meter sensitivity and permits the zero to be set more accurately. Alternately pressing and releasing, or "pumping", the LO Q key permits the accuracy of the zero setting to be checked. The setting is correct if the needle remains stationary.

3.5.1.7 Depress the XQ key and zero the meter needle with the XQ zero potentiometer. The LO Q key may again be operated while the XQ key is depressed, to permit greater accuracy in setting the zero.

The instrument is now ready for use.

3.5.2 COIL MEASUREMENTS.

Most coils are measured by the procedure given below and the values of Q, C and f (frequency) are read directly from the indicating meter and dials of the instrument. With these values, the series inductance and series resistance of the coil may be calculated.

3.5.2.1 Connect the coil to be measured to the COIL terminals on the top of the instrument (after the "Warm-up and Initial Setting" has been completed). This method of connection is illustrated in Figure III-2(a).

3.5.2.2 Set the **FREQ. RANGE** switch to the proper range and the frequency control (MC knob and dial) to the frequency desired. Turn the SET XQ knob about one-quarter turn clockwise to apply oscillator voltage.

3.5.2.3 Resonate the coil by adjusting the Q capacitor control (MMFD knob and dial) to obtain maximum meter deflection. As an alternative, the Q capacitor may be set to a desired value and the measuring circuit resonated by varying the oscillator frequency.

3.5.2.4 Depress the XQ key and turn the SET XQ control until the meter needle reads the desired multiplying factor, on the XQ scale. (The unity factor is calibrated with the highest accuracy and is recommended for use, whenever possible.)

3.5.2.5 Recheck the tuning for resonance.

3.5.2.6 Read the indicated Q on the Q (top) scale of the meter.

3.5.2.7 If XQ was set to any value other than unity, multiply the indicated Q reading by the appropriate XQ factor. This gives the Q of the tuned measuring circuit and in most cases this value is essentially equal to the effective Q of the unknown coil. The value of C may be read from the MMFD dial and the value of f from the frequency dials. If the indicated Q is less than 100, the LO Q scale may be used to obtain a more accurate reading, by depressing the LO Q key. This reading also must be multiplied by XQ.

To calculate the series inductance and series resistance of the coil being measured, the values of Q, C

and f obtained are substituted in the following formulas:

Effective Series Inductance

$$L_s = \frac{1}{\omega^2 C} \quad (1)$$

Effective Series Resistance

$$R_s = \frac{1}{\omega C Q} \quad (2)$$

If precision measurements are required, refer to Section V for a discussion of corrections which may be applied. If an inductance is found to be too large to be measured by the method described above, parallel measurement (below) may be employed. For very small inductances, the series method (below) will make measurement possible. If desired, equivalent parallel components may be calculated using the formulas of Table III-1-B.

3.5.2.8 PARALLEL MEASUREMENT.

The parameters of high impedance unknowns are calculated by measuring the effects on Q and C of the resonant measuring circuit when the unknowns are added in parallel with the circuit. The parallel method of connection is shown in Figure III-2(b). Large values of resistance and inductance and small values of capacitance are measured in this manner. To resonate the measuring circuit, a Type 590-A inductor or other stable reference coil must be connected to the COIL terminals and the internal resonating capacitor and oscillator frequency adjusted as desired to produce resonance. When this initial condition is obtained, the indicated Q and the reading of the MMFD dial are recorded as Q_1 and C_1 , respectively. After the instrument is re-resonated with the unknown impedance in parallel with the measuring circuit, the altered values of these readings are recorded as Q_2 and C_2 . The frequency, f, does not change.

The values obtained with this procedure may then be applied in the formulas given in Column 1 of Table III-1-A to calculate the effective parameters of the unknown. Equivalent series parameters may be calculated by use of the equations in Table III-1-B.

It is convenient in many parallel measurements to use the ΔQ feature of the 190-A, which yields the quantity ($Q_1 - Q_2$) as a direct reading on the ΔQ scale. The ΔQ scale gives a more accurate result in cases where Q_2 is nearly equal to Q_1 . The procedure is described in the paragraph, " ΔQ Measurement", below.

3.5.2.9 SERIES MEASUREMENT.

Low impedances—small values of inductance and resistance and large values of capacitance—are measured by their effects on the measuring circuit when added in series with it. The connection is illustrated in Figure III-2(c) and a heavy shorting strap is usually used in conjunction with the unknown impedance, as described under "Methods of Connecting Components" (See page 6). The measuring procedure is the same as that used for parallel measurement. The measuring circuit is ini-

TABLE III-1-A
FORMULAS FOR CALCULATING IMPEDANCE PARAMETERS
FROM PARALLEL AND SERIES MEASUREMENTS

Column 1	Column 2
Parameters from Parallel Measurements	Parameters from Series Measurements
Effective Q of Unknown	Effective Q of Unknown
$Q = \frac{Q_1 Q_2 (C_2 - C_1)}{\Delta Q C_1} \quad (4)$	$Q = \frac{Q_1 Q_2 (C_1 - C_2)}{C_1 Q_1 - C_2 Q_2} \quad (9)$
Effective Parallel Resistance of Unknown	Effective Series Resistance of Unknown
$R_p = \frac{Q_1 Q_2}{\omega C_1 \Delta Q} \quad (5)$	$R_s = \frac{C_1 Q_1 - Q_2}{\omega C_1 Q_1 Q_2} \quad (10)$
Effective Parallel Reactance of Unknown	Effective Series Reactance of Unknown
$X_p = \frac{1}{\omega (C_2 - C_1)} \quad (6)$	$X_s = \frac{(C_1 - C_2)}{\omega C_1 C_2} \quad (11)$
Effective Parallel Inductance of Unknown	Effective Series Inductance of Unknown
$L_p = \frac{1}{\omega^2 (C_2 - C_1)} \quad (7)$	$L_s = \frac{(C_1 - C_2)}{\omega^2 C_1 C_2} \quad (12)$
Effective Parallel Capacitance of Unknown	Effective Series Capacitance of Unknown
$C_p = C_1 - C_2 \quad (8)$	$C_s = \frac{C_1 C_2}{(C_2 - C_1)} \quad (13)$
Note 1: The sign of the quantity $(C_2 - C_1)$ indicates the type of effective reactance. A positive quantity results from an inductive reactance and a negative from a capacitive reactance.	Note 1: The sign of the quantity $(C_2 - C_1)$ indicates the type of effective reactance. A positive quantity results from a capacitance reactance and a negative from an inductive reactance.
Note 2: The sign of the quantity $(C_2 - C_1)$ should be disregarded in Equation 4 above.	Note 2: The sign of the quantity $(C_1 - C_2)$ should be disregarded in Equation 9 above.

TABLE III-1-B
FORMULAS RELATING EQUIVALENT SERIES AND PARALLEL COMPONENTS

$$Q = \frac{X_s}{R_s} = \frac{\omega L_s}{R_s} = \frac{1}{\omega C_s R_s} = \frac{R_p}{X_p} = \frac{R_p}{\omega L_p} = R_p \omega C_p$$

General Formulas	Formulas for Q greater than 10	Formulas for Q less than 0.1	General Formulas	Formulas for Q greater than 10	Formulas for Q less than 0.1
$R_s = \frac{R_p}{1 + Q^2}$	$R_s = \frac{R_p}{Q^2}$	$R_s = R_p$	$R_p = R_s (1 + Q^2)$	$R_p = R_s Q^2$	$R_p = R_s$
$X_s = X_p \frac{Q^2}{1 + Q^2}$	$X_s = X_p$	$X_s = X_p Q^2$	$X_p = X_s \frac{1 + Q^2}{Q^2}$	$X_p = X_s$	$X_p = \frac{X_s}{Q^2}$
$L_s = L_p \frac{Q^2}{1 + Q^2}$	$L_s = L_p$	$L_s = L_p Q^2$	$L_p = L_s \frac{1 + Q^2}{Q^2}$	$L_p = L_s$	$L_p = \frac{L_s}{Q^2}$
$C_s = C_p \frac{1 + Q^2}{Q^2}$	$C_s = C_p$	$C_s = \frac{C_p}{Q^2}$	$C_p = C_s \frac{Q^2}{1 + Q^2}$	$C_p = C_s$	$C_p = C_s Q^2$

tially resonated with a reference coil and strapped unknown connected to the COIL terminals and Q_1 and C_1 are recorded. After the shorting strap is opened, inserting the unknown impedance in series, the circuit is re-resonated to obtain the values of Q_2 and C_2 .

These values, with f , may then be substituted in the formulas given in Column 2 of Table III-1-A to determine the effective series parameters of the impedance under measurement. The equivalent parallel parameters may also be determined by use of the formulas in Table III-1-B.

A d-c path must always be provided across the COIL terminals. If the unknown impedance will not pass d-c, the unknown should be shunted by a suitable choke. If the choke has a reasonably high Q and is used near its self-resonant frequency, it will present a high impedance and will have negligible effect on the measurements. Such a choke is conveniently made by cutting a piece of #38 wire to a length of 0.3λ at the desired frequency of measurement. The wire may be wound on a polystyrene form $\frac{1}{4}$ inch in diameter and the ends connected across the unknown.

The ΔQ scale may be used for accuracy in reading small differences in Q . Refer to " ΔQ Measurement" in this section for the procedure.

3.5.2.10 LO Q MEASUREMENT.

The LO Q function of the 190-A provides a more sensitive meter range for accurate measurement of Q values which are less than 100 on the regular Q scale of the indicating meter. The relative sensitivity of the Q and LO Q scales is 1:4.

The LO Q scale is read by simply depressing the LO Q key. Multiply the LO Q reading by the appropriate XQ factor, to obtain indicated Q .

3.5.2.11 ΔQ MEASUREMENT.

The ΔQ feature of the instrument permits direct meter indication of small differences in Q values before and after an unknown impedance is added to the measuring circuit in series or in parallel.

After a reference coil is connected and initial resonance of the measuring circuit is obtained, the coarse ΔQ BALANCE control is set to the approximate reading indicated on the Q scale of the meter. With the ΔQ key depressed, the meter needle is set to zero on the ΔQ scale, using both the coarse and fine ΔQ BALANCE controls, as necessary. This procedure balances the instrument for use as a differential voltmeter.

The unknown impedance is connected in series or parallel with the measuring circuit and the circuit is re-resonated, after which the ΔQ key is operated and the Q difference is read directly on the ΔQ scale. A more accurate resonance is obtained by resonating with the ΔQ key depressed. If the XQ factor is other than unity, it must be applied to the ΔQ reading.

3.5.3 MEASUREMENT OF CAPACITORS.

The method used to obtain the C , Q and other parameters of a capacitor depends upon the impedance of

the component. In both series and parallel methods, it is important to employ short leads to minimize lead capacitance and inductance, especially when measuring capacitors at high frequencies. Further information on measurement of capacitors is given in the Boonton Radio Corporation's "Manual of Radio Frequency Measurements".

3.5.3.1 SMALL CAPACITORS.

Small capacitors, with values of less than about 90 mmf, are connected and measured by the parallel method. It is necessary to select a Type 590-A inductor which will resonate at the desired frequency with the total capacitance of the unknown and the Q capacitor. The internal resonating capacitor itself should be set near maximum (100 mmf) before the measuring circuit is initially resonated.

The parameters of the capacitor being measured may be calculated by using the formulas given in Column 1 of Table III-1-A.

3.5.3.2 LARGE CAPACITORS.

A series connection to the measuring circuit is used to measure larger capacitors. The capacitor must be shunted by a suitable choke, as described under "Series Measurement" (see page 7), to provide a d-c path across the COIL terminals. The capacitor under measurement should be in place but shorted out with a heavy copper strap or jumper and the internal Q capacitor should be pre-set near its minimum value during the initial resonance.

In some high-frequency cases the effective reactance of the unknown capacitor may be inductive; in these instances, C_1 will be greater than C_2 .

The effective parameters of the unknown may be calculated by using the formulas in Column 2 of Table III-1-A.

3.5.4 MEASUREMENT OF RESISTORS.

Resistors may be measured in series with the Q circuit as indicated in Figure III-2(c) or in parallel as indicated in Figure III-2(b). The resistance values which may be measured by each of these methods is indicated in Figure III-3. Resistances which fall within the space between the two cross hatched areas may be measured by connecting them in series with a small capacitor and measuring the combination by the parallel method.

3.5.4.1 SMALL RESISTORS.

Resistors whose values fall within the block marked "Series" in Figure III-3 are measured by the series method. The effective series resistance is calculated by applying the resulting readings in the proper formula in Table III-1.

The sign of the effective reactance is indicated by a comparison of C_1 and C_2 . If C_1 is greater than C_2 , the effective reactance is inductive and the effective series inductance is obtained from the proper formula in Table III-1.

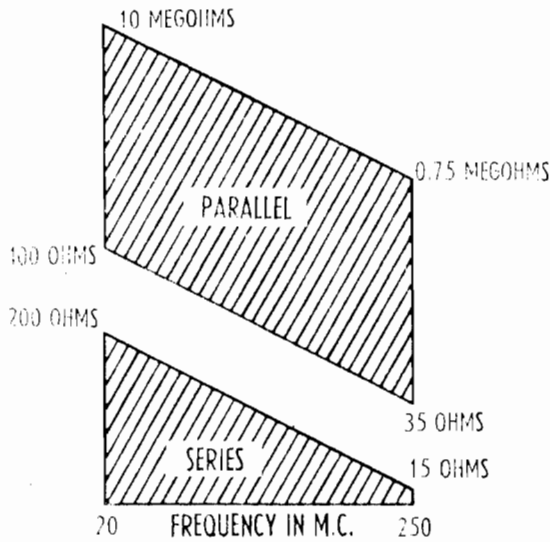

FIG. III-3 RESISTANCE RANGES

3.5.4.2 LARGE RESISTORS.

Resistors whose values fall within the range of the block marked "Parallel" (Figure III-3) are connected to the CAP terminals of the instrument and measured by the parallel method. The effective parallel resistance is given by formula (5) in Table III-1-A.

If the effective reactance is capacitive (C_1 greater than C_2), the effective parallel capacitance is given by formula (8) in Table III-1-A.

SECTION IV

4. PRINCIPLES OF OPERATION.

4.1 GENERAL.

The BRC Model 190-A Q Meter divides functionally into three major sections: an r-f section, a measuring section and a power supply.

Figure IV-1 shows in simplified form the basic principle upon which the instrument operates. The diagram shows that what is actually measured is the ratio between the voltage developed across the capacitive portion (C) of the resonant test circuit and the voltage injected into the circuit (across L-106).

$$Q = \frac{X}{R} = \frac{V_c}{e}$$

where e is the voltage injected

into the test circuit and V_c is the voltage measured across the capacitor at resonance. e is maintained at 0.01 volt; therefore, 100 V_c will be equal to the circuit Q and the meter can be calibrated to read Q directly. This has been done in the 190-A. In the equation above, X is the reactance of either the capacitor or the inductor, the values being equal at resonance; R is the sum of the resistances of the unknown and of the internal circuit, and the resultant Q reading is that

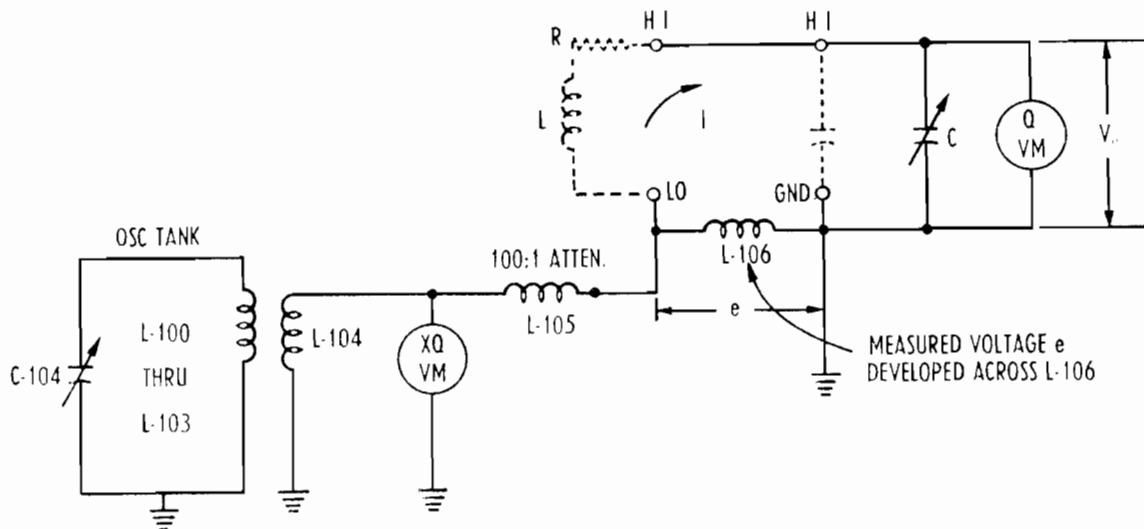

LET R TOTAL CIRCUIT RESISTANCE AT RESONANCE $I = \frac{e}{R}$

THE VOLTAGE ACROSS L OR C $|V_c| = IX_c = IX_L$

THEN $|\frac{V_c}{e}| = \frac{X_c}{R} = \frac{X_L}{R} = Q$

FIG. IV-1 BASIC OPERATING PRINCIPLE

of the *circuit*, rather than of the unknown component alone. In most cases the Q of the unknown and the Q of the circuit differ by a negligible amount.

4.2 R-F SECTION.

The signal applied across the resonant test circuit is furnished by a modified push-pull Colpitts oscillator, shown in the full schematic of the 190-A, Figure IV-2. The two oscillator tubes, V-100 and V-101, are type 5718 subminiatures which are built into the oscillator turret housing to maintain short leads. The oscillator frequency is tuned by dual variable capacitor C-104, adjusted by means of the MC knob in the upper left corner of the front panel. Capacitor C-103 is used to recalibrate the frequency dial when the oscillator tubes are replaced (see Section VI, page 18).

The tank coils, L-100 through L-103 are contained in a turret operated by the **FREQ. RANGE** knob in the lower left corner of the front panel. This turret is provided with a detent cam and a microswitch, S-101, which cuts off the oscillator plate supply voltage to protect the oscillator tubes while switching bands.

The oscillator output is coupled by loop L-104 to a specially-designed transmission line (Figure IV-2). The transmission line (L-105) and injection inductance (L-106) form an inductive attenuator with an attenuation ratio of 100:1. The voltage at the input of the transmission line is monitored by the XQ voltmeter, which utilizes a type 9005 diode, V-102. A special sliding adjustment is incorporated in the transmission line for accurate setting of the attenuation ratio at the factory. *Do not attempt to change this adjustment.*

The oscillator plate voltage is adjusted and controlled by the SET XQ potentiometer, R-223, so that the signal voltage at L-104 is maintained at a constant value, normally 1 volt. When the voltage at L-104 is 1 volt, the voltage across L-106 is 0.01 volt. This voltage is injected in series with the resonant circuit containing the unknown to be measured.

The external terminals provide for connection of the specimens to be measured. The internal precision resonating "Q capacitor", C-108, is connected across the CAP terminals. Q voltmeter diode V-103 (type 9005) is connected directly across the Q capacitor and the rectified signal voltage is passed to the measuring section of the instrument.

The internal variable (resonating) "Q capacitor", C-108, which is the heart of the measuring circuit, is of special construction to keep its residual inductance and resistance at a minimum, while retaining mechanical strength and calibration accuracy. The rotor plates are connected in parallel to ground by spring contact fingers. The stator is of one-piece construction, milled from hexagonal bar stock, so that the plates are connected along their entire outside perimeter. This design permits a reduction of the series inductance between the high potential and ground terminals to approximately 0.0024 μ h.

Dielectric losses are reduced by mounting the stator by means of two rods soldered to it and to metallized end-slots in the U-shaped low-loss steatite support. The stator plates extend only about 160° to allow the capacitor to track linearly down to the unusually low value of 10 μ pf.

To reduce further the internal inductance of the instrument, the Hi terminals are mounted directly to the top of the capacitor stator, are of relatively large diameter, and are kept as short as possible.

4.3 MEASURING SECTION.

The measuring section is comprised of the diode VTM circuits, including the dual d-c meter amplifier, the meter itself, and the associated switching, calibrating and adjustment circuits.

Since the Q voltmeter is connected directly across the resonant circuit, it is important that it have a high impedance. A diode-type voltmeter is used in preference to a triode circuit since the diode has a higher input impedance at high frequencies. The diode cannot furnish sufficient power to operate the meter without unduly loading the resonant circuit; therefore, a d-c amplifier is used to provide the necessary power. The d-c amplifier also serves as a simple and efficient means of isolating the bucking and balancing voltages required and supplying a low-impedance input source for the meter.

The d-c amplifier, V-200, is a type 12AT7 twin triode, connected for cathode-follower output to the meter and its appropriate multipliers and calibrating potentiometers. Potentiometer R-208 is connected in the cathode return circuit—between the cathodes of the two triode sections—and is used to balance the no-signal output of the tube when a new tube is installed (see section VI, page 18).

The switching, calibrating and zeroing circuits which interrelate the various functions of the instrument, as well as the multiplying resistances, may be seen by reference to the schematic, Figure IV-2.

4.3.1 XQ CIRCUIT.

When the XQ switch is operated the grid of one section of the d-c amplifier tube V-200 is connected to the cathode of the XQ voltmeter diode V-102. The amplifier output is applied to the meter through the XQ calibrating potentiometer, R-216, and an additional multiplier resistor. The other side of the meter is connected to the cathode of the other triode section of the d-c amplifier, which provides a stabilizing action. The grid of the second triode is fed by a bucking voltage derived from the -105v d-c regulated supply through the XQ zero adjustment potentiometer, R-200. This pot is adjusted by the front-panel knob designated "X".

The XQ scale on the meter is calibrated to read "1" when the oscillator output is 1 volt, measured at the input to the transmission line. At 2 volts, the XQ scale reads "0.5"; at 0.5 volt, it reads "2", etc., thus indicating the multiplying factor to be used with the Q voltmeter scale reading.

4.3.2 Q VOLTMETER CIRCUIT.

The Q voltmeter circuit obtains its voltage from the cathode to diode V-103, type 9005, the plate of which is connected to the HI side of the resonant measuring circuit of the 190-A.

In other respects, the operation of this circuit is much the same as that of the XQ circuit described above. R-215 is the calibrating potentiometer and R-219 the multiplier resistor. R-202 is the front-panel zeroing adjustment control, "Q".

4.3.3 LO Q VOLTMETER CIRCUIT.

The LO Q voltmeter circuit operates in exactly the same manner as the Q voltmeter circuit, except that its sensitivity is four times as great, giving accurate Q readings down to 5. The LO Q circuit uses R-213 and R-217 as the calibrating potentiometer and multiplier resistor, respectively. The front-panel Q zero adjustment, R-202, also zeros the LO Q circuit.

4.3.4 Δ Q VOLTMETER CIRCUIT.

The circuit is electrically similar to those already described, except that zero on the Δ Q scale is at the full-scale position of the meter needle. This is necessary because adding a component to a circuit lowers the circuit Q.

Both coarse and fine Δ Q balancing adjustments are provided, R-204 and R-205, respectively. The bucking voltage obtained from these controls is applied not only to the grid of one of the 12AT7 triode sections, but to the midpoint of the two cathodes as well, permitting more linear operation as a differential voltmeter. Once the operating level is set, by adjusting the Δ Q balancing controls, any reduction in the voltage from the signal diode, V103, causes an unbalance which is indicated as a lower meter reading. R-214 is the calibrating potentiometer for this circuit function and R-218 the meter multiplier resistor.

4.4 POWER SUPPLY.

In the Model 190-A Q Meter, power is fed into VR-300, a saturable reactor, which holds the voltage within narrow limits under widely-fluctuating voltage conditions on the external 60 cps supply line. Transformer T-300 feeds the tube filaments, providing a separate winding for the 9005 diodes.

Resistor R-300 limits current to the selenium rectifiers, CR-300 and CR-301, in the voltage doubler, which employs capacitor-input (pi-section) filtering. The voltage reference tube, V-300, a type 0B2, maintains a constant d-c voltage for the measuring circuit potentiometers and the d-c meter amplifier. A d-c voltage is tapped off directly at the filter output to supply the SET XQ control, which feeds the oscillator plates.

The Model 190-AP Q Meter, which must be used for 50 cps operation, employs the same power supply circuit, except that a 1:1 transformer is provided in place of the saturable reactor, VR-300. Therefore, external voltage regulation ahead of the power supply is recommended.

SECTION V

5. HIGH FREQUENCY ERRORS AND CORRECTIONS.

5.1 GENERAL.

Although every effort has been made to reduce sources of error in the Q Meter Type 190-A to a minimum it is impossible to eliminate them completely.

In the majority of Q Meter measurements high accuracy is not required and the correction of errors is not necessary, however, it is desirable to study the sources of error in order to avoid them where ever possible and to indicate how approximate corrections can be made when desired.

The following are the major sources of error:

1. Improper placement of the component being measured.
2. Voltmeter errors at high frequency.
3. Errors due to residual impedances internal to the Q Meter.

5.2 PLACEMENT OF COMPONENTS.

The location of the component being measured with respect to surrounding objects is always important, particularly at high frequencies. However, the component will eventually be mounted in a circuit in close proximity to a chassis so that it may be desirable to place it on the Q Meter in a similar position with respect to the top of the instrument. A few examples will illustrate the importance of component placement.

5.2.1 A 121,000 ohm type MPM resistor with 1" leads was mounted horizontally with leads placed vertical to HI and GND binding posts. It measured 113,000 ohms at 30 mc by the parallel method.

When the resistor was bent down so that it was spaced $\frac{1}{8}$ " from the top of the instrument, it measured 96,500 ohms. Finally the resistor was encased in a brass shield $\frac{1}{4}$ " in inner diameter and 1" long with the shield connected to the grounded terminal of the resistor. It now measured 61,700 ohms and the position of the shielded resistor had negligible effect. This illustrates the effect of variations in the distributed capacitance of the resistor to ground.

5.2.2. The effect of coupling between an unshielded working coil and a component being measured by the parallel method was checked as follows:

The inductor was a 1" diameter loop connected to the COIL terminals of the Q Meter. A resistor with 1" leads was formed into a loop 1" in diameter and was mounted on the HI and GND CAP binding posts 1" distant from and parallel to the unshielded inductor. The resistor measured 39,700 ohms at 85 mc. The coil connections were then interchanged to reverse the voltage induced in the resistor loop. The resistor now measured 35,200 ohms, a difference of about 12%.

Obviously shielded inductors should be used or the component should be placed so as to minimize the coupling between it and the inductor.

5.2.3 The importance of lead length can be illustrated by noting that the lead inductance of a capacitor will make the effective value of the capacitance at high frequencies (C_e) greater than the low frequency value (C) in accordance with the formula

$$C_e = \frac{C}{1 - \omega^2 LC} \quad (5-1)$$

where L = the inductance of the leads of the capacitor.

The following measurements were made on a tubular ceramic capacitor $\frac{3}{8}$ " long.

F	Lead Length	C_e	L
150 mc	1"	14.9 $\mu\mu\text{f}$.044 μh
150	$\frac{1}{2}$ "	11.8	.024
150	$\frac{1}{4}$ "	10.9	.016
20	$\frac{1}{4}$ "	9.4	

These examples illustrate that the operator must exercise considerable care in the placement of components on the instrument if the most useful and consistent measurements are to be obtained.

5.3 VOLTMETER ERRORS AT HIGH FREQUENCY.

The Q and XQ voltmeters suffer from the usual type of high frequency errors. Due to approaching resonance of the inductance of the voltmeter leads with

the diode plate to cathode capacitance, the voltage across the diode elements is stepped up so that the indicated voltages will be higher than the true values. The resonant frequency of each voltmeter circuit is about 850 megacycles so that both meters will indicate about 9% high at 250 mc from this cause, however, since only the ratio of the readings is involved the error cancels and no correction is necessary.

A more annoying error is that due to electron transit time in the voltmeter diodes. Since this error is a function of voltage level as well as frequency, it does not cancel completely except when the circuit Q is 100 under which condition the same voltage appears across both diodes.

The error can be calculated and corrections are shown in Figure V-1.

The corrected circuit Q is found from the equation

$$Q \text{ corrected} = \frac{(\text{Factor for Q Voltmeter})}{(\text{Factor for XQ Voltmeter})} \times (Q \text{ indicated}) \quad (5-2)$$

For example, at a frequency of 200 mc and a XQ reading of 1, the "Factor for XQ Voltmeter" is 1.09 and if the Q reading is 200, the "Factor for Q Voltmeter" is 1.065 and the corrected Q is:

$$Q \text{ corrected} = \frac{1.065}{1.09} \times 200 = 195.5$$

a correction of -2.25%.

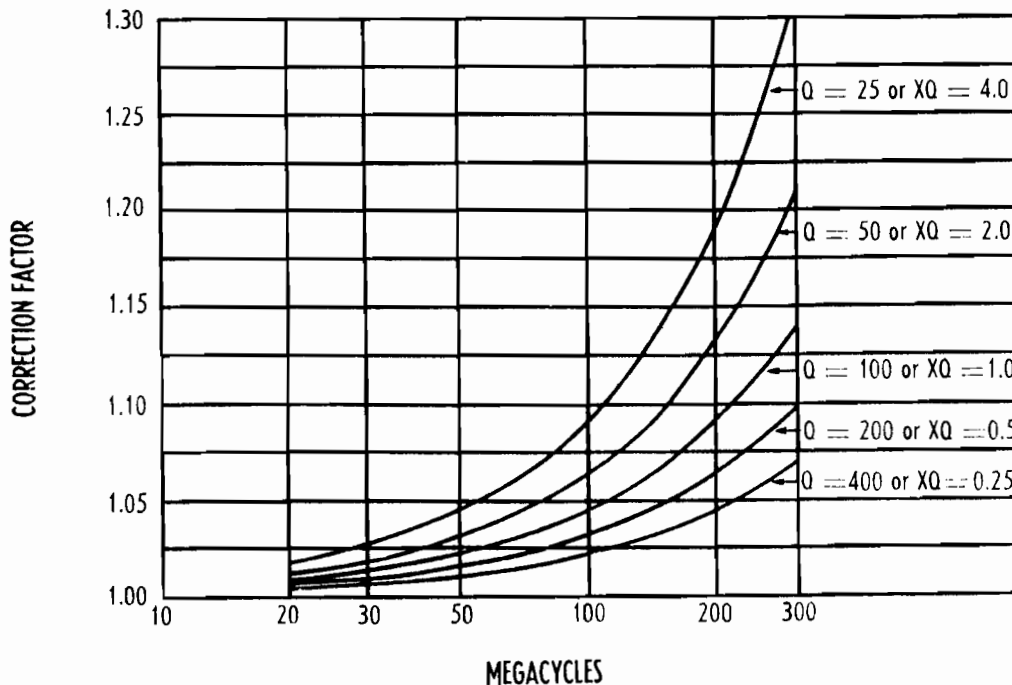

FIG. V-1 CORRECTION FOR VOLTMETER TRANSIT TIME ERROR

5.4 ERRORS DUE TO RESIDUAL IMPEDANCES INTERNAL TO THE Q METER.

It is obviously impossible to completely eliminate inductance and resistance in the Q measuring circuit. These "residual impedances" will cause errors which in general increase with frequency and for which it is sometimes desirable to make approximate corrections.

5.4.1. CIRCUIT INCLUDING RESIDUALS.

Figure V-2 shows the Q measuring circuit with the residual impedances included. These residuals are quite small and difficult to measure, furthermore, they differ between individual Q Meters. The values given below are representative and will enable approximate corrections to be made.

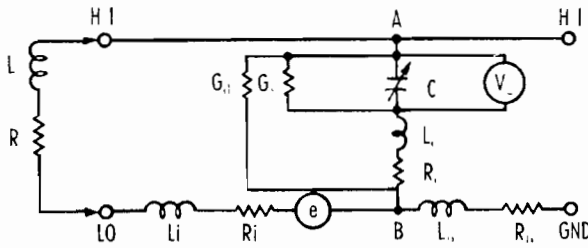

FIG. V-2 CIRCUIT INCLUDING RESIDUALS

5.4.2 Approximate Values of Residuals: (Figure V-2)

- $L_c \approx 0.0014 \mu h =$ inductance of Q capacitor contact fingers.
- $R_c \approx 0.0004 \sqrt{F_{mc}} =$ resistance in ohms of L_c .
 $F_{mc} =$ frequency expressed in megacycles.
- $L_i \approx 0.0012 \mu h =$ inductance of coil LO and HI binding posts and coupling impedance across which injection voltage appears.
- $R_i \approx 0.0008 \sqrt{F_{mc}} =$ resistance in ohms of L_i .
- $L_b \approx 0.001 \mu h =$ inductance of CAP HI and GND binding posts.
- $R_b \approx 0.0003 \sqrt{F_{mc}} =$ resistance of L_b .
- $G_D \approx 0.0167 F_{mc} \mu mho =$ conductance of steatite Q condenser stator support.
- $G_V \approx 0.0167 F_{mc} \mu mho =$ conductance of Q voltmeter.

The conductance G_V is greater than the value given by this equation at low and high frequency. More accurate values are given in Figure V-3.

5.4.3 Effect of Equivalent Series Residuals.

To find the equivalent series residuals, the circuit of Figure V-2 can be reduced to the circuit of Figure V-4.

To find the value of the external inductance, L, the internal inductances L_c and L_i must be subtracted from the total inductance L_s found from Equation 5-3 in-

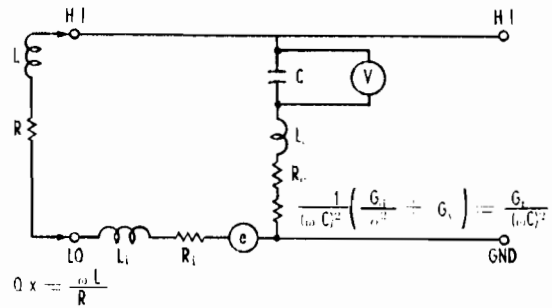

$$0 x = \frac{\omega L}{R}$$

$$(5-4) R_c = \frac{1}{\omega C Q} = R \left[R_i + R_c + \frac{1}{(\omega C)^2} \left(\frac{G_D}{\alpha^2} + G_V \right) \right]$$

$$(5-4a) \frac{1}{\omega C Q} = R \left[R_i + R_c + \frac{G_V}{(\omega C)^2} \right]$$

$$(5-3) L_s \frac{1}{\omega C} = L_s + (L_c + L_i)$$

FIG. V-4 EQUIVALENT SERIES CIRCUIT

cluded in Figure V-4. Since $(L_i + L_c)$ is only 0.0026 μh this correction is generally negligible.

To find the series resistance of the unknown, R, the internal resistance must be subtracted from the total circuit resistance found from Equation (5-4) included in Figure V-4.

The term $\frac{1}{(\omega C)^2} \left(\frac{G_D}{\alpha^2} + G_V \right)$ in Equation 5-4, due to internal shunt losses, varies with the capacitance setting of the Q-condenser, C. When C is large, this term is small compared with $R_i + R_c$. When C is small, this term is large compared with $R_i + R_c$.

α is defined by Equation (5-5) which appears together with graphical values of α on Figure V-5. It represents the magnification of the effective value of C due to the inductance L_c . Since α is significantly greater than 1, only when C is large and the whole term $\frac{1}{(\omega C)^2} \left(\frac{G_D}{\alpha^2} + G_V \right)$ is then negligible, it is generally sufficiently accurate to use the approximate expression

$\frac{G_V}{(\omega C)^2}$ (Equation 5-4a). An exception to this is when low impedances are measured by inserting them in series with the working coil L, R, in which case it may be necessary to use the exact form (Equation 5-4).

5.4.3.1 Example of Method of Correcting for Series Residuals.

The following is an example of the method of correcting the readings obtained on a small inductor in order to find the most accurate values of effective L and Q.

Q Meter Readings				Calculate	
F	C	Q	XQ	ω	$1/\omega C$
150 mc	30 $\mu\mu f$	250	1	9.42×10^5	35.3 Ω

Transit time correction (Equation 5-2, Figure V-1).

$$(\text{Circuit } Q = \frac{1.06}{1.085} \times 250 = 244$$

MODEL 190-A Q METER

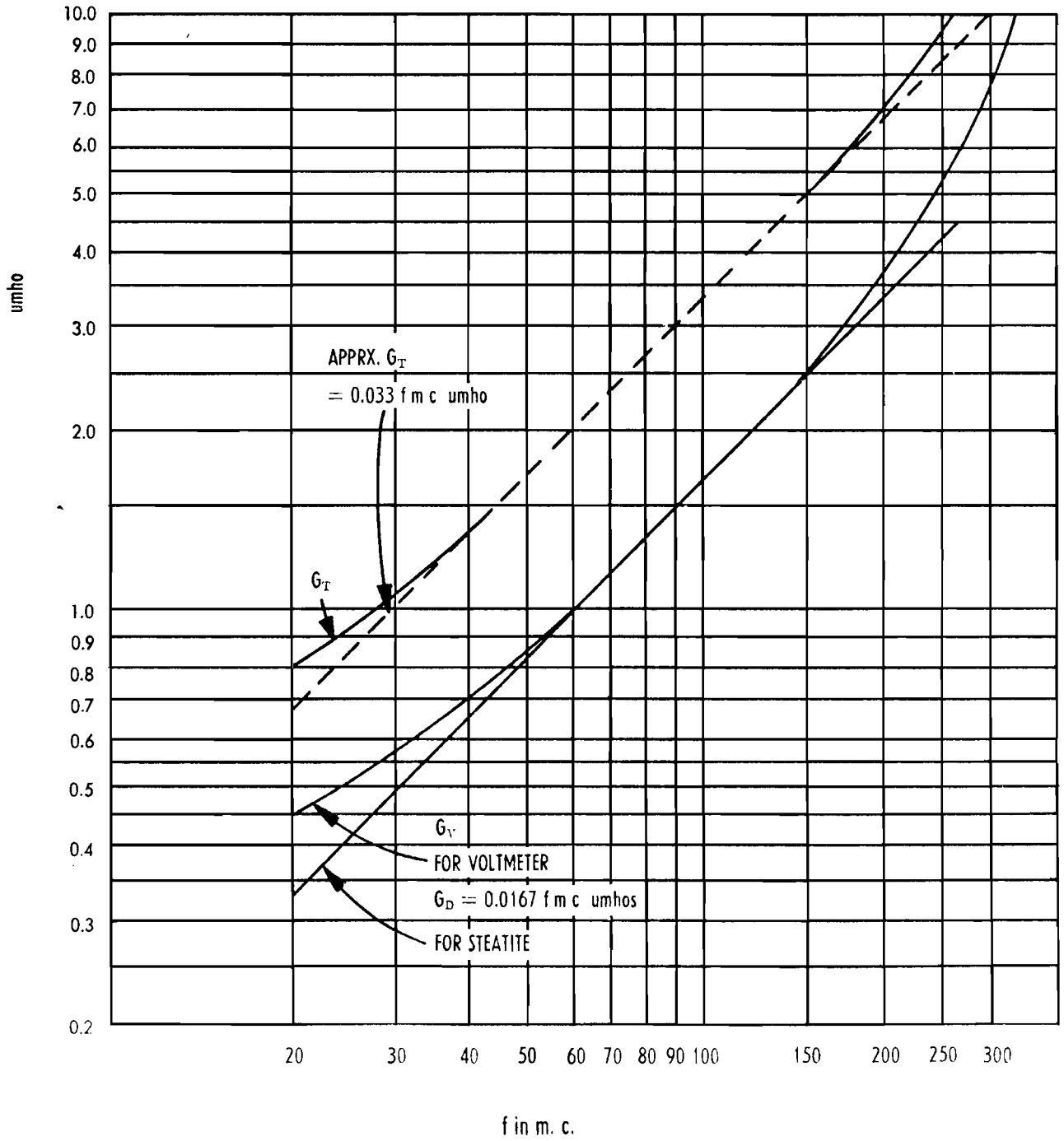

Fig. V-3 Internal Conductances

Total inductance (Equation 5-3, Figure V-4).

$$L_s = \frac{1}{\omega} \cdot \frac{1}{\omega C} = \frac{1}{9.42 \times 10^7} \times 35.3 = 0.0375 \mu\text{h}$$

$$L = L_s - (L_i + L_c) = 0.0375 - 0.0028 = 0.0347 \mu\text{h} \quad (5-3)$$

A correction of -8%.

Total series resistance (Equation 5-4a).

$$R_s = \frac{1}{\omega C} \cdot \frac{1}{Q} = \frac{35.3}{244} = 0.145 \Omega$$

$$R_i + R_c = (0.0008 + 0.0004)\sqrt{150} = 0.0147$$

$$\frac{G_T}{(\sqrt{W}G)^2} = (35.3)^2 \times 5 \times 10^{-6} = 0.0062$$

(G_T from Figure 5-3)

Adding, the internal series resistance = 0.0209 Ω

$$R = 0.145 + 0.021 = 0.166 \text{ ohm}$$

A correction of -14.5%.

The effective $Q = \frac{\omega L}{R}$

$$= \frac{9.42 \times 10^7 \times 0.0347 \times 10^{-6}}{0.124}$$

This indicates the indicated Q by +5%.

5.4.4 Effect of Residuals on Parallel Measurements.

For the purpose of an analysis of parallel measurements, it is convenient to convert the series elements between points A-B of Figure V-2 into equivalent parallel elements and to use Thevenin's theorem to convert the circuit to the left of points A-B to an equivalent constant current source. The result is shown in Figure V-6, where L' and G' represent the equivalent conductance and parallel inductance of $R + R_i$ and $L + L_i$ respectively. The constant current I is given by:

$$I = \frac{e}{(R + R_i) + j\omega(L + L_i)} \approx \frac{e}{\omega(L + L_i)} = e\omega C_1\alpha_1 \quad (5-6)$$

The approximation is accurate to better than 1% if the Q of the working inductor is greater than 10.

From the equivalent circuit of Figure V-6, it is easily shown that, for a capacitive unknown, its equivalent parallel capacitance is given by:

$$C_p = C_1\alpha_1 - C_2\alpha_2 \quad (5-7)$$

Where the subscripts 2 and 1 refer to the values with the unknown connected and disconnected respectively. If C_2 is greater than C_1 , the unknown is inductive and:

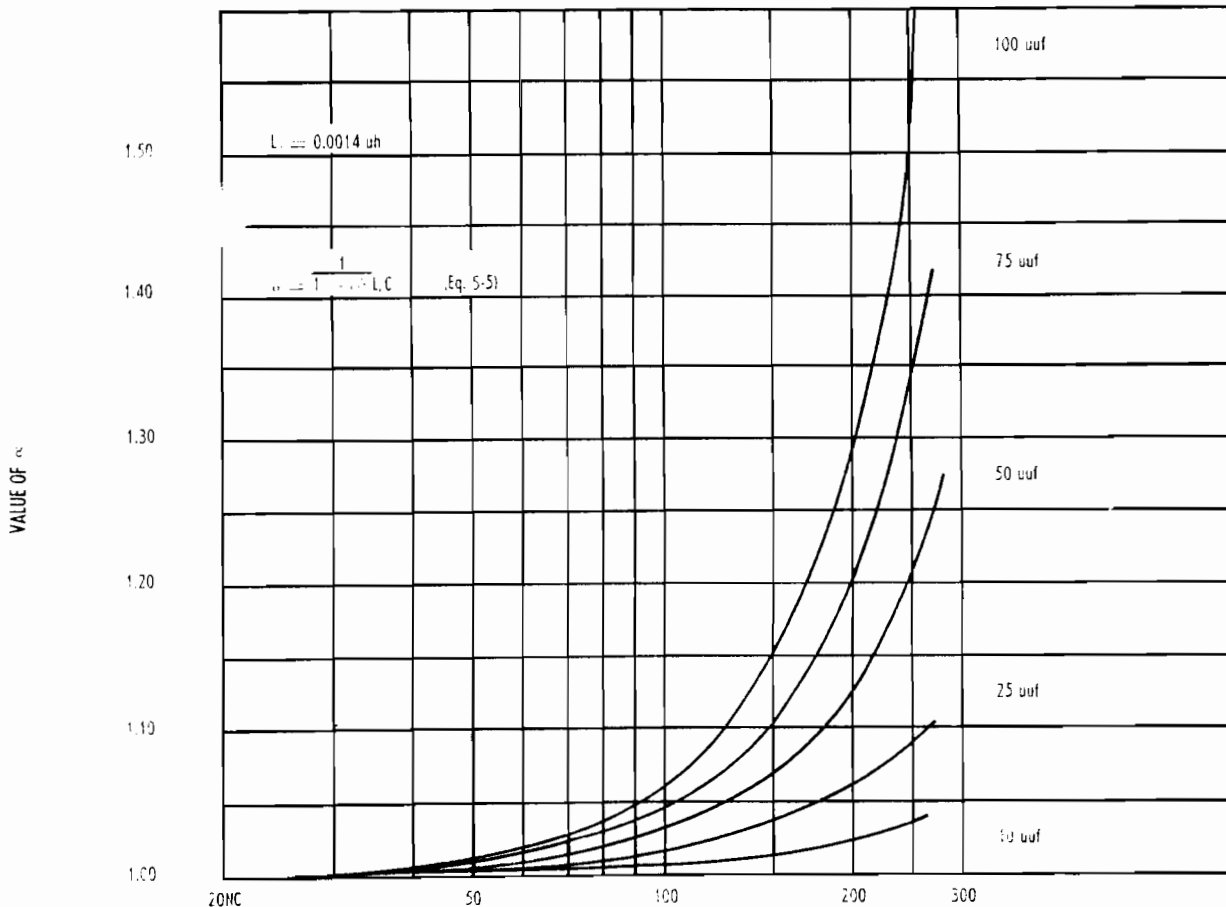

Fig. V-5 - As a Function of Frequency in Megacycles

$$L_p = \frac{1}{\omega^2(C_2\alpha_2 - C_1\alpha_1)} \quad (5-8)$$

The conductance of the unknown is given by:

$$G_x = \omega C_1 \alpha_1 \left(\frac{\alpha_2}{Q_2} - \frac{\alpha_1}{Q_1} \right) + R_c \omega^2 (\overline{C_1 \alpha_1}^2 - \overline{C_2 \alpha_2}^2) + G_V (\alpha_1^2 - \alpha_2^2) \quad (5-9)$$

The first term on the right is equivalent to Equation (5 Table III-1A) except for the α 's which are due to the "tapping down" of the unknown on the circuit because of the inductance of the contacting fingers L_c .

The term in brackets is due to the change in the losses in R_c and G_V due to variations in C . This term disappears if the unknown is a pure resistance and $C_1 = C_2$. It is negative for an inductive unknown.

The HI and GND binding post residuals are charged to the unknown and it may be necessary to correct for them. The inductance, L_B , will generally be small compared with the lead inductance of the unknown and correction for it is seldom necessary. If the unknown has a very high Q, correction should be made for R_B as illustrated in the following example.

5.4.4.1 EXAMPLE OF PARALLEL MEASUREMENT.

The method of correcting the measurements of a small capacitor is given below:

Q Meter Reading					
F	C_1	Q_1	C_2	Q_2	XQ
150 mc	23.25	307	13.1	259	1

From Figure V-5:

Calculate:

α_1	α_2	ω	$C_1\alpha_1$	$C_2\alpha_2$
1.03	1.025	9.42×10^5	23.95	13.43

Transit Time Correction:

$$\text{Corrected } Q_1 = \frac{1.05}{1.085} \times 307 = 297$$

$$\text{Corrected } Q_2 = \frac{1.06}{1.085} \times 259 = 253$$

$$\text{Equation 5-7: } C_p = 23.95 - 13.43 = 10.52 \mu\mu f$$

This differs by +3.5% from the uncorrected value $C_1 - C_2 = 10.15$

G_x correction terms from equation 5-9:

$$G_V (\alpha_1^2 - \alpha_2^2) = 2.5 \times 10^{-6} (1.03^2 - 1.025^2) = 0.025 \times 10^{-6}$$

$$R_c \omega^2 (\overline{C_1 \alpha_1}^2 - \overline{C_2 \alpha_2}^2) = 0.0004 \sqrt{150} \times (9.42 \times 10^5)^2 (23.95^2 - 13.43^2) \times 10^{-24} = 0.017 \times 10^{-6}$$

Adding,
Total correction = $4.2 \times 10^{-8} = 0.042 \times 10^{-6}$

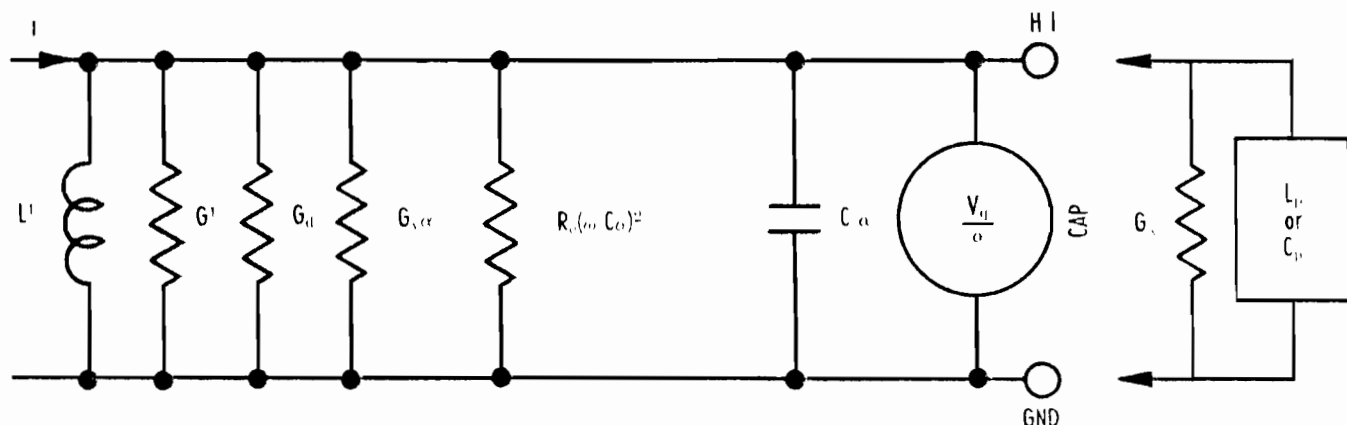

C = CAPACITOR DIAL READING

$$C_p = C_1 \alpha_1 - C_2 \alpha_2 \quad (6-7)$$

$$L_p = \frac{1}{\omega^2 (C_2 \alpha_2 - C_1 \alpha_1)} \quad (6-8)$$

$$G_x = \omega C_1 \alpha_1 \left(\frac{\alpha_2}{Q_2} - \frac{\alpha_1}{Q_1} \right) + \left[R_c \omega^2 (\overline{C_1 \alpha_1}^2 - \overline{C_2 \alpha_2}^2) + G_V (\alpha_1^2 - \alpha_2^2) \right] \quad (6-9)$$

$$Q_x = \frac{\omega C_p}{G_x} = \frac{1}{G_x \omega L_p} \quad (6-10)$$

Fig. V-6 Equivalent Parallel Circuit

Principal term,

$$\begin{aligned} \omega C_p \alpha_1 \left(\frac{\alpha_2}{Q_2} - \frac{\alpha_1}{Q_1} \right) &= 9.42 \times 10^8 \times 23.95 \\ &\times 10^{-12} \left(\frac{1.025}{253} - \frac{1.03}{297} \right) \\ &= 13.15 \times 10^{-6} \end{aligned}$$

Then

$$G_x = 13.15 \times 10^{-6} + 0.042 \times 10^{-6} = 13.19 \times 10^{-6}$$

In this case the correction term in brackets was negligible.

The correction for R_B is made by finding the equivalent lead conductance and subtracting this from G_x .

$$\begin{aligned} G_B &= R_B (\omega C_x)^2 \\ &= 0.0003 \sqrt{150} (9.42 \times 10^8 \times 10.5 \times 10^{-12})^2 \\ &= .359 \times 10^{-6} \end{aligned}$$

$$\text{Corrected } G_x = 13.19 - 0.36 = 12.83$$

The Q of the unknown condenser is:

$$Q_x = \frac{\omega C_p}{G_x} = \frac{9.42 \times 10^8 \times 10.5 \times 10^{-12}}{12.83 \times 10^{-6}} = 771$$

Using Equation 4 in Table III-1-a without any corrections yields:

$$Q_x = 724, \text{ an error of } -6\%.$$

SECTION VI MAINTENANCE

6.1 GENERAL.

6.1.1 Because the BRC Type 190-A Q Meter is a precision-built, factory-calibrated instrument, field maintenance of the equipment must be limited to certain practical operations if the accuracy of the instrument is to be retained. This is necessary because, in the field, certain laboratory test equipment and specially-constructed calibrating instruments are generally unavailable.

NOTE:

It is recommended that careful measurements be made, using a set of Boonton Radio Corp. Type 590-A inductors, as soon as the 190-A is placed in operation. The data may be filed as a reference standard for the individual Q Meter so that it will be available for comparison should calibration or other maintenance work on the instrument become necessary. At least one measurement of the appropriate Type 590-A inductor should be made near each end of each frequency band on the Q Meter, except that no measurement need be made near 20 or 260 mc.

6.1.2 It is the policy of the company to make available to its customers such service as is needed to maintain its product within specifications, as advertised, at a reasonable cost. If the accuracies of the Q Meter appear

to be impaired it is recommended that the instrument be returned to the factory. Maintenance operation beyond the scope of this section should be referred to the factory. Some of the specific troubles requiring factory attention are listed in the following paragraphs.

6.1.3 Factory Repair Operations.

Repair, adjustment or replacement of the items listed below require that the equipment be returned to the factory.

- a. Oscillator coils (Figure VI-1).
- b. Oscillator turret assembly (Figure VI-1).
- c. Q Capacitor (Figure VI-1).
- d. Transmission line.

6.2 REMOVING THE INSTRUMENT FROM ITS CABINET.

Removal of the instrument from its cabinet is a simple procedure, but it must be done with care.

Remove the nine screws at the two sides and bottom of the front panel, and the seven screws at the two sides and back of the top panel. The entire unit, including the top and front panels may now be lifted off, carefully turned over and placed on the bench. Access to the power supply may be obtained by removing the eight screws and ground post from the rear panel and removing the panel.

A cable terminated in an octal plug and a pair of generously long leads for the on-off power switch are the sole means of interconnection between the measuring circuits on the front panel and the power supply at the rear of the cabinet.

6.3 REPLACEMENT OF TUBES.

6.3.1 GENERAL.

Any of the six electron tubes in the Type 190-A Q Meter can be replaced with unselected tubes with the exception of the Q voltmeter diode (V-103, type 9005). If replacement of this tube becomes necessary a selected one should be obtained from the manufacturer.

When any tube, except the voltage reference tube (V-300, type OB2) is replaced, recalibration is required to maintain full accuracy of the instrument. The procedures are described in this section. All components mentioned here are shown in Figures VI-2 and VI-3.

6.3.2 Replacement of Oscillator Tubes V-100 and/or V-101 (Type 5718).

a. Remove the four screws (Figure VI-2) holding the oscillator cover plate in place, and remove the oscillator cover plate.

b. Unsolder the tube leads. The exact arrangement of these leads is shown in Figure 6-4.

c. Carefully lift the tube(s) out of the oscillator compartment.

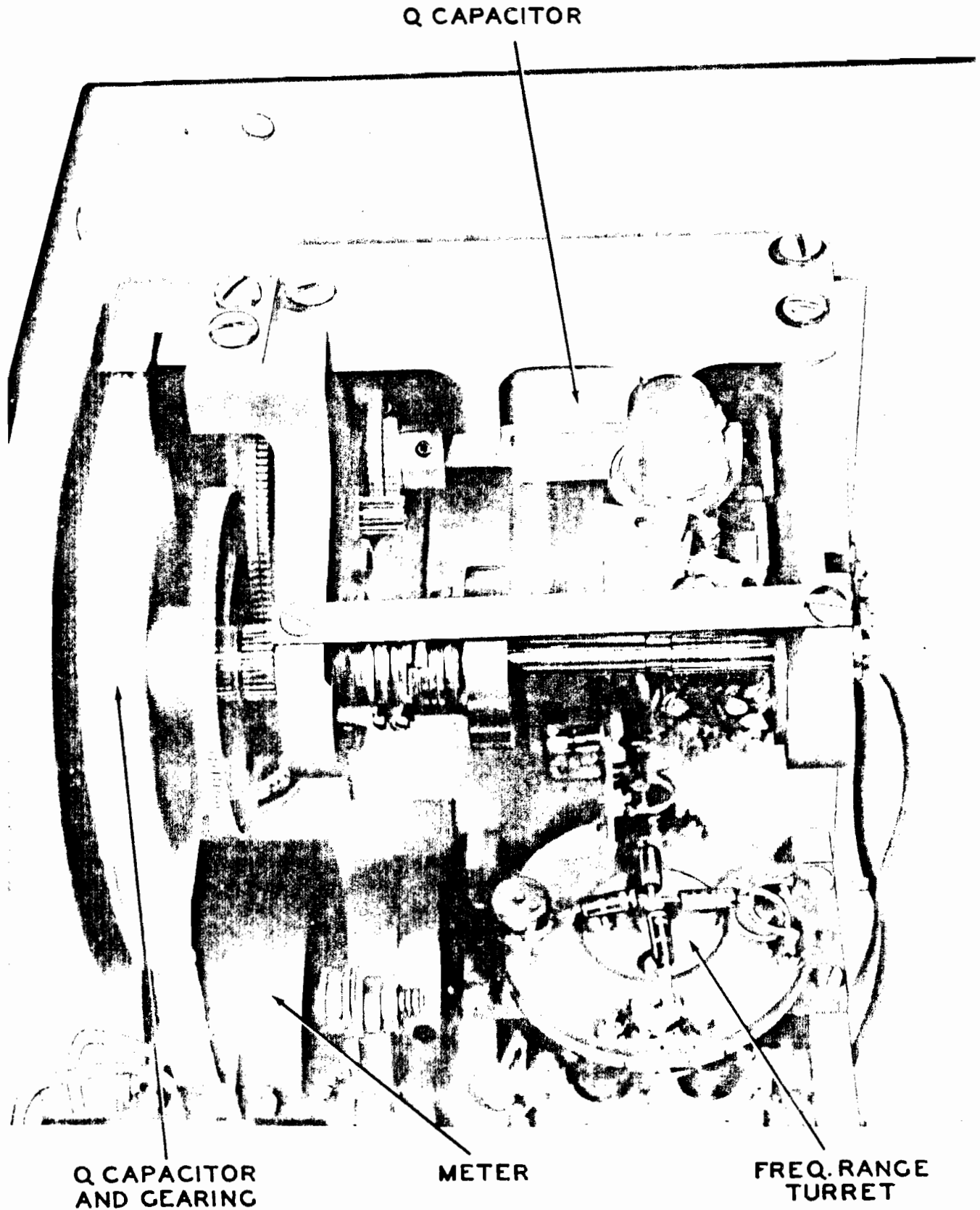

FIG. VI-1 Q CAPACITOR AND OSCILLATOR TURRET

d. Replace with new tubes and resolder all connections. Make sure the new tubes are oriented in the same manner as those removed and that the leads are as short as possible. Use as little solder as possible, and avoid cold-soldered joints.

e. Replace the oscillator cover plate and four screws.

f. Check the frequency dial calibration as described in 6.4.2.

6.3.3 Replacement of Voltmeter Tubes V-102 and/or V-103 (Type 9005).

a. Unsolder the leads connected to the pins around the periphery of tubes V-102 and/or V-103 (9005's) shown in Figure VI-2 and remove the tube(s) from their supporting brackets.

b. Replace with new tubes (in the case of V-103 a selected tube secured from the manufacturer) and resolder all connections. Make sure the new tubes are oriented in the same manner as those removed. Use as little solder as possible and avoid cold-soldered joints. Make all leads as short as possible.

c. Check the voltmeter calibration as described in 6.4.3.

6.3.4 Replacement of Amplifier Tube V-200 (Type 12AT7):

a. Remove the shield cover and pull out the tube (Figure VI-3); replacing it with an appropriate substitute.

b. Check the amplifier balance as described in 6.4.1.

6.3.5 Replacement of Voltage Regulator Tube Type V-300.

To remove tube V-300 (OB2) shown in Figure VI-5, remove the nine screws attaching the back plate to the cabinet; remove the back plate. Remove the tube shield, pull out the tube and replace it. No recalibration is required when this tube is replaced.

6.4 ADJUSTMENTS AND CALIBRATIONS.

6.4.1 D-C Amplifier Balance Adjustment (R-208 Setting).

The d-c amplifier balance potentiometer, R-208 (Figure VI-2) should be adjusted as follows when tube V-200, 12AT7, is changed.

a. Allow the equipment to warm up for ten minutes.

b. Locate resistors R-206 and R-210, the second and third resistors from the front (looking from the rear toward the front of the instrument) on the resistor board just above the calibrating potentiometer panel (Figure VI-3). Strap together the lugs at the ends of

these two resistors which are *nearest the tube* (V-200). This connects the two grids together.

c. Turn the SET XQ knob fully counterclockwise to decrease the oscillator output to zero.

d. Adjust potentiometer R-208 (left-hand shaft with rear of instrument facing observer) (Figure VI-2) for a zero meter indication. If the balance condition is beyond the range of the potentiometer, the tube sections are too unbalanced for use in the instrument. Replace with another 12AT7 tube.

e. Remove the strap between resistors R-206 and R-210.

6.4.2 Oscillator Calibration (C-103 Adjustment).

When either or both of the type 5718 oscillator tubes (V-100 and V-101) are changed, it is necessary to check the frequency. Such a tube change affects only the capacitance of the circuit, so recalibration is necessary on only one frequency band.

A crystal calibrator with a 10 mc crystal is required for this calibration.

To calibrate the oscillator, proceed as follows:

a. Remove the instrument from its cabinet.

b. Turn on the 190-A and allow it to warm up fully.

c. Connect the RF INPUT terminals of the crystal calibrator to the LO and GND terminals on top of the 190-A.

d. Set the crystal calibrator to 10 mc.

e. Turn the FREQ. RANGE switch on the 190-A to the second range (40-80 mc). Set the MC DIAL to exactly 80 mc.

f. Adjust the SET XQ control on the Q Meter to 1 on the XQ scale, with the XQ key operated.

g. Slowly adjust trimmer capacitor C-103 (Figure 6-2) until a zero beat is obtained.

6.4.3 Calibration of Voltmeter Scales.

When either of the diodes, V-102 or V-103, is replaced, the voltmeter scales should be recalibrated to maintain maximum accuracy.

The following equipment is required:

A 100 kc signal source, delivering up to 4 volts with no more than 1% distortion. The voltmeter bypassing is insufficient to use lower frequencies. If the 100 kc signal source does not have a d-c resistance less than 10 k ohms, shunt it with a 10 k ohm resistor.

AC vacuum-tube voltmeter, 0.01-100 volts, accuracy $\pm 1\%$ at 100 kc over the entire scale.

The test circuit to be used is illustrated in Figure VI-6. The procedure is as follows:

General:

a. Adjust the mechanical zero of the meter before the power is turned on.

MODEL 190-A Q METER

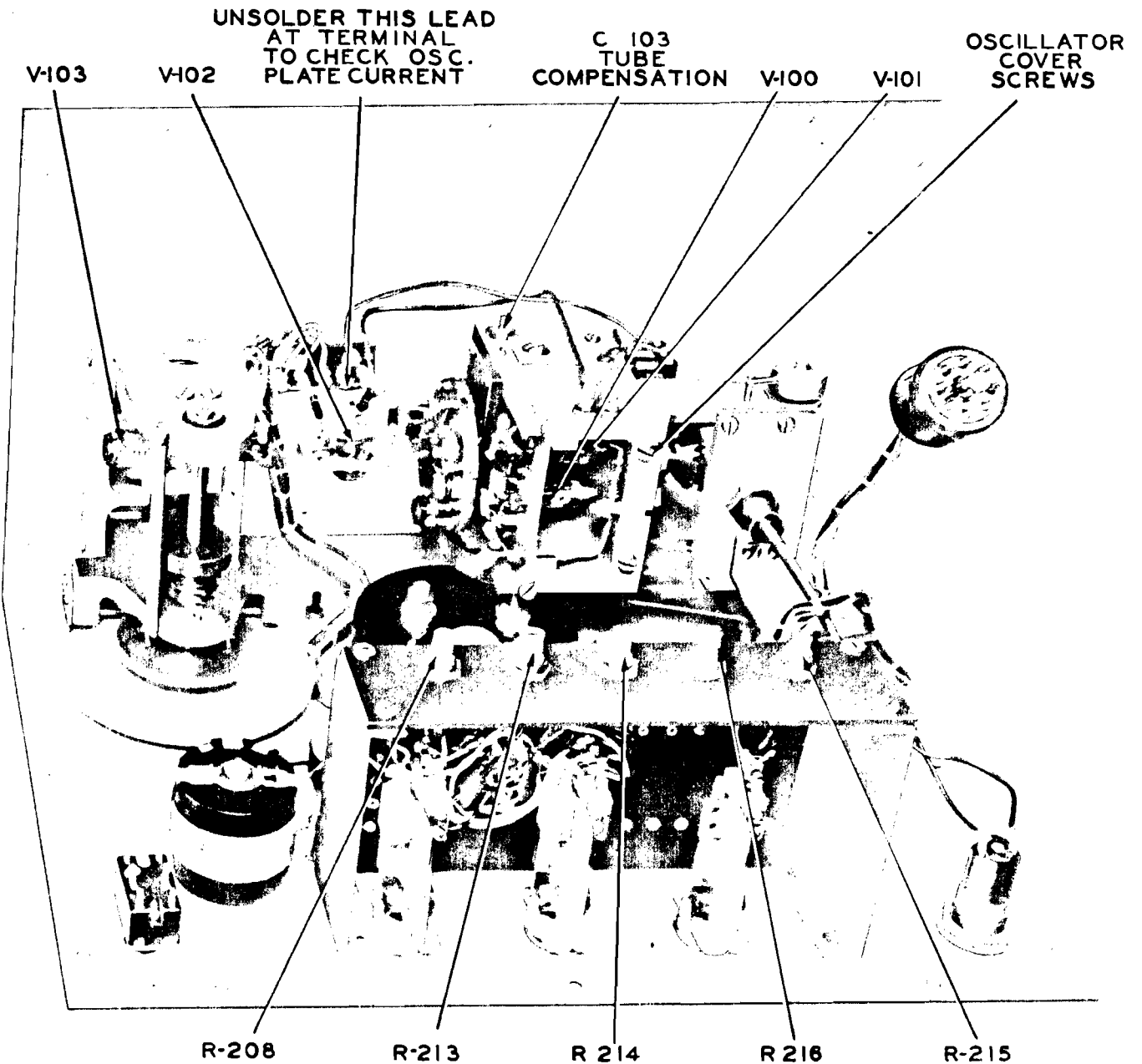

FIG. VI-2 REAR VIEW OF Q METER

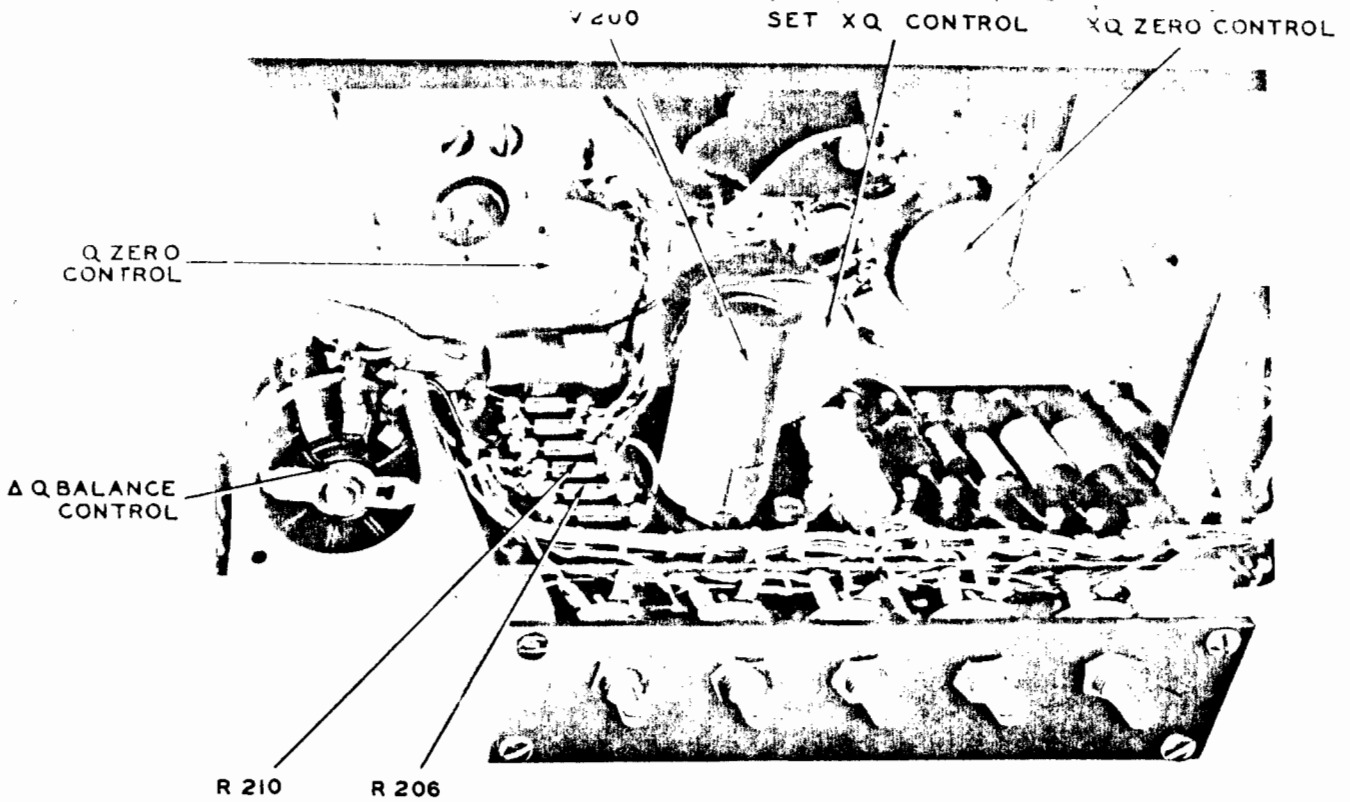

FIG. VI-3 VOLTMETER CHASSIS

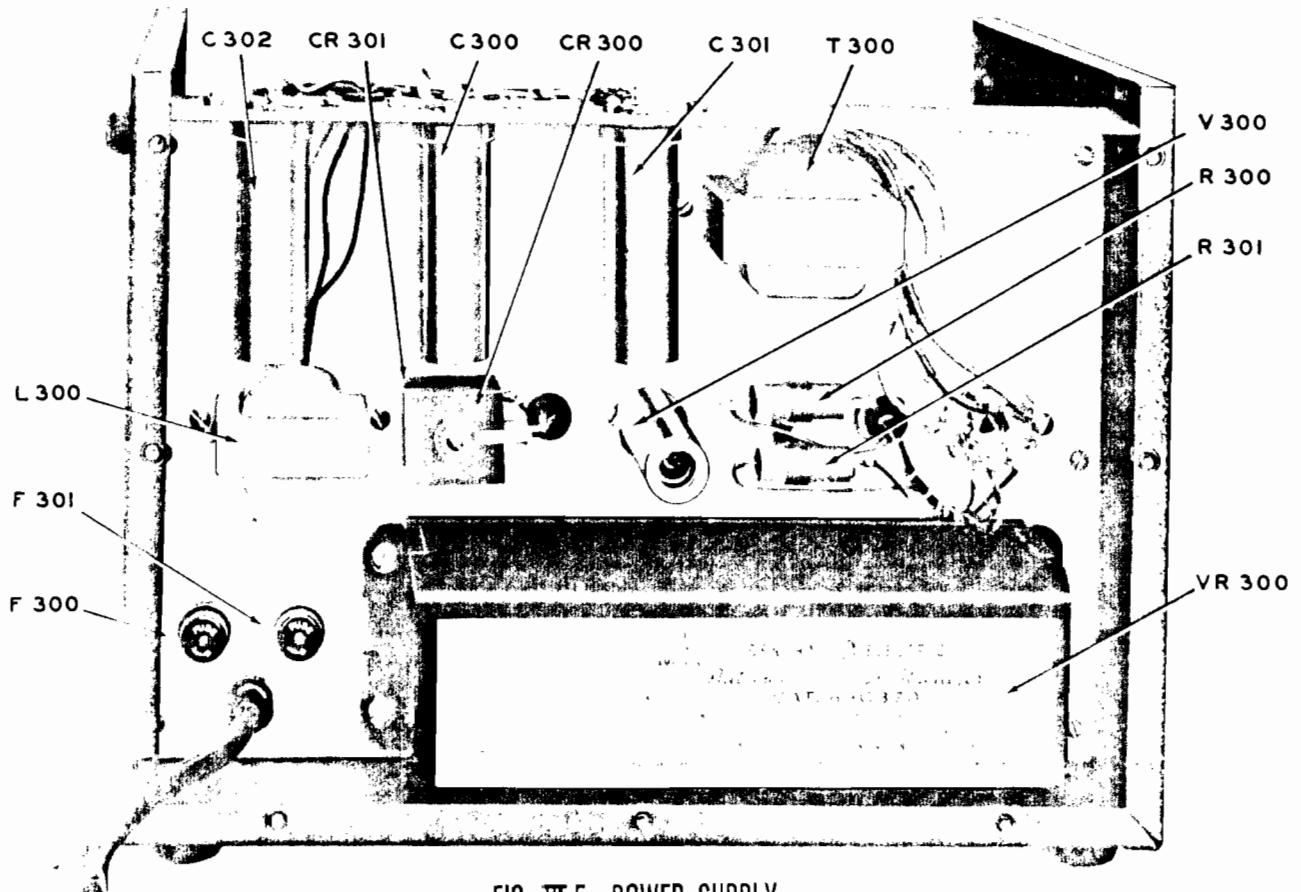

FIG. VI-5 POWER SUPPLY

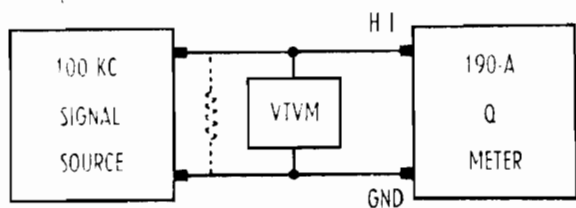

FIG. VI-6 TEST CIRCUIT FOR CALIBRATION OF VOLTMETER SCALES

supply connecting plug and ground. If all are within the limits specified below, the power supply is operating properly.

TEST	MEASURED AT	VALUE	TOLERANCE
Regulated dc voltage	Pin 8	107 v dc	$\pm 1v$
High dc voltage	Pin 7	200 v dc	$\pm 10v$
Ripple on high dc	Pin 7	50 mv ac, max.	
Diode fil. voltage	Pin 3	6.0 v ac	$\pm 0.6v$
Other fil. voltage	Pin 1	6.3 v ac	$\pm 0.6v$

Instruments Required:

DC voltmeter, 0-250 volts, $\pm 2\%$, 1000 ohm v or more.

AC vacuum tube voltmeter, 0.01-100 volts $\pm 2\%$.

6.6 TROUBLE SHOOTING.

General:

Due to the electrical simplicity of its circuitry, trouble shooting the Model 190-A is normally a straight-forward operation. The use of conventional continuity-checking methods, employing an ohmmeter and referring to the schematic diagram (Figure IV-2), usually will reveal the source of the trouble.

A few of the troubles which might occur are given below, in terms of external operating symptoms together with the probable cause of the trouble. It should not be overlooked, however, that in addition to possible causes given in the chart, any of the troubles listed might be due to defective resistors, capacitors or other electrical components.

TROUBLE SHOOTING CHART

Symptom	Possible Cause
No meter indication of any kind.	V-200 (12AT7) d-c voltmeter amplifier faulty. Switch failure (panel spring retained) Meter failure.
No meter indication other than that caused by varying the Q zero, XQ zero, and ΔQ balance controls.	V-200 (12AT7) d-c voltmeter amplifier faulty. V-102 and/or V-103 (9005) XQ and Q diodes faulty. V-100 and/or V-101 (5718) oscillator tubes faulty. Oscillator coil open.
Impossible to set zero properly with Q zero or XQ zero controls. No Q reading, but XQ reading satisfactory.	V-200 (12AT7) d-c voltmeter amplifier faulty. Q voltmeter diode inoperative. Q capacitor (or circuitry) shorted. Transmission line open (return to factory). Switch failure.
No XQ reading, but Q reading satisfactory.	V-102 (9005) XQ diode faulty. Switch failure.
Impossible to obtain full-scale reading (0.5) on XQ scale over frequency range, with XQ control advanced to maximum position.	V-100 and/or V-101 (5718) oscillator tube(s) faulty. Oscillator coil open.
Irregular or erratic readings on Q, XQ, LO Q, and/or ΔQ scales.	Dirty contacts or loose wipers on potentiometers or key switches. If this occurs on all scales, suspect R-208 plus any of those listed below.
If above occurs on Q scale only.	Check R-202 (Q Zero), R-215, (Q cal.), S-200, S-201, S-202.
If above occurs on XQ scale only.	Check R-200 (XQ zero), R-216, (XQ cal.), R-223 (SET XQ), S-200, S-201, S-202.
If above occurs on ΔQ scale only.	Check R-204 (coarse, ΔQ BALANCE) R-205 (fine ΔQ BALANCE), R-214. (ΔQ cal.), S-201, S-202.
If above occurs on LO Q scale only.	Eliminate S-200, S-201, and R-215 from suspicion; for Q scale, above, plus check all other items listed R-213 (LO Q cal.).

MODEL 190-A Q METER

ELECTRICAL COMPONENTS

R-F SECTION

Circuit Symbol	Value	Description	BRC Part No.
C-100	0.001 μ f	Capacitor, fixed: $\pm 10\%$; 500V	82310
C-101,C-102	5 μ μ f	Capacitor, fixed: ± 0.25 μ μ f; 500V	82003
C-103	0.3 - 3 μ μ f	Capacitor, variable: Pyrex Tubular	84088
C-104A		Capacitor, variable	Special
C-104B		Capacitor, variable	Special
C-105	0.001 μ f	Capacitor, fixed: $+80\%$ -20% ; 600V	82306
C-106,C-107	0.001 μ f	Capacitor, fixed: $\pm 10\%$; 500V	82310
C-108		Capacitor, variable	Special
C-109,C-110	0.001 μ f	Capacitor, fixed: $\pm 10\%$; 500V	82310
C-111,C-112	2 μ μ f	Capacitor, fixed: ± 0.25 μ μ f; 500V	82002
C-113	1500 μ μ f	Capacitor, fixed: $\pm 20\%$; 500V	82318
C-114	1000 μ μ f	Capacitor, fixed: $\pm 10\%$; 500V	82307
L-100	0.295 μ h	Coil, Radio Frequency	300824
L-101	0.001 μ h	Coil, Radio Frequency	300931
L-102	0.09 μ h	Coil, Radio Frequency	300825
L-103	1.3 μ h	Coil, Radio Frequency	300823
L-104	0.0028 μ h	Coil, Radio Frequency	300827
R-100,R-101	22 k Ω	Resistor, fixed: $\pm 5\%$; $\frac{1}{2}$ W	80472
R-102-R-105	330 Ω	Resistor, fixed: $\pm 5\%$; $\frac{1}{2}$ W	80172
R-106	15 Ω	Resistor, fixed: $\pm 5\%$; $\frac{1}{2}$ W	80011
R-107,R-108	1 k Ω	Resistor, fixed: $\pm 5\%$; $\frac{1}{2}$ W	80148
R-109	15 Ω	Resistor, fixed: $\pm 5\%$; $\frac{1}{2}$ W	80011
R-110	100 Ω	Resistor, fixed: $\pm 5\%$; $\frac{1}{2}$ W	80062
R-111	470 Ω	Resistor, fixed: $\pm 5\%$; $\frac{1}{2}$ W	80170
S-100		Frequency range turret	Special
S-101		Micro Switch	301076
V-100,V-101		Tube: 5718	
V-102		Tube: selected 9005	537B
V-103		Tube: selected 9005	537A

Voltmeter Section

C-200,C-201	0.01 μ f	Capacitor, fixed: $+80\%$ -20% ; 600V	82428
M-200		Meter: Q Voltmeter	307167
R-200	3 k Ω	Resistor, variable: $\pm 10\%$; 4W	81210
R-201	150 k Ω	Resistor, fixed: $\pm 5\%$; $\frac{1}{2}$ W	80564
R-202	3 k Ω	Resistor, variable: $\pm 10\%$; 4W	81210
R-203	4 k Ω	Resistor, fixed: $\pm 5\%$; 5W	80261

BOONTON RADIO COMPANY

ELECTRICAL COMPONENTS

R-F SECTION

Circuit Symbol	Value	Description	BRC Part No.
R-204, R-205	200 Ω , 15 Ω	Resistor, variable: $\pm 10\%$; 3W, dual	81212
R-206	470 k Ω	Resistor, fixed: $\pm 5\%$; 1/2W	80640
R-207	2.2 k Ω	Resistor, fixed: $\pm 5\%$; 1/2W	80256
R-208	3 k Ω	Resistor, variable: $\pm 10\%$; 2W	81211
R-209	2.2 k Ω	Resistor, fixed: $\pm 5\%$; 1/2W	80256
R-210	10 k Ω	Resistor, fixed: $\pm 5\%$; 1/2W	80361
R-211, R-212	6.8 Meg Ω	Resistor, fixed: $\pm 5\%$; 1/2W	80642
R-213, R-214	3 k Ω	Resistor, variable: $\pm 10\%$; 2W	81211
R-215	10 k Ω	Resistor, variable: $\pm 10\%$; 2W	81330
R-216	7.5 k Ω	Resistor, variable: $\pm 10\%$; 2W	81307
R-217	4.4 k Ω	Resistor, fixed: $\pm 1\%$; 1/2W	80352
R-218	6.3 k Ω	Resistor, fixed: $\pm 1\%$; 1/2W	80353
R-219	37 k Ω	Resistor, fixed: $\pm 1\%$; 1/2W	80355
R-220	1.4 k Ω	Resistor, fixed: $\pm 1\%$; 1/2W	80354
R-222	470 Ω	Resistor, fixed: $\pm 5\%$; 2W	80123
R-223	20 k Ω	Resistor, variable: $\pm 10\%$; 4W	81419
S-200A, B, C		Switch, lever: "XQ"	301072
S-201A, B, C		Switch, lever: " Δ Q"	301072
S-202		Switch, lever: "LOQ"	301071
V-200		Tube: selected 12AT7	538A
Power Supply			
C-300	60 μ f	Capacitor, fixed: 300V, insulated	83100
C-301, C-302	60 μ f	Capacitor, fixed: 300V	83048
CR-300, CR-301	100 MA	Rectifier, selenium	300316
F-300, F-301	.75 A	Fuse: type 3AG	95011
I-300	6.3V, 0.15 A	Lamp, incandescent	90904
J-300		Connector, female: 8-contact	89047
L-300	5 H	Choke, filter	85412
P-300		Connector, male: 8-contact	94148
R-300	75 Ω	Resistor, fixed: $\pm 5\%$; 5W	80063
R-301	2k Ω	Resistor, fixed: $\pm 5\%$; 5W	80210
S-300		Switch, toggle	88059
T-300		Transformer, filament	301067
V-300		Tube: OB2	
VR-300		Voltage regulator	85028

MODEL 190-A Q METER

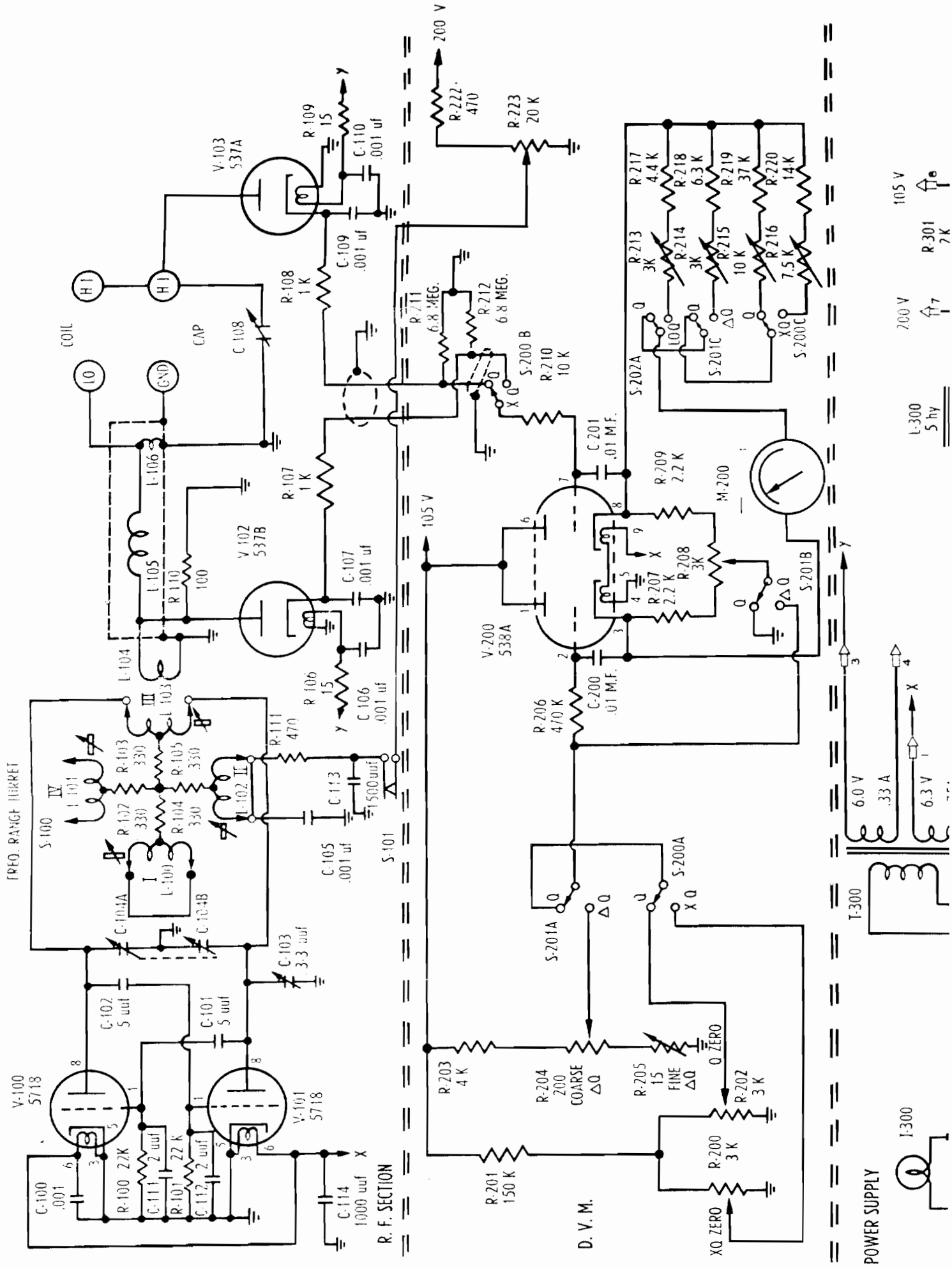

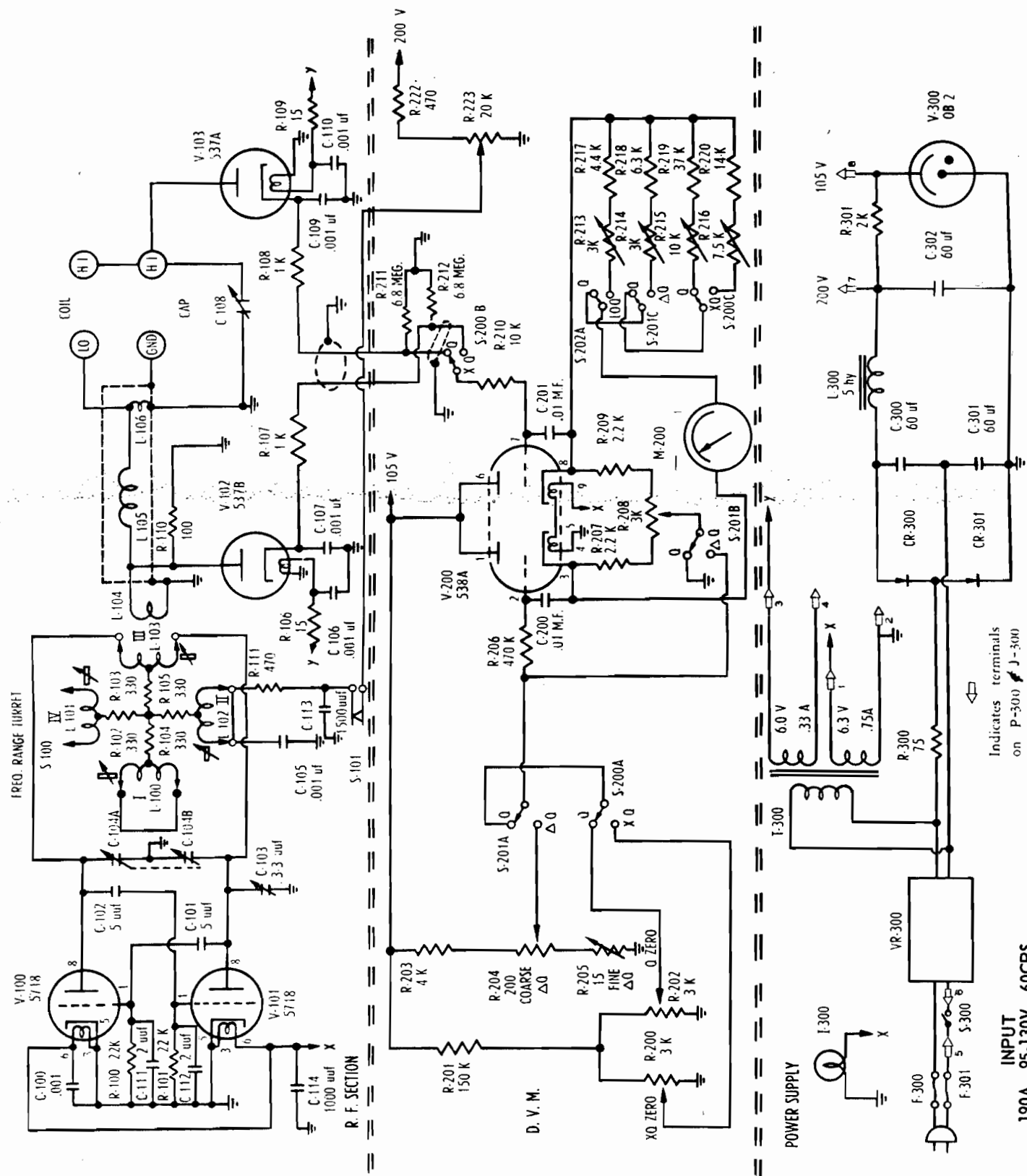

INPUT
190A 95-130V, 60CPS
190AP 95-130V, 50CPS

Indicates terminals
on P-300 J-300

FIG. IX-2 SCHEMATIC DIAGRAM Q METER 190-A

TABLE OF REPLACEABLE PARTS

Ref. Designator	HP Part No.	TQ	Description	Mfr.	Mfr. Part No.
C100	0160-0160	1	C: fxd mica 1000pF 10% 500 vdcw	18796	651-006
C101	0160-0182	2	C: fxd cer 5pF 5% 500 vdcw	00656	CN-1
C102	0160-0182		C: fxd cer 5pF 5% 500 vdcw	00656	CN-1
C103	0121-0072	1	C: var glass 0.5-3pF 600 vdcw	06486	obd
C104	00190-60023	0	Capacitor Assembly (reference only - NRFR)	28480	00190-60023
C105	0150-0050	1	C: fxd cer 1000pF 600 vdcw	28480	0150-0050
C106	0160-0733	1	C: fxd mica 1000pF 10% 500 vdcw	18796	655-000-01A0 102K
C107	0160-0419	1	C: fxd cer 1000pF 500 V stud mtg	01121	555D-102W
C108	00190-60006	1	Capacitor Assembly, Q-capacitor (reference only - NRFR)	28480	00190-60006
C109	0160-0128	2	C: fxd mica 1000pF 10% 500 vdcw	18796	652-005
C110	0160-0128		C: fxd mica 1000pF 10% 500 vdcw	18796	652-005
C111	0160-0481	2	C: fxd cer 2.0pF 20% 500 vdcw	00656	CN-1
C112	0160-0481		C: fxd cer 2.0pF 20% 500 vdcw	00656	CN-1
C113	0160-0734	2	C: fxd cer fdthru 1500pF 500 vdcw	09769	362X5U152M
C114	0160-0734		C: fxd cer fdthru 1500pF 500 vdcw	09769	362X5U152M
C115	0160-3503	1	C: fxd cer 0.5pF 10% 100 vdcw		
C200	0160-0992	2	C: fxd cer 0.01μF 450V	71590	48-003A (type DAC)
C201	0160-0992		C: fxd cer 0.01μF 450V	71590	48-003A (type DAC)
C300	0180-0246	3	C: fxd electrolytic alum	56289	TVL1570
C301	0180-0246		C: fxd electrolytic alum	56289	TVL1570
C302	0180-0246		C: fxd electrolytic alum	56289	TVL1570
CR101	1901-0518	1	Diode: Hot Carrier, replaces V102 after serial number 2535	28480	1901-0518
CR300	1901-0029	2	Diode: Si 600 PIV 0.75A	04713	SR-1358-10
CR301	1901-0029		Diode: Si 600 PIV 0.75A	04713	SR-1358-10
F300	2110-0019	1	Fuse: 0.4A 125V slow blow (230V operation)	71400	MDL 4/10
F300	2110-0020	1	Fuse: 0.8A 125V slow blow (115V operation)	71400	MDL 8/10
I300	2140-0009	1	Lamp: incandescent No. 47 6.3V .15mA	13688	47
J300	1200-0002	1	Socket: tube (used as connector)	91662	04-813-09
J301	1251-0148	1	Connector: ac power 3 pin receptacle	87930	1065-1
L100	00190-60039	1	Coil: range I, 11-1/2 turns 28AWG	28480	00190-60039
L101	00190-60040	1	Coil: range II, 5-1/2 turns 22AWG	28480	00190-60040
L102	00190-60041	1	Coil: range III, 2-1/2 turns 20AWG	28480	00190-60041
L103	00190-80001	1	Coil: range IV, 1/2 turn 1/4" radius 18AWG	28480	00190-80001
L104	00190-80003	2	Coil: pickup, 1 turn 3/8" radius 18AWG	28480	00190-80003
L300	9110-0089	1	Choke: filter 5Hz at 75mA 200 ohm dc	73886	24913
M200	1120-0330	1	Meter: scale	55026	obd
P300	1251-0434	1	Connector: plug ac power 3 pin receptacle	74868	86PM8-11
R100	0686-2235	2	R: fxd comp 22K 5% 1/2w	01121	EB2235
R101	0686-2235		R: fxd comp 22K 5% 1/2w	01121	EB2235
R102	0686-3315	5	R: fxd comp 330 ohm 5% 1/2w	01121	EB3315
R103	0686-3315		R: fxd comp 330 ohm 5% 1/2w	01121	EB3315
R104	0686-3315		R: fxd comp 330 ohm 5% 1/2w	01121	EB3315
R105	0686-3315		R: fxd comp 330 ohm 5% 1/2w	01121	EB3315
R106	0686-1505	0	R: fxd 15 ohm 5% 1/2w	01121	EB1505
R107	0686-1025	2	R: fxd comp 1K 5% 1/2w	01121	EB1025
R108	0686-1025		R: fxd comp 1K 5% 1/2w	01121	EB1025
R109	0686-3315		R: fxd comp 330 ohm 5% 1/2w	01121	EB3315
R110	0686-1015	1	R: fxd comp 100 ohm 5% 1/2w	01121	EB1015
R111	0686-4715	1	R: fxd 470 ohm 5% 1/2w	01121	EB4715
R200	2100-0848	2	R: var ww 3K ±10% 4w	71450	series 25
R201	0758-0061	1	R: fxd met flm 120 Kohm ±5%		
R202	2100-0848		R: var ww 3K ±10% 4w	71450	series 25
R203	0812-0068	1	R: fxd ww 4000 ohm ±5% 7w	56289	obd
R204	2100-0840	2	R: var 200 ohm	12697	type 58
R205	2100-0840		R: var 200 ohm	12697	type 58
R206	0686-4745	4	R: fxd comp 470K ±5% 1/2w	01121	EB4745
R207	0686-2225	2	R: fxd comp 2.2K 5% 1/2w	01121	EB2225
R208	2100-0829	3	R: var 3K ±10% 2w	12697	series 43
R209	0686-2225		R: fxd comp 2.2K 5% 1/2w	01121	EB2225

TABLE OF REPLACEABLE PARTS

Ref. Designator	HP Part No.	EQ	Description	Mfr.	Mfr. Part No.
R210	0686-1035	1	R: fxd comp 10K 5% 1/2w	01121	EB1035
R211	0686-0850	2	R: fxd 6.8M Ω \pm 5% 1/2w	01121	EB6855
R212	0686-0850		R: fxd 6.8M Ω \pm 5% 1/2w	01121	EB6855
R213	2100-0829		R: var 3K \pm 10% 2w	12697	series 43
R214	2100-0829		R: var 3K \pm 10% 2w	12697	series 13
R215	2100-0828	1	R: var 10K \pm 10% 2w	12697	series 43
R216	2100-0819	1	R: var 7.5K \pm 10% 2w	12697	series 43
R217	0811-0350	1	R: fxd 1100 ohm \pm 1% 1/2w	07088	EP-09
R218	0811-0351	1	R: fxd 6300 ohm \pm 1% 1/2w	07088	EP-09
R219	0811-0353	1	R: fxd 37K \pm 1% 1/2w	07088	EP-09
R220	0811-0352	1	R: fxd 11K \pm 1% 1/2w	07088	EP-09
R221					
R222	0692-1715	1	R: fxd 170 ohm \pm 5% 2w	01121	HB-1715
R223	2100-0841	1	R: var 20K \pm 10% 4w	12697	series 10
R224	0758-0016	1	R: fxd met flm 300 ohm \pm 5% 1/4w	14674	C5
R300	0812-0067	1	R: fxd ww 75 ohm \pm 5% 7w	56289	454E7505
R301	0812-0069	1	R: fxd ww 2000 ohm \pm 5% 7w	56289	454E202J
S100	00190-60037	1	Turret Assembly (reference only - includes L100-L103, R102-R105)	28480	00190-60037
S101	3102-0015	1	Switch: 5A 125-250Vac (sensitivity)	82389	
S200A,B,C	3100-0797	6	Switch: lever	72663	obd
S201A,B,C	3100-0797		Switch: lever	72663	obd
S202	3100-0798	1	Switch: lever	72663	type MCT-1
S300	3101-0005	1	Switch: toggle DPDT 6A 125V	04009	81027-CEJ
S301	3101-0034	1	Switch: slide 115/230V power	82389	11E-1006A
T300	9100-0256	1	Transformer: 6.3V 0.75A, 6.0V at 0.33A	73886	22578
V100	1921-0011	2	Tube: electron submin triode 5718	86684	obd
V101	1921-0011		Tube: electron submin triode 5718	86684	obd
*V102	1920-0011	0	Tube: electron (selected 9005)	86684	obd
V103	1920-0009	1	Tube: electron 6923/EA52	73445	6923/EA52
*V103	00190-80004	0	Tube: electron (selected 9005)	28480	00190-80004
V200	1932-0027	1	Tube: electron 12AT7	24972	obd
V300	1940-0007	1	Tube: electron (OB2)	86684	obd
VR300	9100-0265	1	Stabilizer: voltage, for 190A (60 Hz operation)	00159	T-1-31370
VR300	9100-0276	1	Stabilizer: voltage, for 190A-AP(50Hz operation)	00159	T-1-47017
XF300	1400-0084	1	Holder: fuse	75915	312014
XI300	1450-0099	1	Holder: lamp	72619	502-8140-2131-100
XV200	1200-0019	1	Socket: tube	71785	121-39-22-011
XV300	1200-0045	1	Socket: tube	71785	113-43-12-056
MISCELLANEOUS					
	0370-0023	1	Knob, Δ Q BALANCE	28480	0370-0023
	0370-0029	1	Knob, SET XQ	28480	0370-0029
	0370-0038	1	Knob, frequency control	28480	0370-0038
	0370-0094	1	Knob, Q zero	28480	0370-0094
	0370-0095	1	Knob, X zero	28480	0370-0095
	0370-0141	1	Knob, Q capacitor control	28480	0370-0141
	00190-20057	1	Fiducial, MMFD dial	28480	00190-20057
	00190-20058	1	Fiducial, MC dial	28480	00190-20058
	00190-60054	1	Dial Knob Assembly - FREQ	28480	00190-60054
	00190-60055	1	Dial Knob Assembly - MMFD	28480	00190-60055

* Not used after Serial Number 2535