



**Electro-Voice®**  
a gulton company

## Model RE30 Omni Line/Mike Level Condenser Microphone

### SPECIFICATIONS

**Element:**

Electret condenser

**Frequency Response:**

40 to 15,000 Hz (see Figure 1)

**Polar Pattern:**

Omnidirectional (see Figure 2)

**Output Impedance @ 1000 Hz,**

**Line Level Mode:**

Less than 200 ohms

**Mike Level Mode:**

Approximately 2 ohms (usable into nominal lo "Z" inputs)

**Output Level @ 1000 Hz,**

**Line Level Mode:**

Open Circuit Voltage — -19 dBv (0.11 V) for 74 dB SPL (0 dBv = 1 volt)

Power Output — 0 dBm into 600 ohms for 94 dB SPL (0 dBm = 1 mW into 600 ohms)

**Mike Level Mode:**

Open Circuit Voltage — -75 dB (0 dB = 1 volt/dyne) taken below limiter threshold

Equivalent Low "Z" Power Sensitivity into 150 Ohms — -54 dB (0 dB = 1 mW/10 dynes)

**Limiter,**

**Threshold:**

+6 dBm (approximately 100 dB SPL)

**Attack Time:**

Typically 2 msec for 10 dB input change

**Release Time:**

Typically 100 msec for 10 dB input change

**Range:**

30 dB

**Output Clipping Level:**

+10 dBm (see Figure 3)

**Total Harmonic Distortion:**

(Measured at 1000 Hz with a +4 dBm output level) 1% or less

**Hum Sensitivity:**

Less than -128 dBm in a 1 millioersted field @ 60 Hz

**Equivalent Noise Level:**

30 dB SPL "a" weighted

**Battery Power,**

**Type:**

9-volt alkaline  
Mallory MN1604  
Eveready 522  
Burgess 2NG  
NEDA 1604A

**Average Life:**

80 hours (termination of electro-pulse operation)

**Electro-Pulse Termination**

**Voltage:**

6.5 V

**Current Drain (Typical):**

3.5 mA (idle) — approximately 10 mA (full swing)

**Phantom Power,**

**Voltage:**

Any phantom supply capable of 12.5 V (minimum) at 15 mA to the microphone

**Current Drain:**

15 mA

**Operating Conditions,**

**Temperature:**

-29° to 57° C (-20° to 135° F)

**Case Material,**

**Handle Portion:**

Electrically conductive graphite reinforced nylon with steel inserts

**Tubular Barrel:**

Screw machined aluminum and steel

**Transducer Assembly:**

Screw machined steel and case hardened steel grille screens

**Case Dimensions:**

(See Figure 4)

**Finish:**

Satin black

**Net Weight:**

332 g (11.7 oz) with battery

**Microphone Overload and Shorting Protection,**

**Shorting:**

Pin 2 to 3 no damage (may decrease battery life) Pin 2 to Pin 1 or Pin 3 to Pin 1 no damage and no effect on battery life or output level. Maximum external voltage applied between Pins 2 and 3 — 50 V. Maximum external voltage applied to Pin 2 or 3 and Pin 1 — 50 V

**Connections:**

(See Figure 5, Block Diagram of circuit)

**Accessories Furnished:**

Stand clamp  
Zippered vinyl carrying case

**Optional Accessories:**

AC24M power supply  
379 Series colored windscreens

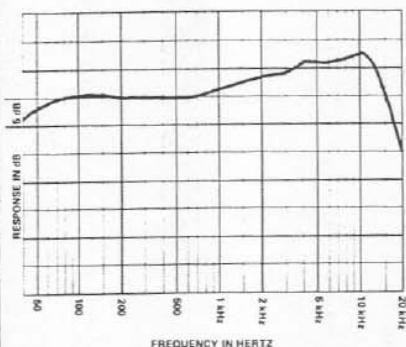

FIGURE 1 — Frequency Response

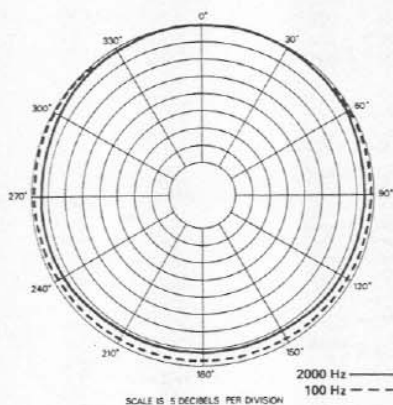

FIGURE 2 — Polar Pattern

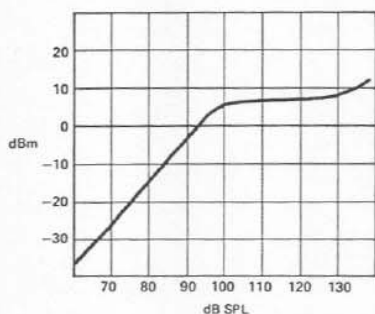

FIGURE 3 — Limiter Threshold

## DESCRIPTION

The RE30 is a handheld condenser omni microphone employing a transformer coupled line level amplifier, peak limiter, standard 9-volt battery, switchable line-to-mike level attenuator, "electro-pulse" battery status indicator, and supply voltage sensing remote "Q" light. It is designed to provide line or mike level outputs of broadcast quality under adverse conditions or in situations where either line level and/or limiting are desired, such as telephone line feeds and connection to microwave transmitters.

The RE30's handle has been designed for "long periods" of handheld use. Its rectangular shape can be gripped with minimal force and can even be firmly grasped by gloved hands. It is made of a super strong graphite reinforced plastic that is stronger than most metals. The RE30 handle, as a result, is far lighter than most microphone handles and in cold conditions it will not chill the user's hand.

Two switches are provided in the forward portion of the handle section. The top switch, which protrudes slightly from the surface, is the battery mute switch. When the RE30 is battery powered, the top switch can be turned off to conserve battery power. Microphone output is shorted in the off position and phantom power, if present, is not terminated so the top switch functions as a "silent" mute switch when the RE30 is phantom powered. It is mounted across the handle to reduce the chance of accidental activation by normal hand movements.

The bottom switch controls the internal line-level-to-microphone-level attenuator. It is deeply recessed to prevent activation by normal finger movements. Since the RE30's limiter still functions in the "mike level" position and the output level is tailored to the typical input stage, the RE30 will not overload the first stage of most microphone preamplifiers while retaining the output required for the best signal-to-noise ratio.

Between the two switches is the "electro-pulse"/phantom "Q" indicator (see Figure 6). When the RE30 is turned on and a new battery is in place the indicator will flash rapidly. As the battery's voltage drops the flashing rate slows giving the user a continuous

indication of battery condition. In non-critical applications the RE30 can be operated until the flashing completely ceases; there is approximately five hours of reduced performance operation after the "electro-pulse" stops flashing. In critical applications and those requiring maximum performance, the battery should be replaced when the flashing rate drops to approximately one flash every second.

The L.E.D. indicator between the switches, in addition to its "electro-pulse" function, can also be employed as a phantom presence indicator and/or as a remote "Q" light ("Q" light refers to a cue or tally light). When the phantom voltage applied to the microphone rises above 12.5 volts, the indicator glows continuously. A properly operating phantom supply system will light the indicator. If the indicator fails to light, the system should be checked to determine the reason for the lack of sufficient power for proper operation. On some properly operating systems the presence of strong sonic inputs will cause the indicator to dim as the microphone draws more current in response to the increased input.

If the phantom supply is modified (see Figure 7), the phantom presence indicator can be used as a remote "Q" light. The modified supply provides the microphone sufficient current to operate normally at a voltage just below the indicator's activation point. The supply has a switch or relay contact that raises the feed voltage above the activation point and the light lights. By controlling the rate of voltage change and through proper feed resistor selection, the light can be switched on and off with no audible side effects.

The phantom "Q" allows the station, truck, studio, etc. to directly signal the "talent" at any time via the microphone line. Note: The "Q" light functions even if the power switch is off. This feature prevents the station signal from being accidentally cut off by use of the mute function.

In most applications the use of a "battery" as a fail safe backup is recommended. When a battery is used in conjunction with a phantom supply the indicator will flash whenever the unit is turned on. If a phantom power supply

is in use, the current drain on the battery is reduced to the fraction of a milliamp required to operate the "electro-pulse circuit". When the "Q" light is on, the flashing of the "electro-pulse" circuit is super-imposed on the continuous glow of the "Q" signal.

In addition to its superior feel, the rectangular handle employed in the RE30 design provides the dimensions necessary to house a "standard" rectangular 9-volt snap terminal battery. The use of a standard alkaline battery is one of the most important features of the RE30 design. When compared to the small cylindrical mercury batteries often employed in microphone products, the standard 9-volt alkaline battery provides many advantages:

1. It is the most readily available multi-cell battery. It can be purchased at grocery stores, all night drug stores, etc. A "typical" multicell mercury battery, if available at all, can only be found in a specialty store such as a camera store.
2. Low cost and high capacity. A 9-volt alkaline battery, Mallory MN1604, like the one used by the RE30 can be purchased for approximately a third of the cost of a 9.8-volt mercury battery (Eveready E177), and it can provide nearly twice the usable energy.
3. An alkaline battery will operate at very low temperature,  $-20^{\circ}\text{F}$ . A mercury cell begins losing output at  $40^{\circ}\text{F}$ .
4. The voltage of an alkaline cell drops slowly but predictably as its capacity is consumed. A mercury battery retains the same voltage until virtually all of its capacity is consumed. As a result, it is impossible to determine the capacity remaining in a mercury battery and microphone failures due to battery discharge occur rapidly with no prior warning.
5. 9-volt alkaline batteries can be reliably terminated. The snap terminals provide multiple high pressure contacts that move with the battery when the microphone is bumped. Since alkaline batteries don't vent corrosive gasses like mercury batteries, there is less likelihood of contact corrosion. To take maximum advantage of the standard 9-volt battery's snap terminals, the RE30 employs a premium battery clip with high contact pressure snaps.

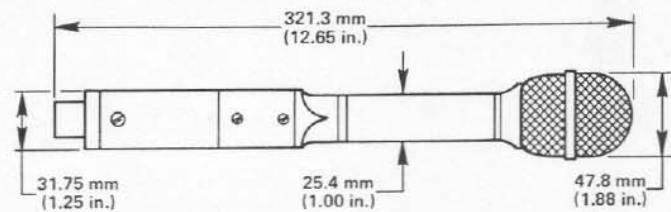

FIGURE 4 – Case Dimensions

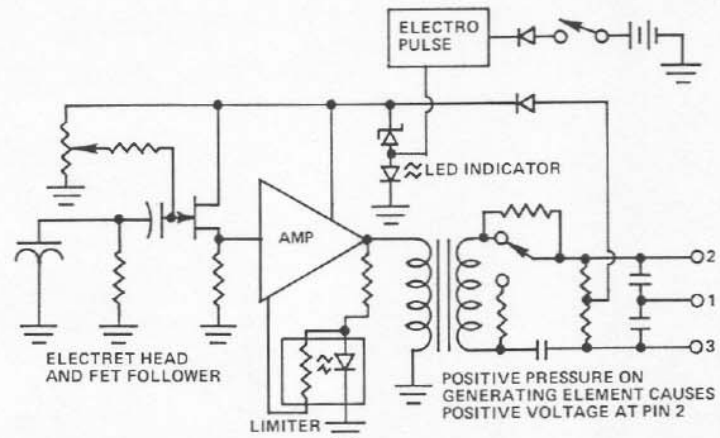

FIGURE 5 – Circuit Block Diagram

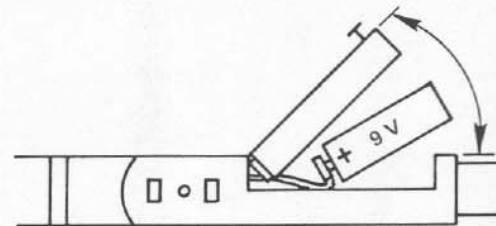

FIGURE 6 – Switch/battery Compartment Diagram

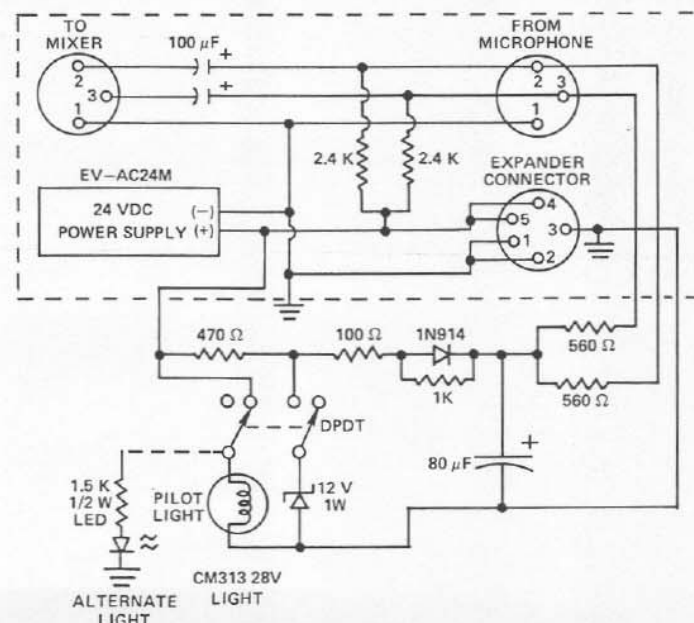

FIGURE 7 – Remote "Q" Light Activation Circuit

The line level amplifier is housed in the cylindrical portion of the RE30. It employs discrete components to achieve the optimum combination of output capability and minimal current demand. A key feature of the RE30 line level amplifier is the use of a relatively large, saturation-resistant transformer in its output stage. The use of a transformer affords several significant advantages over "transformerless" balanced output systems:

1. When operated into an "unbalanced" load the output level and current demand of the RE30 are unchanged. A "typical" transformerless unit drops 6 dB in output and its current demand increases dramatically because one-half of its output is shorted to ground.
2. The "truly" balanced output of the RE30 is immune to ground loops, the major reason for the existence of balanced lines. Since a "typical" transformerless unit consists of two "unbalanced" outputs of opposite polarity, the unconditional immunity to ground loops is forfeited.
3. Through the proper adjustment in the turns ratio, the transformer can be used to optimize the coupling between the amplifier and the load. The RE30's transformer increases the output swing of the RE30 which, in turn, increases battery life by allowing "full swing" from a lower battery voltage.
4. The transformer acts as a protective barrier between the amplifier and voltage spikes entering from the output cable. The RE30 transformer employs a 200-volt insulator between its primary and secondary windings to improve its protective aspects.

The transducer preamplifier, transducer, and windscreens are housed in the transducer assembly. By separating the extremely high impedance transducer preamplifier from the line level amplifier, the RE30's sensitivity to handling noise and humidity have been greatly reduced.

Moisture can, in many condenser amplifiers, condense on the P.C. boards, etc. and reduce the resistance between the F. E. T.'s gate and surrounding leads to the point where operation either ceases or is significantly impaired. This is not true in the RE30. The RE30's moisture sensitive contacts are totally encased in non-hydroscopic potting compound. In addition, the RE30 employs a low leakage capacitor

between the gate and transducer leads. This capacitor provides several significant advantages:

1. By blocking the F.E.T bias voltage from the transducer's electrode system it prevents the mechanical shock induced output that normally occurs when the electrode system moves relative to the grounded case.
2. By blocking the bias voltage it prevents the conduction to ground of the bias voltage across internal transducer insulators. This makes the RE30 exceptionally immune to humidity and moisture.
3. The RE30 employs an "across the transducer" resistance to roll off the bass response "before" the F.E.T. stage. This roll off protects the F.E.T. stage and all following stages from overloads resulting from p-pops and proximity effect bass end overloads. The RE30's bass response is deliberately "shaped" to afford the the best sonic character in its intended use as a handheld microphone.

#### APPLICATIONS:

The RE30's reliability, ruggedness, line level output, remote "Q" light, etc. make it the ideal choice in many broadcast applications. The following is a partial list of applications in which the RE30 excels:

1. Single-channel remotes. No additional amplification required. Remote signaling from the studio is possible using the phantom "Q" light, so long as the line transfers phantom power.
2. Connection to line level inputs on microwave and fiber optic transmitters.
3. Long-run microphone lines, unshielded lines, unbalanced lines in electronically noisy environments. E.N.G., E.F.P., and live events such as golf tournaments, etc.
4. "Dialed-Up" telephone lines and leased telephone lines. The RE30's output system is designed to drive and hold telephone lines. It incorporates dc blocking capacitors and high dissipation line holding resistors to assure proper operation on almost any telephone line.

It will "hold the line" even when its power switch is turned off to conserve its battery.

The line level output of the RE30 produces the maximum allowable input into the phone line. This

assures the best possible signal-to-noise ratio with no overloading of telephone equipment.

**CAUTION: ELECTRICAL CONNECTION TO PUBLIC TELEPHONE LINES IN THE UNITED STATES REQUIRES THE USE OF AN ACCESS MODULE REGISTERED UNDER F.C.C. REGULATION PART 68.**

5. The RE30 can drive P.A. power amplifiers directly and from long unshielded unbalanced lines.
6. Sports announcing. The built-in limiter works in both mike and line level operation so the RE30's limiter will provide overload protection along the entire signal path once the proper gain settings are made.

#### WARRANTY (Limited)

Electro-Voice Professional Broadcast, Recording, and Sound Reinforcement Microphones are guaranteed unconditionally against malfunction from any cause for a period of two years from date of original purchase. Also, these microphones are guaranteed without time limit against malfunction in the acoustic system due to defects in workmanship and materials. (Any active electronics incorporated in a microphone is guaranteed for three years from date of original purchase against such malfunction.) If such malfunction occurs, microphone will be repaired or replaced (at our option) without charge for materials or labor if delivered prepaid to the proper Electro-Voice service facility. Unit will be returned prepaid. Warranty does not cover finish, appearance items, cables, cable connectors, or switches. Defect guarantee does not cover malfunction due to abuse or operation at other than specified conditions. Repair by other than Electro-Voice or its authorized service agencies will void this guarantee.

For repair information and service locations, please write: Service Department, Electro-Voice, Inc., 600 Cecil Street, Buchanan, Michigan 49107 (Phone: 616/695-6831) or Electro-Voice West, 8234 Doe Ave., P.O. Box 3297, Visalia, CA 93277 (Phone: 209/651-7777).

Electro-Voice maintains complete facilities for non-warranty service of EV products.

Specifications subject to change without notice.