

ENGINEERING DATA MODEL 674 CARDIOID MICROPHONE

DESCRIPTION AND APPLICATIONS

The Electro-Voice Model 674 is a dynamic cardioid microphone, designed specifically for the more exacting public address, communications, and semi-professional and home recording applications.

The exceptionally uniform cardioid pattern of the Model 674 is achieved by careful application of the CV-D™ (Continuously Variable-D) principle – an exclusive Electro-Voice development. With CV-D, the “apparent” length of the slotted tube coupled to the back of the diaphragm varies *inversely* with the frequency of the sound, thus achieving maximum cancellation of sound arriving 180° off axis.

A 3-position bass tilt-down switch provides for adjustment of the low-frequency response of the Model 674 so that the microphone performance can be adapted to the specific environment. Rooms with relatively large volume usually tend to produce some accentuation of the lower frequencies. Attenuation of the low-frequency response of the microphone, which is afforded by the tilt-down switch, results in a more nearly “flat” sound from the total system, and a reduction of the tendency toward feedback. The 3-position bass tilt-down utilizes a slide switch recessed in the rear top of the case just behind the black slotted “CV-D” port. Switch position may be changed by inserting the point of a pencil and pushing gently toward desired position. As shown in Figure 1, response in “0” position is essentially flat, while positions “5” and “10” provide 5 dB or 10 dB attenuation at 100 Hz with uniform rise to approximately 800 Hz.

The attractively styled case and stand mounting stud are durable die-cast zinc. The microphone utilizes the mechanical nesting principle of design in which the

internal parts of the transducer are closely fitted one within another resulting in a structure that is immune to damage from mechanical shock. The exclusive non-metallic Electro-Voice Acoustalloy™ diaphragm is impervious to damage from extremes of humidity, temperature and corrosive effects of salt air. This combination of sturdy case, Acoustalloy diaphragm, and the use of the mechanical nesting principle, results in one of the most durable high performance microphones ever developed.

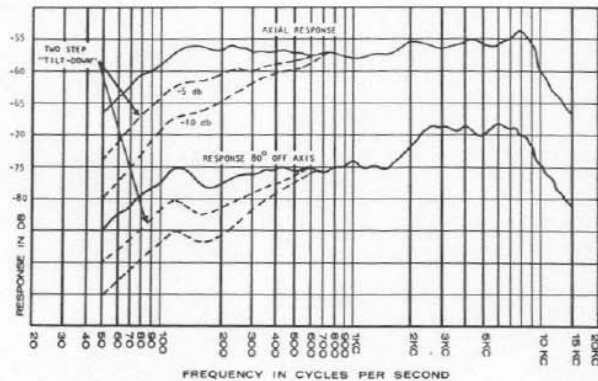

Figure 1 – Frequency Response

SPECIFICATIONS

- Generating Element: Dynamic
- Frequency Response: Uniform, 60–15,000 Hz (Figure 1)
- Polar Pattern: Cardioid (Figure 2)
- Impedance: 150 ohms and high-impedance, selectable at cable connector, 150-ohm impedance balanced to ground

The output level for 150-ohm impedance shall be -57 dB with 0 dB equalling 1 mw/10 dynes/cm². Output level for high impedance shall be -57 dB with 0 dB equalling 1 V/dyne/cm². EIA sensitivity rating shall be -151 dB for 150 ohm impedance and -152 dB for high-impedance.

The microphone case and stand mounting stud shall be pressure-cast zinc. Length of the microphone case measured to center line of swivel mounting shall not exceed 7-7/8". Microphone case diameter shall not exceed 1 1/4". A DPDT switch integral with the stand mounting stud for "on-off" operation shall be provided, and connected so that microphone transducer element will be short-circuited in the off position. Four-position cable connector insert shall be provided in the base of the stand mounting stud that will mate with Electro-Voice Model QC-4M Quick-Change Connector. Net weight shall be 14 ounces (less cable). Finish shall be satin chrome (for Model 674G, finish shall be decorative gold, 674A finish shall be TV gray). A 15-foot, 2-conductor, shielded broadcast type cable shall be provided. An Electro-Voice Model QC-4M Quick-Change Connector shall be provided at the microphone end of the cable. The Electro-Voice Model 674 is specified.

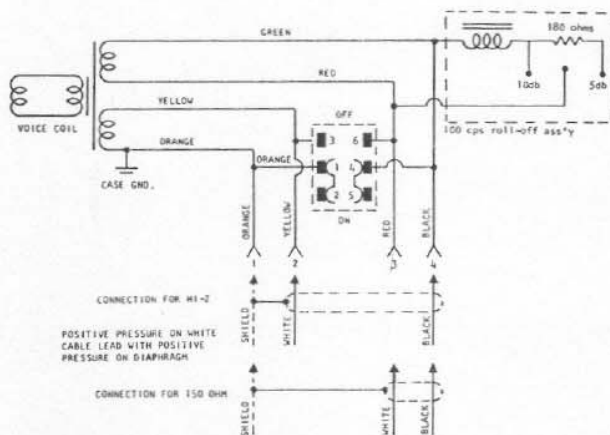

Figure 4 - Wiring Diagram

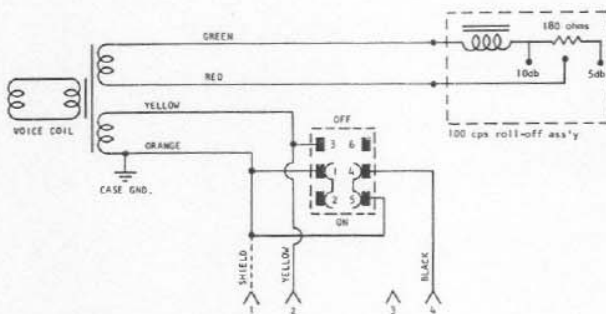

Figure 5 - Wiring Diagram, Modified

INSTRUCTIONS FOR MODIFYING MODEL 674 FOR USE WITH RELAY CONTROL

1. Remove nameplate and switch from stud.
2. Disconnect and tape the black transformer lead from switch Lug No. 4 (center). Black lead Pin No. 4 of cable connector remains connected to switch Lug No. 4.
3. Connect jumper from switch Lug No. 1 to switch Lug No. 5.
4. Disconnect and tape red leads from switch Lug No. 6.
5. If microphone is to be used for occasional VOX operation in addition to relay operation, remove yellow leads from switch Lug No. 3, solder together and insulate with tape.
6. Wiring for relay operation is now complete. Replace switch and nameplate.

The cable may now be connected to obtain relay control between Pins 1 and 4 of the microphone connector. The white cable lead is microphone output, and the black cable lead serves as relay control. The cable shield is ground return for both circuits. Use of AC for relay control is not recommended. Hum and noise may be picked up by the high-impedance lead.

IMPEDANCE CHANGE PROCEDURE FOR E-V QUICK-CHANGE CONNECTOR

For added convenience and flexibility, an Electro-Voice innovation, the QC-4M Quick-Change Connector, is supplied with your Model 674. Change from high-impedance (Hi-Z) to low-impedance (Lo-Z), or the reverse, can now be made quickly and easily without tools.

Figure A shows the basic internal wiring diagram of E-V dual-impedance microphones.

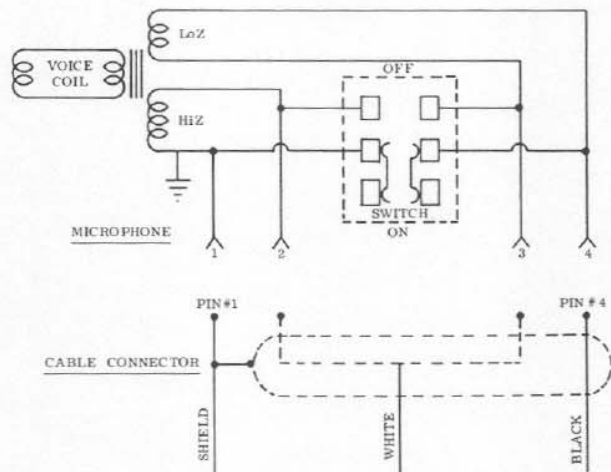

Figure A - Wiring Diagram

Output Level: 150-ohm impedance; -57 dB
(1 mw/10 dynes/cm²)
High impedance; -57 dB
(1 V/dyne/cm²)

EIA Sensitivity Rating,
150-ohm: -151 dB
High impedance: -152 dB

Diaphragm: Acoustalloy

Case Material: Pressure-cast zinc alloy

Case Finish: Satin Chrome. Also available as
Model 674G in decorative gold finish.

On-Off Switch: DPDT switch mounted in stand
mounting stud. (Shorting head in off position)

Dimensions: Microphone only; 7-7/8" x 1 1/4"
diameter. Overall; 10 1/4" x 1 1/4" diameter

Net Weight: 14 ounces, less cable

Cable: 15' 2-conductor, shielded, synthetic
rubber-jacketed broadcast type with QC-4M™
Quick-Change Connector at mike end

Connector in Mike: Amphenol MC-4F

Stud: 5/8"-27 thread provided
for stand mounting

Optional Accessories: Model 418 or 418S
desk stand, Model 376 windscreen

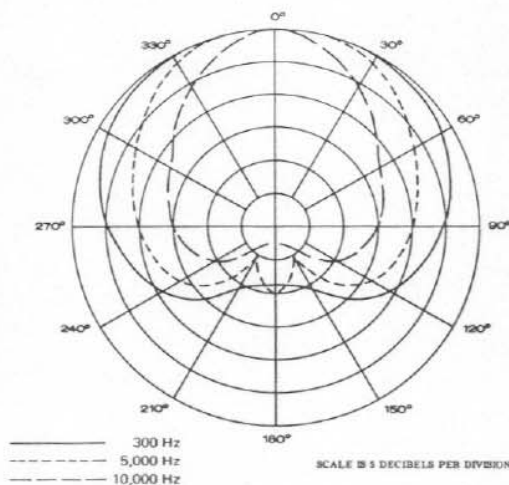

Figure 2 - Polar Pattern

WARRANTY

Each Electro-Voice microphone is guaranteed for the life of the microphone to be free of factory defects in materials and workmanship and will, at our option, be repaired or replaced at no charge if exhibiting malfunction from this cause. Microphones for warranty repair must be shipped prepaid to Electro-Voice, Inc., or its authorized service agency. They will be returned prepaid. This warranty does not cover finish or appearance.

For correct shipping address and instructions on return of Electro-Voice products for repair and locations of authorized service agencies, please write: Service Department, Electro-Voice, Inc., 600 Cecil Street, Buchanan, Michigan 49107 (Phone: 616/695-6831).

Electro-Voice also maintains complete facilities for non-warranty service.

WIRING

It should be noted that the 100 Hz rolloff assembly shown in schematic diagram Figure No. 4, is connected across the low-impedance winding of the microphone transformer, and is a terminating load that is reflected through the transformer whether the microphone is connected for high or low-impedance operation.

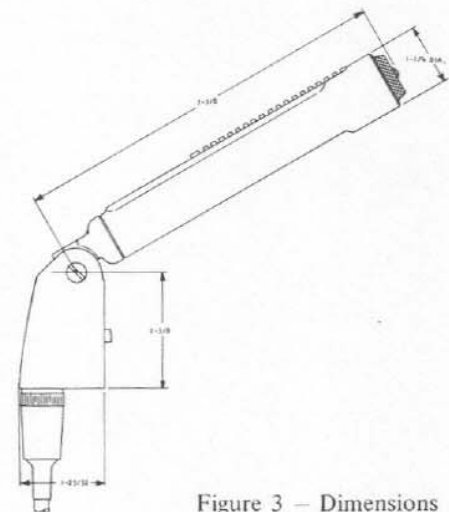

Figure 3 - Dimensions

ARCHITECTS' AND ENGINEERS' SPECIFICATIONS

The microphone shall be a cardioid dynamic type with uniform frequency response from 60 to 15,000 Hz. The diaphragm shall be nonmetallic Acoustalloy and shall have a magnetic shield to prevent dust and iron particles from reaching the diaphragm. It shall be possible to select 150 ohm and high impedance by moving one wire in the cable connector.

The microphone shall be provided with a slotted tube at the back of the diaphragm, the acoustic impedance of which shall cause the tube to act effectively as a point source entrance which varies in distance from the diaphragm inversely with frequency. The resulting phase and amplitude conditions shall provide a smooth unidirectional polar characteristic. An integral bass-tilt switch shall be included, offering choice of 0, 5, or 10 dB attenuation at 100 Hz. Use of bass-tilt switch shall not alter polar pattern.

Note that moving white cable conductor from Pin No. 2 to Pin No. 3 converts the microphone from Hi-Z to Lo-Z.

To change impedance, proceed as follows:

1. Remove cable from microphone by turning the connector shell to left (counter-clockwise) until free, and then gently pull it away from the microphone.

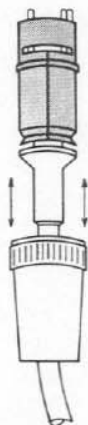

Figure B

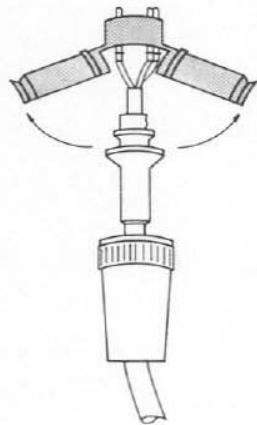

Figure C



Figure D

2. Gripping connector shell firmly in one hand, and cable (near connector) in other hand, firmly push cable into shell so that molded plastic insert slips from shell. (See Figure B)
3. Separate molded insert as shown in Figure C.
4. Note that cable shield and conductors are connected to "slip in" pins. Shield pin is in hole No. 1 of alignment frame, and pin on black conductor is in hole No. 4. These should *not* be changed.
5. The pin connected to the white conductor of your cable should be inserted in hole No. 2, if high impedance operation is desired, or hole No. 3 if low impedance is desired. (See Figure D)
6. Snap molded insert halves into position. (See Figures B and C)
7. Firmly push connector shell back into position (reverse of Step 2). Pressure will be required, since these parts are designed to provide close fit.
8. Align connector guide pin with key slot in the microphone and slip connector into position.
9. Tighten connector shell by turning in clockwise direction.

Your E-V dual impedance microphone is now ready for operation in the impedance you have selected.



a Gulton COMPANY

ELECTRO-VOICE, Inc., 600 CECIL ST., BUCHANAN, MICH. 49107

MANUFACTURING PLANTS AT ■ BUCHANAN, MICH. ■ NEWPORT, TENN. ■ SEVIERVILLE, TENN. ■ GANANOQUE, ONT. ■ SEOUL, KOREA

Part No. 533181—Litho in U.S.A.—240