



Model 5060
GAUSS / TESLA METER

Instruction Manual

Manual UN-01-229
Rev. E, ECO 13097
Item No. 359924
Sypris Test & Measurement
All rights reserved.





*This symbol appears on the instrument and probe.
It refers the operator to additional information
contained in this instruction manual, also identified
by the same symbol.*

NOTICE:

**See Pages 3-1 and 3-2
for SAFETY
instructions prior to first use !**

Table of Contents

SECTION-1 INTRODUCTION	
Understanding Flux Density.....	1-1
Measurement of Flux Density.....	1-2
Product Description.....	1-5
Applications.....	1-6
SECTION-2 SPECIFICATIONS	
Instrument.....	2-1
Standard Transverse Probe.....	2-3
Standard Axial Probe.....	2-4
Optional Probe Extension Cable.....	2-5
Zero Flux Chamber.....	2-6
SECTION-3 OPERATING INSTRUCTIONS	
Operator Safety.....	3-1
Operating Features.....	3-3
Instrument Preparation.....	3-5
Power-Up.....	3-7
Power-Up Settings.....	3-8
Low Battery Condition.....	3-9
Overrange Condition.....	3-10
UNITS of Measure Selection.....	3-11
RANGE Selection.....	3-12
ZERO Function.....	3-13
Automatic ZERO Function.....	3-14
Manual ZERO Function.....	3-16
Sources of Measurement Errors.....	3-18
WARRANTY	4-1

List of Illustrations

Figure 1-1	Flux Lines of a Permanent Magnet.....	1-1
Figure 1-2	Hall Generator.....	1-2
Figure 1-3	Hall Probe Configurations.....	1-4
Figure 2-1	Standard Transverse Probe.....	2-3
Figure 2-2	Standard Axial Probe.....	2-4
Figure 2-3	Optional Probe Extension Cable.....	2-5
Figure 2-4	Zero Flux Chamber.....	2-6
Figure 3-1	Auxiliary Power Connector Warnings.....	3-1
Figure 3-2	Probe Electrical Warning.....	3-2
Figure 3-3	Operating Features.....	3-3
Figure 3-4	Battery Installation.....	3-5
Figure 3-5	Probe Connection.....	3-6
Figure 3-6	Power-Up Display.....	3-7
Figure 3-7	Missing Probe Indication.....	3-8
Figure 3-8	Low Battery Indication.....	3-9
Figure 3-9	Overrange Indication	3-10
Figure 3-10	UNITS Function.....	3-11
Figure 3-11	RANGE Function.....	3-12
Figure 3-12	Automatic ZERO Function.....	3-15
Figure 3-13	Manual ZERO Function.....	3-17
Figure 3-14	Probe Output versus Flux Angle.....	3-19
Figure 3-15	Probe Output versus Distance.....	3-19
Figure 3-16	Flux Density Variations in a Magnet.....	3-20

Section 1

Introduction

UNDERSTANDING FLUX DENSITY

Magnetic fields surrounding permanent magnets or electrical conductors can be visualized as a collection of magnetic *flux* lines; lines of force existing in the material that is being subjected to a magnetizing influence. Unlike light, which travels away from its source indefinitely, magnetic flux lines must eventually return to the source. Thus all magnetic sources are said to have two *poles*. Flux lines are said to emanate from the “north” pole and return to the “south” pole, as depicted in Figure 1-1.

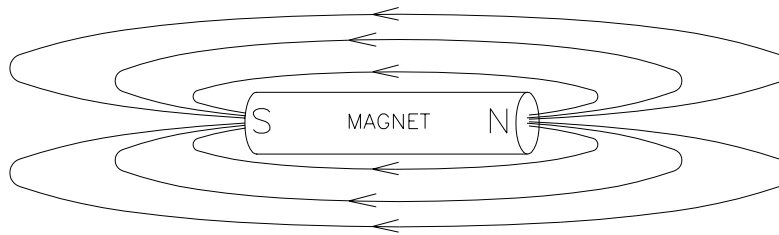

Figure 1-1
Flux Lines of a Permanent Magnet

One line of flux in the CGS measurement system is called a *maxwell* (M), but the *weber* (W), which is 10^8 lines, is more commonly used.

Flux density, also called magnetic induction, is the number of flux lines passing through a given area. It is commonly assigned the symbol “*B*” in scientific documents. In the CGS system a *gauss* (G) is one line of flux passing through a 1 cm^2 area. The more

INTRODUCTION

commonly used term is the *tesla* (T), which is 10,000 lines per cm². Thus

$$1 \text{ tesla} = 10,000 \text{ gauss}$$

$$1 \text{ gauss} = 0.0001 \text{ tesla}$$

Magnetic field strength is a measure of force produced by an electric current or a permanent magnet. It is the ability to induce a magnetic field " B ". It is commonly assigned the symbol " H " in scientific documents. It is important to know that magnetic field strength and magnetic flux density are not the same. Magnetic field strength deals with the physical characteristics of magnetic materials whereas flux density does not.

MEASUREMENT OF FLUX DENSITY

A device commonly used to measure flux density is the *Hall generator*. A Hall generator is a thin slice of a semiconductor material to which four leads are attached at the midpoint of each edge, as shown in Figure 1-2.

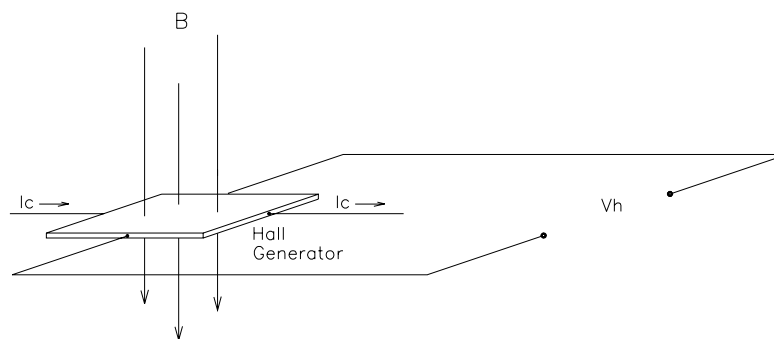

Figure 1-2
Hall Generator

INTRODUCTION

A constant current (I_c) is forced through the material. In a zero magnetic field there is no voltage difference between the other two edges. When flux lines pass through the material the path of the current bends closer to one edge, creating a voltage difference known as the Hall voltage (V_h). In an ideal Hall generator there is a linear relationship between the number of flux lines passing through the material (flux density) and the Hall voltage.

The Hall voltage is also a function of the *direction* in which the flux lines pass through the material, producing a positive voltage in one direction and a negative voltage in the other. If the same number of flux lines pass through the material in either direction, the net result is zero volts.

The Hall voltage is also a function of the *angle* at which the flux lines pass through the material. The greatest Hall voltage occurs when the flux lines pass perpendicularly through the material. Otherwise the output is related to the cosine of the difference between 90° and the actual angle.

The sensitive area of the Hall generator is generally defined as the largest circular area within the actual slice of the material. This *active area* can range in size from 0.2 mm (0.008") to 19 mm (0.75") in diameter. Often the Hall generator assembly is too fragile to use by itself so it is often mounted in a protective tube and terminated with a flexible cable and a connector. This assembly, known as a *Hall probe*, is generally provided in two configurations:

INTRODUCTION

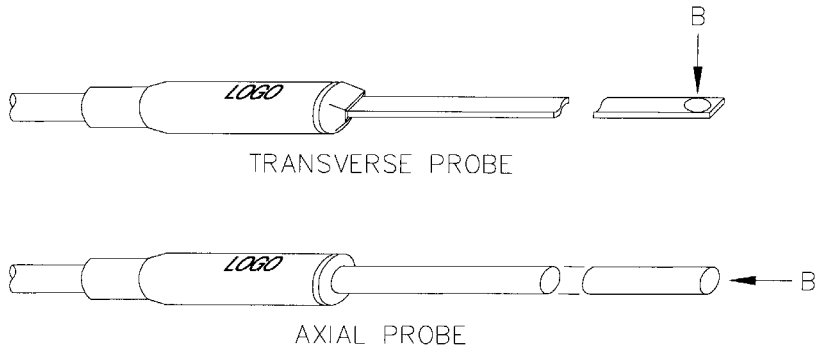

Figure 1-3
Hall Probe Configurations

In “transverse” probes the Hall generator is mounted in a thin, flat stem whereas in “axial” probes the Hall generator is mounted in a cylindrical stem. The axis of sensitivity is the primary difference, as shown by “*B*” in Figure 1-3. Generally transverse probes are used to make measurements between two magnetic poles such as those in audio speakers, electric motors and imaging machines. Axial probes are often used to measure the magnetic field along the axis of a coil, solenoid or traveling wave tube. Either probe can be used where there are few physical space limitations, such as in geomagnetic or electromagnetic interference surveys.



Handle the Hall probe with care. Do not bend the stem or apply pressure to the probe tip as damage may result. Use the protective cover when the probe is not in use.

PRODUCT DESCRIPTION

The *MODEL 5060 GAUSS / TESLAMETER* is a portable instrument that utilizes a Hall probe to measure static (dc) magnetic flux density in terms of gauss or tesla. The measurement range is from 0.1 mT (1 G) to 1.999T (19.99 kG).

The *MODEL 5060* consists of a palm-sized meter and various detachable Hall probes. The meter operates on standard 9 volt alkaline batteries or can be operated with an external ac-to-dc power supply. A retractable bail allows the meter to stand upright on a flat surface. A notch in the bail allows the meter to be wall mounted when bench space is at a premium. The large display is visible at considerable distances. The instrument is easily configured using a single rotary selector and two pushbuttons.

Two measurement ranges can be selected. A “zero” function allows the user to remove undesirable readings from nearby magnetic fields (including earth’s) or false readings caused by initial electrical offsets in the probe and meter. Included is a “zero flux chamber” which allows the probe to be shielded from external magnetic fields during this operation. The “zero” adjustment can be made manually or automatically.

The meter, probes and accessories are protected when not in use by a sturdy carrying case.

INTRODUCTION

APPLICATIONS

- Sorting or performing incoming inspection on permanent magnets, particularly multi-pole magnets.
- Testing audio speaker magnet assemblies, electric motor armatures and stators, transformer lamination stacks, cut toroidal cores, coils and solenoids.
- Determining the location of stray fields around medical diagnostic equipment.
- Determining sources of electromagnetic interference.
- Locating flaws in welded joints.
- Inspection of ferrous materials.
- 3-dimensional field mapping.
- Inspection of magnetic recording heads.

Section 2 Specifications

INSTRUMENT

RANGE		RESOLUTION	
GAUSS	TESLA	GAUSS	TESLA
2 kG	200 mT	1 G	0.1 mT
20 kG	2 T	10 G	1 mT
ACCURACY (including probe): counts		$\pm 4\%$ of reading, ± 3	
ACCURACY CHANGE WITH TEMPERATURE (not including probe):		$\pm 0.02\%$ / °C typical	
WARMUP TIME TO RATED ACCURACY:		15 minutes	
OPERATING TEMPERATURE:		0 to +50°C (+32 to +122°F)	
STORAGE TEMPERATURE:		-25 to +70°C (-13 to +158°F)	
BATTERY TYPE:		9 Vdc alkaline (NEDA 1640A)	
BATTERY LIFE:		8 hours typical (two batteries)	
AUXILIARY POWER:		9 Vdc, 300 mA	
AUXILIARY POWER CONNECTOR:		Standard 2.5 mm I.D. / 5.5 mm O.D. connector. Center post is positive (+) polarity.	

SPECIFICATIONS

METER DIMENSIONS:

Length:	13.2 cm (5.2 in)
Width:	13.5 cm (5.3 in)
Height:	3.8 cm (1.5 in)

WEIGHT:

Meter w/batteries:	400 g (14 oz.)
Shipping:	1.59 kg (3 lb., 8 oz.)

REGULATORY INFORMATION:

Compliance was demonstrated to the following specifications as listed in the official Journal of the European Communities:

EN 50082-1:1992

IEC 801-2:1991
Second Edition
IEC 1000-4-2:1995

Generic Immunity

Electrostatic Discharge
Immunity

ENV 50140:1993
IEC 1000-4-3:1995

Radiated Electromagnetic
Field Immunity

EN 50081-1:1992

EN 55011:1991

Generic Emissions

Radiated and Conducted
Emissions

SPECIFICATIONS

STANDARD TRANSVERSE PROBE

MODEL NUMBER:	HTV56-0602
FLUX DENSITY RANGE:	0 to ± 2 T (0 to ± 20 kG)
FREQUENCY BANDWIDTH:	dc only
OFFSET CHANGE WITH TEMPERATURE:	$\pm 30 \mu\text{T}$ (300 mG) / $^{\circ}\text{C}$ typical
ACCURACY CHANGE WITH TEMPERATURE:	- 0.05% / $^{\circ}\text{C}$ typical
OPERATING TEMPERATURE RANGE:	0 to $+75$ $^{\circ}\text{C}$ ($+32$ to $+167$ $^{\circ}\text{F}$)
STORAGE TEMPERATURE RANGE:	-25 to $+75$ $^{\circ}\text{C}$ (-13 to $+167$ $^{\circ}\text{F}$)

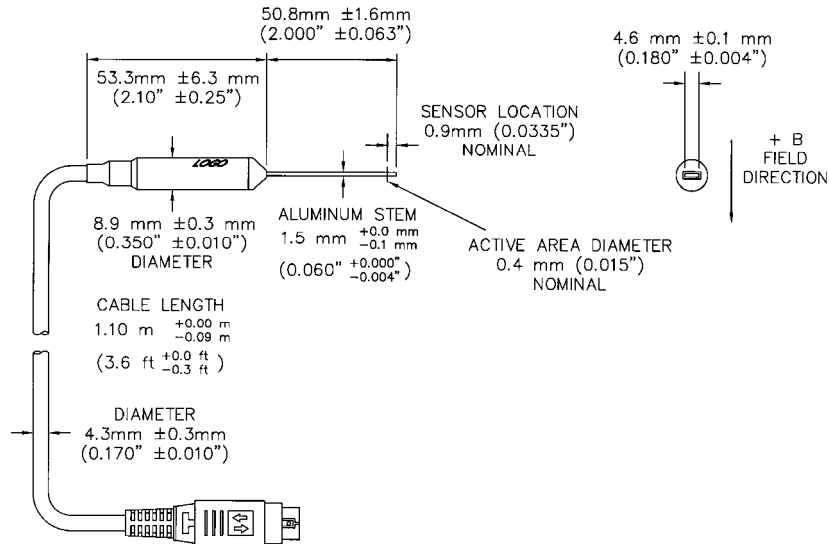

Figure 2-1
Standard Transverse Probe

SPECIFICATIONS

STANDARD AXIAL PROBE

MODEL NUMBER:	SAV56-1904
FLUX DENSITY RANGE:	0 to ± 2 T (0 to ± 20 kG)
OFFSET CHANGE WITH TEMPERATURE:	$\pm 30 \mu\text{T}$ (300 mG) / $^{\circ}\text{C}$ typical
ACCURACY CHANGE WITH TEMPERATURE:	- 0.05% / $^{\circ}\text{C}$ typical
FREQUENCY BANDWIDTH:	dc only
OPERATING TEMPERATURE RANGE:	0 to $+75$ $^{\circ}\text{C}$ ($+32$ to $+167$ $^{\circ}\text{F}$)
STORAGE TEMPERATURE RANGE:	-25 to $+75$ $^{\circ}\text{C}$ (-13 to $+167$ $^{\circ}\text{F}$)

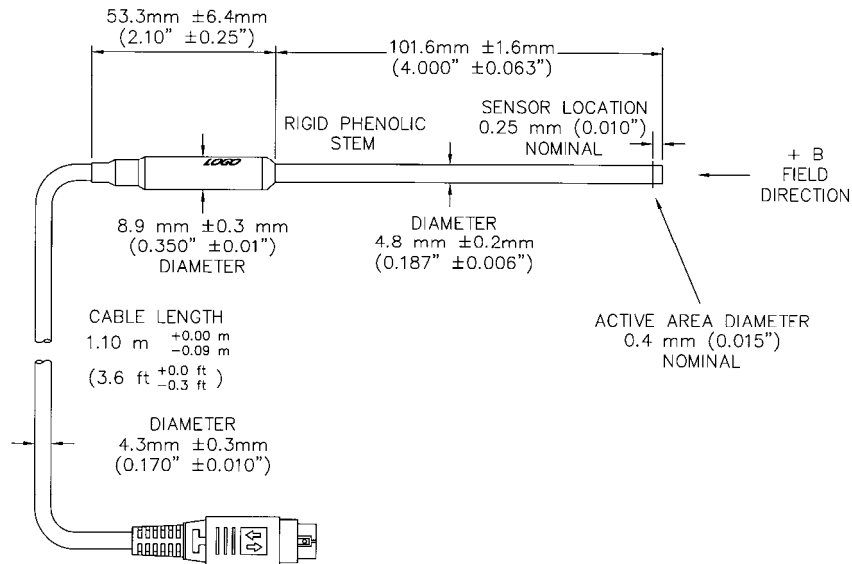

Figure 2-2
Standard Axial Probe

SPECIFICATIONS

OPTIONAL PROBE EXTENSION CABLE

MODEL NUMBER: X5000-0006

OPERATING TEMPERATURE RANGE: 0 to +75 °C (+32 to +167°F)

STORAGE TEMPERATURE RANGE: -25 to +75 °C (-13 to +167°F)

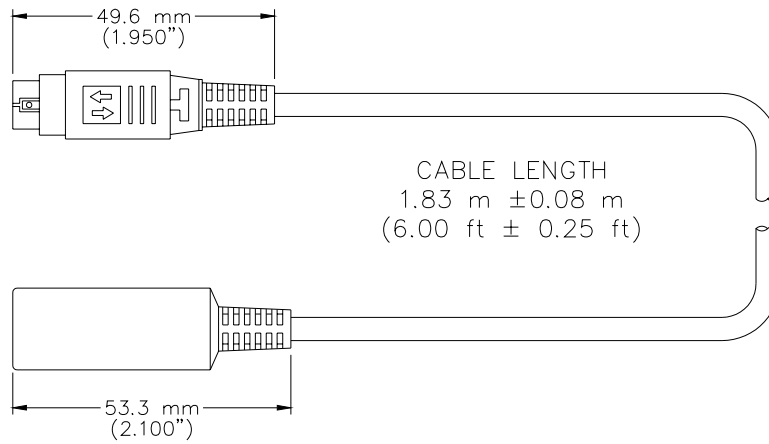

Figure 2-3
Optional Probe Extension Cable

SPECIFICATIONS

ZERO FLUX CHAMBER

MODEL NUMBER: YA-111

CAVITY DIMENSIONS:

Length: 50.8 mm (2")
Diameter: 8.7 mm (0.343")

ATTENUATION: 80 dB to 30 mT (300 G)

PURPOSE: To shield the probe from external magnetic fields during the ZERO operation.

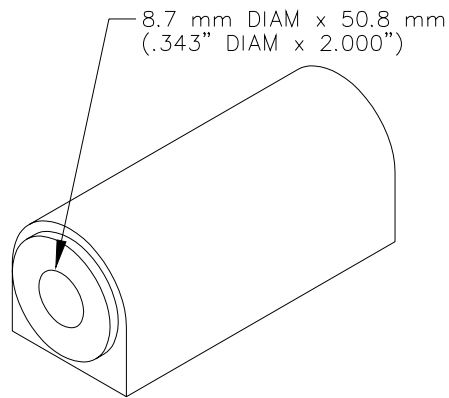

Figure 2-4
Zero Flux Chamber

Section 3

Operating Instructions

OPERATOR SAFETY



Do not connect the auxiliary power connector to an ac power source. Do not exceed 15 Vdc regulated or 9 Vdc unregulated. Do not reverse polarity. Use only a regulated ac-to-dc power supply certified for country of use.

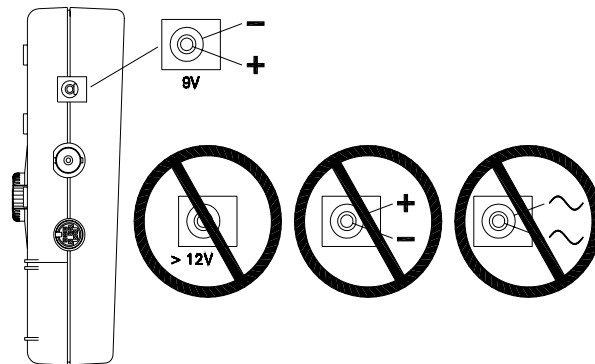

Figure 3-1
Auxiliary Power Connector Warnings

OPERATING INSTRUCTIONS



Do not allow the probe to come in contact with any voltage source greater than 30 Vrms or 60 Vdc.

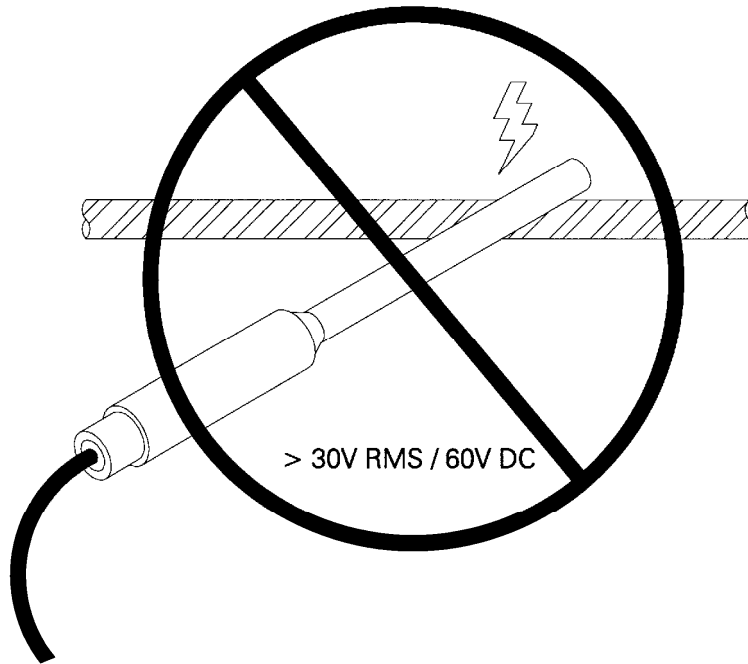

Figure 3-2
Probe Electrical Warning



Batteries contain ferrous materials that are attracted to magnetic fields. Be careful when operating the instrument near large magnetic fields, as it may move without warning. Extension cables are available to increase the probe cable length, so that the instrument can remain in a safe position with respect to the field being measured with the probe.

OPERATING INSTRUCTIONS

OPERATING FEATURES

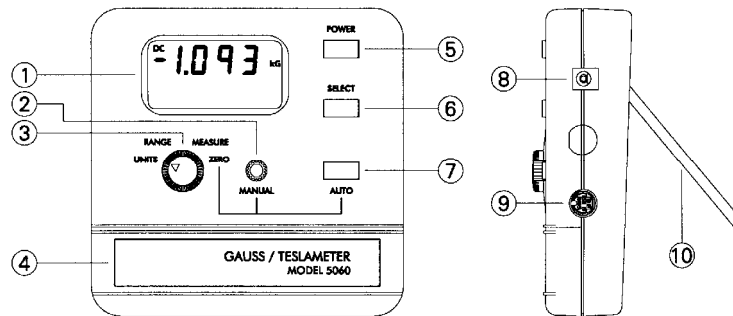

Figure 3-3
Operating Features

- ① **Display.** Liquid crystal display (LCD).
- ② **Manual ZERO Control.** In the ZERO mode of operation the user can manually adjust the zero point using this control.
- ③ **Function Selector.** This control allows the operator to change the meter's range and units of measure. It also engages the ZERO and MEASURE modes of operation.
- ④ **Battery Compartment Cover.** This cover slides open to allow one or two 9 volt batteries to be installed.
- ⑤ **Power Switch.** Push-on / push-off type switch to apply power to the meter.
- ⑥ **SELECT Switch.** Momentary pushbutton used in conjunction with the Function Selector (③) to configure the meter's range and units of measure.

OPERATING INSTRUCTIONS

- ⑦ **AUTO Switch.** Momentary pushbutton used to start an automatic ZERO operation when in the ZERO mode.
- ⑧ **Auxiliary Power Connector.** This is an industry standard 2.5 mm I.D. / 5.5 mm O.D. dc power connector. The meter will accept a regulated dc voltage in the range of 6 - 15 Vdc at 300 mA minimum current or unregulated 9 Vdc. The center pin is positive (+). The internal batteries are disconnected when using this connector.



Do not connect the auxiliary power connector to an ac power source. Do not exceed 15 Vdc regulated or 9 Vdc unregulated. Do not reverse polarity. Use only a regulated ac-to-dc power supply certified for country of use.

- ⑨ **Probe Connector.** The Hall probe or probe extension cable plugs into this connector and locks in place. To disconnect, pull on the body of the plug, not the cable !
- ⑩ **Meter Stand.** Retractable stand that allows the meter to stand upright when placed on a flat surface. A notch in the stand allows the meter to be mounted to a vertical surface.

OPERATING INSTRUCTIONS

INSTRUMENT PREPARATION

- 1) With the power switch turned off (POWER pushbutton in the full up position) apply pressure to the battery compartment cover at the two points shown in Figure 3-4. Slide the cover open and remove.
- 2) Install one or two 9 volt alkaline batteries (two batteries will provide longer operating life). The battery compartment is designed so that the battery polarity cannot be reversed. Reinstall the battery compartment cover.

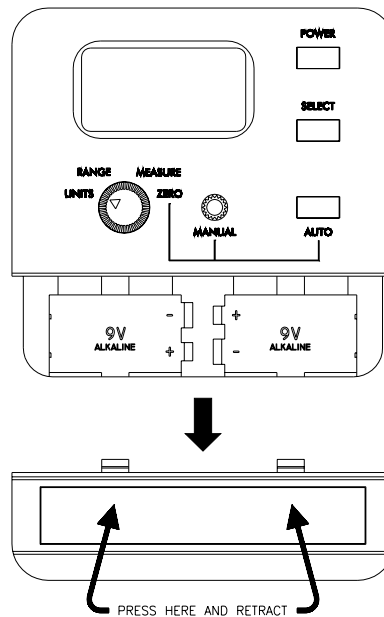

Figure 3-4
Battery Installation

OPERATING INSTRUCTIONS

- 3) If using an ac-to-dc power supply review Figure 3-1 for safety notes and the *SPECIFICATIONS* section for voltage and current ratings. When using a power supply the batteries are automatically disconnected.
- 4) Install the probe or probe extension cable by matching the key way in the connector to that in the mating socket in the meter. The connector will lock in place. To disconnect, pull on the body of the plug, not the cable!

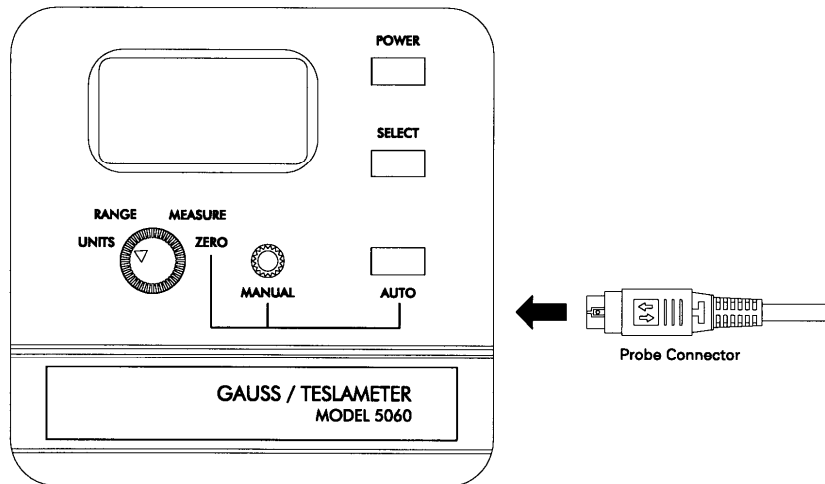

Figure 3-5
Probe Connection

OPERATING INSTRUCTIONS

POWER-UP

Depress the POWER switch. There will be a momentary audible beep and all display segments will appear on the display.

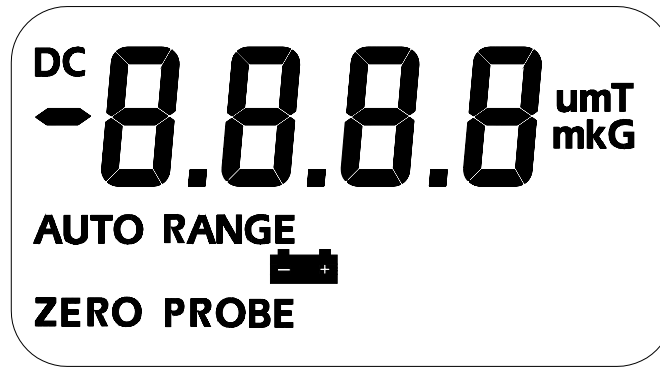

Figure 3-6
Power-Up Display

The instrument will conduct a self test before measurements begin. If a problem is detected the phrase "Err" will appear on the display followed by a 3-digit code. The circuitry that failed will be retested and the error code will appear after each failure. This process will continue indefinitely or until the circuitry passes the test. A condition in which a circuit fails and then passes should not be ignored because it indicates an intermittent problem that should be corrected.

If the self test is successful the meter will perform a self calibration. During this phase the meter will display the software revision number, such as "r 1.0". Calibration will halt if there is no Hall probe connected. Until the probe is connected the phrase "Err" will appear accompanied by a flashing "PROBE" annunciator as shown in Figure 3-7.

OPERATING INSTRUCTIONS

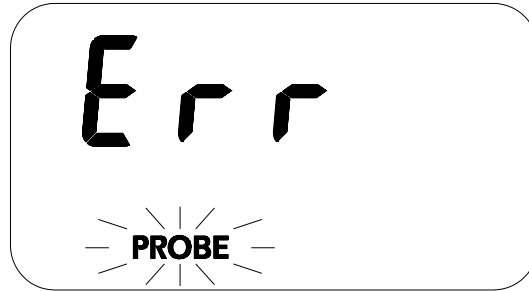

Figure 3-7
Missing Probe Indication

After power-up the position of the FUNCTION selector switch will determine what happens next. For instance if the selector is in the RANGE position the meter will wait for the user to change the present range. If in the MEASURE position flux density measurements will begin.

Allow adequate time for the meter and probe to reach a stable temperature. See the *SPECIFICATIONS* section for specific information.

POWER-UP SETTINGS

The meter permanently saves certain aspects of the instrument's setup and restores them the next time the meter is turned on. The conditions that are saved are:

- RANGE setting
- UNITS of measure (gauss or tesla)

Other aspects are not saved and default to these conditions:

- ZERO mode (inactive)

OPERATING INSTRUCTIONS

NOTE: The present setup of the instrument is saved only when the FUNCTION selector is returned to the MEASURE position. For example assume the meter is in the MEASURE mode on the 200 mT range. The FUNCTION selector is now turned to the RANGE position and the 2 T range is selected. The meter is turned off and on again. The meter will be restored to the 200 mT range because the FUNCTION selector was never returned to the MEASURE mode prior to turning it off.

LOW BATTERY CONDITION

The meter is designed to use one or two standard 9V alkaline batteries (two batteries will provide longer operating life). When the battery voltage becomes too low the battery symbol on the display will flash, as shown in Figure 3-8. Replace the batteries or use an external ac-to-dc power supply.



Instrument specifications are not guaranteed when a low battery condition exists !



Figure 3-8
Low Battery Indication

OPERATING INSTRUCTIONS

OVERRANGE CONDITION

If the magnitude of the magnetic flux density exceeds the limit of the selected range the meter will display a flashing value of "1999". The next highest range should be selected. If already on the highest range then the flux density is too great to be measured with this instrument.

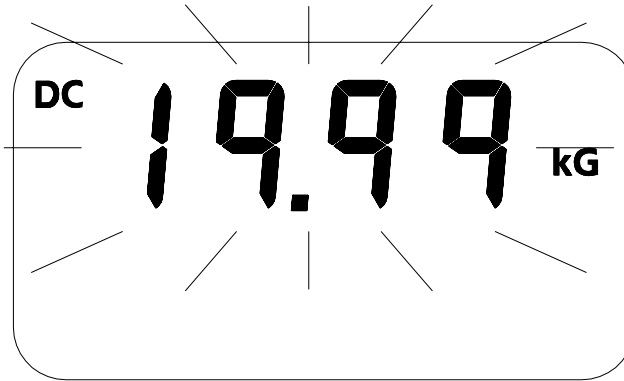

Figure 3-9
Overrange Indication

OPERATING INSTRUCTIONS

UNITS OF MEASURE SELECTION

The meter is capable of providing flux density measurements in terms of gauss (G) or tesla (T). To choose the desired units, rotate the function selector to the UNITS position. Press the SELECT pushbutton to select G or T on the display.

This setting is saved and will be restored the next time the meter is turned on.

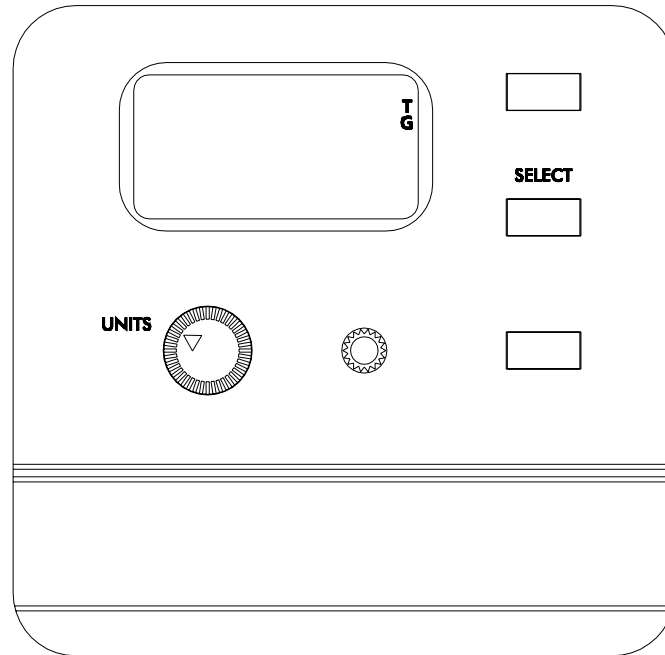

Figure 3-10
UNITS Function

OPERATING INSTRUCTIONS

RANGE SELECTION

The meter is capable of providing flux density measurements on one of two fixed ranges. The available ranges are listed in the *SPECIFICATIONS* section of this manual. The ranges advance in decade steps. The lowest range offers the best resolution while the highest range allows higher flux levels to be measured.

To choose the desired range rotate the function selector to the RANGE position. The "RANGE" legend will flash. Press the SELECT pushbutton to select the desired range on the display.

This setting is saved and will be restored the next time the meter is turned on.

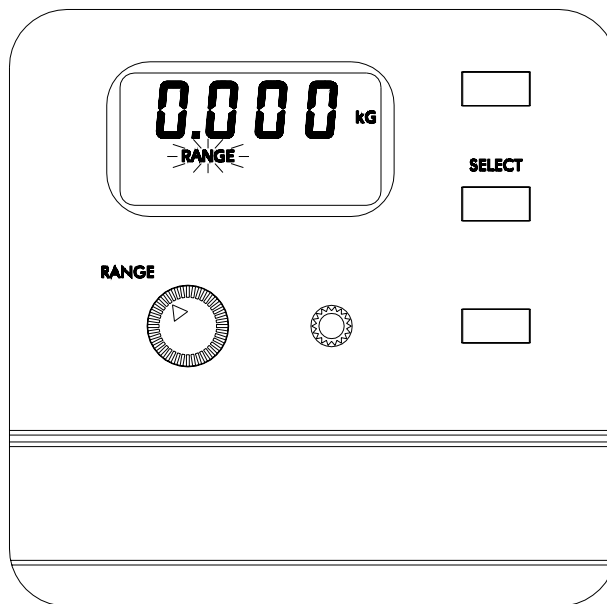

Figure 3-11
RANGE Function

OPERATING INSTRUCTIONS

ZERO FUNCTION

“Zeroing” the probe and meter is one of the most important steps to obtaining accurate dc flux density measurements. The ideal Hall generator produces zero output in the absence of a magnetic field, but actual devices are subject to variations in materials, construction and temperature. Therefore most Hall generators produce some output even in a zero field. This will be interpreted by the meter as a flux density signal.

Also, the circuits within the meter can produce a signal even when there is no signal present at the input. This will be interpreted as a flux density signal. Lastly magnetic sources close to the actual field being measured, such as those from electric motors, permanent magnets and the earth (roughly 0.5 gauss or 50 μ T), can induce errors in the final reading.

It is vital to remove these sources of error prior to making actual measurements. The process of “zeroing” removes all of these errors in one operation. The meter cancels the combined dc error signal by introducing another signal of equal magnitude with opposite polarity. After zeroing the only dc signal that remains is that produced by the probe when exposed to magnetic flux.

NOTE: Zeroing the meter and probe affects only the static (dc) component of the flux density signal.

There may be situations when the user prefers to shield the probe from all external magnetic fields prior to zeroing. Provided with the meter is a ZERO FLUX CHAMBER which is capable of shielding against fields as high as 30 mT (300 G). The probe is simply inserted into the chamber before the zeroing process begins.

OPERATING INSTRUCTIONS



Handle the Hall probe with care. Do not bend the stem or apply pressure to the probe tip as damage may result.

In other situations the user may want the probe to be exposed to a specific magnetic field during the zeroing process so that all future readings do not include that reading (such as the earth's field). This is possible with the following restrictions:

- 1) The external field must not exceed 30 mT (300 G).
- 2) The field must be stable during the zeroing process. It should not contain alternating (ac) components.

AUTOMATIC ZERO FUNCTION

The meter provides two methods to zero the probe. The first is completely automatic. Prepare the probe for zeroing, then rotate the function selector to the ZERO position. The "ZERO" legend will flash and actual dc flux density readings will appear on the display. The meter will select the lowest range regardless of which range was in use prior to using the ZERO function. Recall that the maximum flux density level that can be zeroed is 30 mT (300 G).

OPERATING INSTRUCTIONS

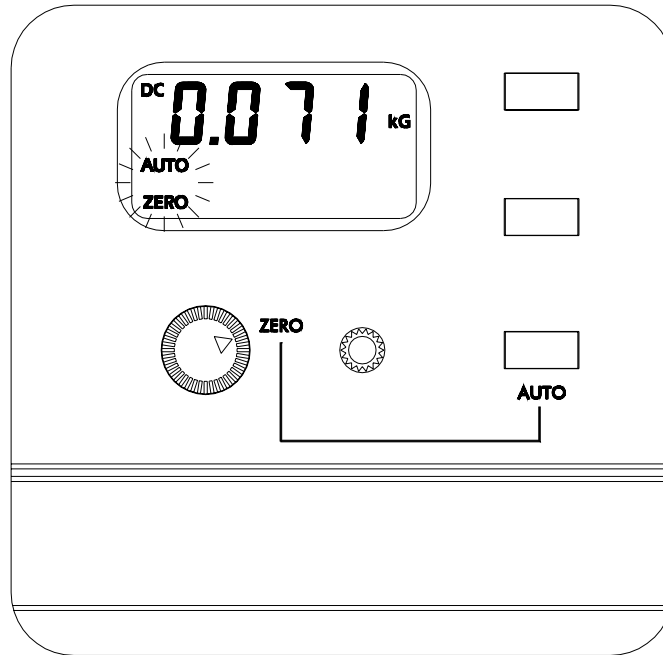

Figure 3-12
Automatic ZERO Function

Press the AUTO pushbutton and the process will begin. The "AUTO" legend will also flash. Once automatic zeroing begins it must be allowed to complete. During this time all controls are disabled except for the POWER switch. The process normally takes from 5 to 15 seconds.

The meter selects the lowest range and adjusts the nulling signal until the net result reaches zero. If the existing field is too large or unstable the meter will sound a double beep and the phrase "OVER" will appear momentarily on the display. At this point the automatic process is terminated and the flashing "AUTO" legend

OPERATING INSTRUCTIONS

will disappear. The “ZERO” legend will continue to flash to remind the user that the ZERO mode is still active.

If the nulling process is successful, the highest range is selected. No further electronic adjustments are made, but at this stage a reading is acquired which will be mathematically subtracted from all future readings on this range. When finished, the meter will sound an audible beep and the flashing “AUTO” legend will disappear. The “ZERO” legend will continue to flash to remind the user that the ZERO mode is still active. At this point the automatic process can be repeated or a manual adjustment can be performed (see “Manual Zero Function”).

The final zero values will remain in effect until the meter and probe are zeroed again, if the probe is disconnected or if the meter is turned off and back on again.

MANUAL ZERO FUNCTION

The second zeroing method is a manual adjustment. This feature also allows the user to set the “zero” point to something other than zero, if desired. Position the probe for zeroing, then rotate the function selector to the ZERO position. The “ZERO” legend will flash and actual dc flux density readings will appear on the display. The meter will select the lowest range regardless of which range was in use prior to selecting the ZERO function. Recall that the maximum flux density level that can be zeroed is 30 mT (300 G).

OPERATING INSTRUCTIONS

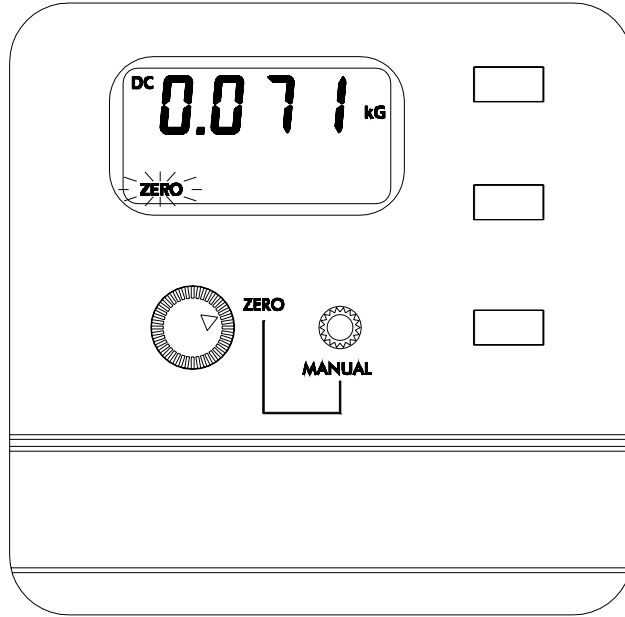

Figure 3-13
Manual ZERO Function

By turning the MANUAL control in either direction the reading will be altered. Turning the control clockwise adds to the reading, turning it counterclockwise subtracts from the reading. Turning it slowly results in a fine adjustment, turning it quickly results in a coarse adjustment.

NOTE: Making a manual ZERO adjustment not only affects the lowest range but also the highest range, though to a lesser extent. For example, assume an automatic ZERO has already been performed, after which both ranges should read zero. Now a manual adjustment is made that causes the reading on the lowest range to be non-zero. The reading on the other range may also

OPERATING INSTRUCTIONS

be non-zero depending upon the magnitude of the change. The adjustment has 10 times less effect on the highest range.

SOURCES OF MEASUREMENT ERRORS

When making flux density measurements there are several conditions that can introduce errors:

- 1) Operating the meter while the LOW BATTERY symbol appears.



Instrument specifications are not guaranteed when a low battery condition exists !

- 2) Failure to zero the error signals from the meter, probe and nearby sources of magnetic interference.
- 3) Subjecting the probe to physical abuse.



Handle the Hall probe with care. Do not bend the stem or apply pressure to the probe tip as damage may result. Use the protective cover when the probe is not in use.

- 4) One of the most common sources of error is the angular position of the probe with respect to the field being measured. As mentioned in Section-1, a Hall generator is not only sensitive to the number of flux lines passing through it but also the *angle* at which they pass through it. The Hall generator produces the greatest signal when the flux lines are perpendicular to the sensor as shown in Figure 3-14.

OPERATING INSTRUCTIONS

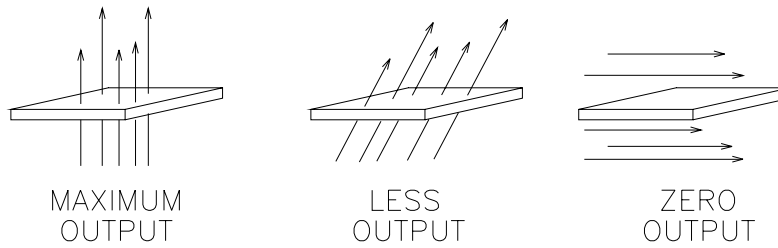

Figure 3-14
Probe Output versus Flux Angle



The probe is calibrated and specified with flux lines passing perpendicularly through the Hall generator.

5) As shown in Figure 3-15 the greater the distance between the magnetic source and the Hall probe the fewer flux lines will pass through the probe, causing the probe's output to decrease.

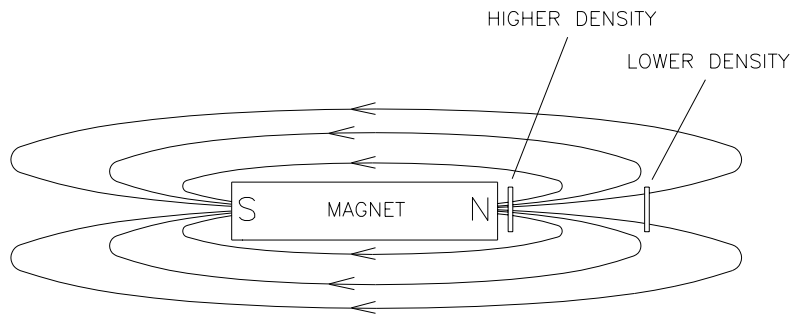

Figure 3-15
Probe Output versus Distance

6) Flux density can vary considerably across the pole face of a permanent magnet. This can be caused by internal physical flaws

OPERATING INSTRUCTIONS

such as hairline cracks or bubbles, or an inconsistent mix of materials. Generally the sensitive area of a Hall generator is much smaller than the surface area of the magnet, so the flux density variations are very apparent. Figure 3-16 illustrates this situation.

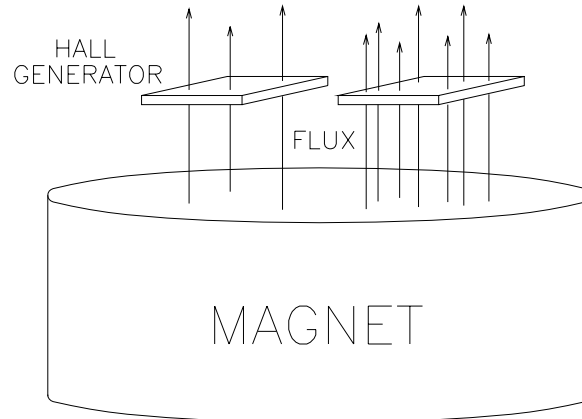

Figure 3-16
Flux Density Variations in a Magnet

7) Using more than one extension cable can result in measurement errors. In some cases the meter may report an error. Total cable length between the meter and the probe connector should not exceed 2.1 m (7 ft).



The use of more than one extension cable can result in measurement errors and increase susceptibility to radio frequency interference (RFI).

8) The accuracies of the probe and meter are affected by temperature changes. Refer to the *SPECIFICATIONS* section for specific information.

WARRANTY

This instrument is warranted to be free of defects in material and workmanship. Sypris Test & Measurement's obligation under this warranty is limited to servicing or adjusting any instrument returned to the factory for that purpose, and to replace any defective parts thereof. This warranty covers instruments which, within one year after delivery to the original purchaser, shall be returned with transportation charges prepaid by the original purchaser, and which upon examination shall disclose to Sypris Test & Measurement's satisfaction to be defective. If it is determined that the defect has been caused by misuse or abnormal conditions of operation, repairs will be billed at cost after submitting an estimate to the purchaser.

Sypris Test & Measurement reserves the right to make changes in design at any time without incurring any obligation to install same on units previously purchased.

THE ABOVE WARRANTY IS EXPRESSLY IN LIEU OF ALL OTHER WARRANTIES EXPRESSED OR IMPLIED AND ALL OTHER OBLIGATIONS AND LIABILITIES ON THE PART OF SYPRIS TEST & MEASUREMENT, AND NO PERSON INCLUDING ANY DISTRIBUTOR, AGENT OR REPRESENTATIVE OF SYPRIS TEST & MEASUREMENT IS AUTHORIZED TO ASSUME FOR SYPRIS TEST & MEASUREMENT ANY LIABILITY ON ITS BEHALF OR ITS NAME, EXCEPT TO REFER THE PURCHASER TO THIS WARRANTY. THE ABOVE EXPRESS WARRANTY IS THE ONLY WARRANTY MADE BY SYPRIS TEST & MEASUREMENT. SYPRIS TEST & MEASUREMENT DOES NOT MAKE AND EXPRESSLY DISCLAIMS ANY OTHER WARRANTIES, EITHER EXPRESSED OR IMPLIED, INCLUDING WITHOUT LIMITING THE FOREGOING, WARRANTIES OF MERCHANTABILITY OR FITNESS FOR A PARTICULAR PURPOSE OR ARISING BY STATUE OR OTHERWISE IN LAW OR FROM A COURSE OF DEALING OR USAGE OR TRADE. THE EXPRESS WARRANTY STATED ABOVE IS MADE IN LIEU OF ALL LIABILITIES FOR DAMAGES, INCLUDING BUT NOT LIMITED TO CONSEQUENTIAL DAMAGES, LOST PROFITS OR THE LIKE ARISING OUT OF OR IN CONNECTION WITH THE SALE, DELIVERY, USE OR PERFORMANCE OF THE GOODS. IN NO EVENT WILL SYPRIS TEST & MEASUREMENT BE LIABLE FOR SPECIAL, INDIRECT OR CONSEQUENTIAL DAMAGES EVEN IF SYPRIS TEST & MEASUREMENT HAS BEEN ADVISED OF THE POSSIBILITY OF SUCH DAMAGES.

This warranty gives you specific legal rights, and you may also have other rights that vary from state to state.

THIS SHEET BLANK !

(Back of Warranty)

THIS SHEET BLANK !

THIS SHEET BLANK !

THIS SIDE BLANK !

(Inside of back cover)



6120 Hanging Moss Road
Orlando, FL 32807
Phone: 407-678-6900
Fax: 407-677-5765

