

**OPERATING AND MAINTENANCE
INSTRUCTIONS
FOR
TYPE 1800-A
VACUUM-TUBE VOLTMETER**

FORM 653-D



**GENERAL RADIO COMPANY
CAMBRIDGE 39, MASSACHUSETTS**

TABLE OF CONTENTS

	<i>Page</i>
INTRODUCTION	1
SECTION 1.0—OPERATING CONTROLS AND PROCEDURE	1
1.1 Instrument Support	1
1.2 Mechanical Zero	1
1.3 Power Supply	2
1.4 Electrical Zero	2
1.5 D-C Voltage Measurements	3
1.6 A-C Voltage Measurements	4
SECTION 2.0—CIRCUIT AND CONSTRUCTION	5
2.1 General Construction	5
2.2 Probe	5
2.3 Probe Fittings	6
2.4 D-C Amplifier	6
2.5 Indicating Meter	7
2.6 Zero Controls	7
2.7 Degeneration	7
2.8 Power-Supply Stabilization	7
2.9 Reconnecting Power Transformer for Different Line Voltage	7
SECTION 3.0—OPERATING CHARACTERISTICS	8
SERVICE AND MAINTENANCE NOTES	10
VACUUM-TUBE DATA	15
PARTS LIST	16
WIRING DIAGRAM	18

Price 50 cents

**OPERATING AND MAINTENANCE
INSTRUCTIONS
FOR
TYPE 1800-A
VACUUM-TUBE VOLTMETER**

FORM 653-D



**GENERAL RADIO COMPANY
CAMBRIDGE 39, MASSACHUSETTS
NEW YORK CHICAGO LOS ANGELES
U. S. A.**

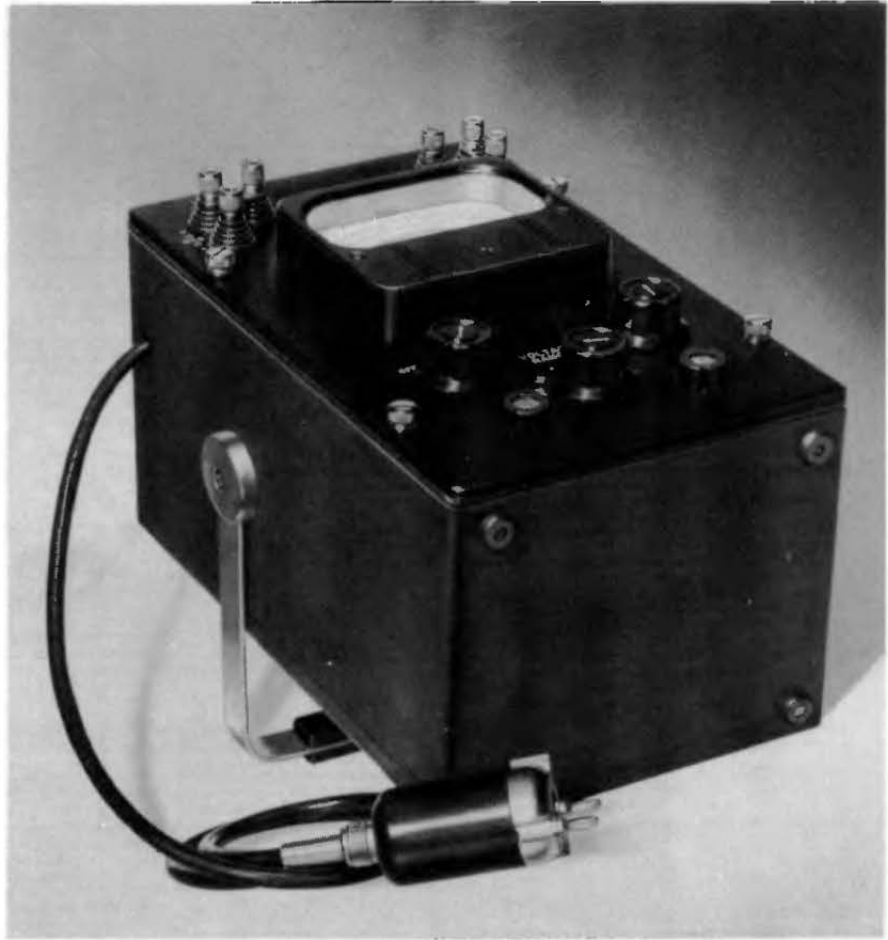

Figure 1. Panel view of the Type 1800-A Vacuum-Tube Voltmeter (left) with handle in vertical carrying position, and (right) with the handle locked in position for supporting instrument with inclined panel.

OPERATING AND MAINTENANCE INSTRUCTIONS FOR TYPE 1800-A VACUUM-TUBE VOLTMETER

INTRODUCTION

The Type 1800-A Vacuum-Tube Voltmeter is a high-impedance voltmeter incorporating both a-c and d-c ranges for voltages up to 150 volts. The upper frequency limit of the a-c ranges is in the vicinity of 500 Mc.

On the a-c voltage ranges, except for the two lowest, it is essentially a peak-reading instrument, but the scales are calibrated to give readings of the r-m-s value of sinusoidal applied voltages.

The circuit is shown in elementary form in the Elementary Schematic Diagram, Figure 2. A complete circuit diagram is shown in Figure 7, at the back of this book.

Mechanically the voltmeter is small, compact, and convenient to use, while the chassis construction makes all component parts easily available for servicing.

SECTION 1.0 OPERATING CONTROLS AND PROCEDURE

1.1 INSTRUMENT SUPPORT

The walnut cabinet is provided with a handle that can be used to support the instrument in an inclined position. The handle locks into position for carrying the instrument and into the support position. Figure 1 shows the handle in the two positions. It is released by pressing in on the handle near each hub.

1.2 MECHANICAL ZERO

Before turning on the power, check and reset if necessary the mechanical zero on the meter.

GENERAL RADIO COMPANY

1.3 POWER SUPPLY

Be sure that the line voltage and frequency correspond to those on the plate under the power input socket. The power transformer primaries can be connected for either 115-volt or 230-volt operation. Section 2.9 details the changes in connections for converting from one voltage to the other. The plate indicates the voltage for which the instrument was connected when shipped. If changes are made, the plate should be reversed. One side is stamped for 115 volts, the other for 230 volts.

1.31 Connect the instrument to the a-c line with the cord and plug assembly provided.

1.4 ELECTRICAL ZERO

Fasten the connecting link across the OPEN GRID D-C terminals. Turn the OFF-A.C.-D.C. switch to D.C. and allow the instrument to warm up for about five minutes. Turn the VOLTAGE RANGE switch to 0.5 and adjust the meter reading to zero with the panel ZERO control. Turn the OFF-A.C.-D.C. switch to A.C. Short-circuit the HIGH and LOW A-C terminals. The meter reading should be approximately zero.

1.41 It is likely that over a period of time the a-c zero will drift out of exact coincidence with the d-c zero. If this happens, the coincidence can be restored by adjustment of the A-C ZERO adjustment, or the meter reading may be set to zero by means of the panel ZERO control. In the latter case the d-c and a-c zeros will not coincide. This causes no harm beyond the inconvenience involved. (See also Section 2.6).

1.42 The panel ZERO control may be centered if necessary by use of the COARSE ZERO adjustment on the bottom of the chassis.

1.43 If the OPEN GRID D-C terminals are used and the 10 MEG Ω terminals short-circuited, the zero can not be adjusted unless the voltage source is connected to the terminals with the voltage at zero, or unless a resistance, which for high accuracy should be equal to the voltage source resistance, is connected to the terminals.

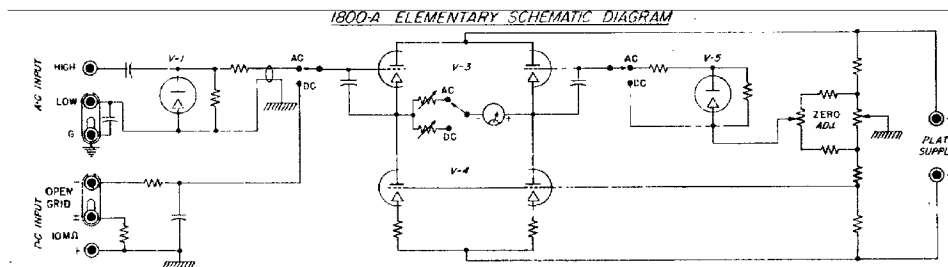

Figure 2. Schematic diagram of Type 1800-A Vacuum-Tube Voltmeter.

TYPE 1800-A VACUUM-TUBE VOLTMETER

1.5 D-C VOLTAGE MEASUREMENTS

1.51 Polarity—In the case where the negative side of the voltage being measured is grounded, be sure that the LOW A-C terminal is not connected to the ground terminal, G. The +D-C terminal and the LOW A-C terminal are common.

1.52 Ground—It is usually desirable to ground the panel at G.

1.53 Range Switch—Set RANGE switch to desired full-scale value.

1.54 Input Resistance—For d-c voltage measurements, two values of input resistance, 10 MEG Ω and OPEN GRID are provided. A link is provided to short-circuit the resistance that is not used.

The OPEN-GRID resistance is determined by the insulation resistance and by the flow of grid current through the voltage source. The resistance caused by the flow of grid current varies with the voltage being measured:

$$R = \frac{E}{I_g}$$

where $I_g = 1.5 \times 10^{-9}$ amp. or less

E = voltage being measured

R = input resistance because of I_g

1.55 Zero Reading—The zero reading depends upon the value of the source resistance of the voltage being measured, for grid current from the d-c amplifier tube, V-3, flows through whatever resistance is across the input terminals. In order to obtain highest accuracy the zero should be adjusted with a resistance that is equal to the source resistance placed across the input terminals.

1.56 Adjustment for Minimum Error—If the parallel combination of source resistance and input resistance does not differ by more than 1 megohm from the resistance across the terminals when the zero is adjusted, the error caused by change in zero when the source is connected to the terminals will not exceed 0.5% of the full-scale reading on the 0.5-volt range.

If the VOLTAGE RANGE switch is turned to the 0.5-volt position immediately after the instrument has been used to measure a high voltage, the meter pointer may be somewhat slow in returning to zero. Although the lumped capacitance values were chosen to give a low time constant, interfacial polarization in the dielectrics of the distributed capacitances of the probe, cable, and associated circuits causes the charge stored in these distributed capacitances to decay slowly. As the discharge takes place through the high resistances in the probe, this slow decay makes the meter pointer drop slowly. The effect becomes most noticeable as the discharge, and therefore the meter pointer, nears zero.

GENERAL RADIO COMPANY

1.57 Correction—When the source resistance is high, correction should be made for the voltage-dividing effect of the input resistance. The true source voltage may be obtained from

$$E_{\text{source}} = E_{\text{indicated}} \times \frac{R_{\text{source}} + R_{\text{input}}}{R_{\text{input}}}$$

1.6 A-C VOLTAGE MEASUREMENTS

1.61 Probe—A-C voltages to be measured may be applied either directly to the probe terminals or to the panel A-C terminals with the probe plugged into position in the compartment at the top of the cabinet. When the panel input terminals are used, the capacitance loading and the frequency error are greater than when the voltage is applied directly to the probe. Because of this, it is advisable to connect directly to the probe when measuring high-frequency voltages.

The probe may be used with or without the end cap. The input capacitance is about 1 μf lower when the cap is off. When the cap is on the probe, the terminals provided are either the GR Type 274 Plug Terminals or the GR Type 774 Coaxial Terminals. A 50-ohm terminating resistor is supplied for use with the Type 774 terminals. For high-frequency measurements where a minimum-inductance connection is desired, the cap may be fastened to a flat ground plate that has a hole giving access to the high terminal.

1.62 Polarity and Grounding—If the a-c voltage being measured is at some d-c potential above ground, the LOW A-C terminal should be disconnected from the G terminal.

It is usually advisable to ground the panel at G.

Figure 3. Exploded view of the voltmeter probe including Type 274 and Type 774 terminations and 50-ohm terminating resistor.

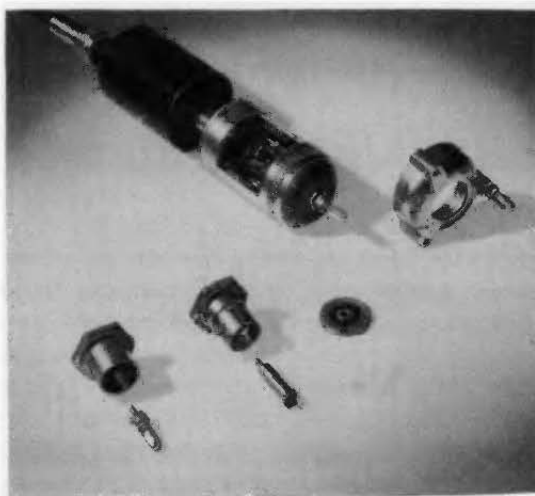

TYPE 1800-A VACUUM-TUBE VOLTMETER

1.63 D-C Potential—The maximum d-c voltages which may be applied across the probe terminals are: positive polarity to HIGH terminal, 300 volts; negative polarity to HIGH terminal, 700 volts.

The maximum d-c voltage which may be applied from the LOW A-C terminal to ground is 500 volts.

1.64 A-C Meter Scales—The two outer scales, which are linear, are used both for d-c voltages and for a-c voltages greater than 5 volts. The three non-linear inner scales are used only for a-c voltage measurements.

A mirror has been located between the inner and outer groups of scales. The mirror does not increase the accuracy of the instrument, but it does make it possible to read the voltage more precisely. The extra precision of reading or setting is especially important when small differences must be observed. The upper portion of the pointer has been made knife-edged to facilitate further the precise observation of small differences. The lower portion has been made broad so that the approximate position of the pointer can be seen from some distance away.

Small differences must often be observed in an a-c voltage that is not properly read on one of the linear scales under the knife-edged portion of the pointer. If the voltage is above about 0.5 volt, the difference can be observed on the corresponding linear scale with only a small error. For voltages less than about 0.5 volt, the difference read on the linear scale must be corrected for the non-linearity of the a-c scale. Of course, the actual voltage level, if it must be known, should be read on the correct a-c scale.

SECTION 2.0 CIRCUIT AND CONSTRUCTION

2.1 GENERAL CONSTRUCTION

In order to have an instrument that can be easily handled and that occupies a minimum of bench space, the Type 1800-A Vacuum-Tube Voltmeter has been made as compact as possible. The tubes, with the exception of V-1, and most of the circuit components are mounted on a chassis that is attached to the panel on four insulating supports. The cable connection between the chassis and the panel is arranged so that the chassis can be detached and swung to one side. This makes all circuit components easily accessible for servicing.

2.2 PROBE

The small shielded probe contains the diode rectifier. It is of cylindrical construction with a rotating metal cover provided to close the opening through which the acorn-tube diode is inserted. When this opening is closed, the probe

GENERAL RADIO COMPANY

is completely shielded except for a small area of insulation at the front.

A metal cap that is used to attach the various fittings described below screws onto the end of the probe. The body of the probe behind the end cap is insulated by a phenolic cover that slips in place and is secured by an insulated nut.

When it is not desired to connect the a-c voltage directly to the probe, the probe can be inserted into the back of the a-c terminals on the panel and the a-c voltage can be applied to those terminals.

A three-wire shielded cable between the probe and the chassis connects the rectifier circuit to the d-c amplifier circuit.

2.3 PROBE FITTINGS

The probe fittings are stored in the compartment at the top of the cabinet. They consist of three Type 274 Plugs, both male and female Type 774 Coaxial Terminals, and a 50-ohm, concentric, terminating resistor. These fittings are attached by the metal cap that screws onto the end of the probe.

2.4 D-C AMPLIFIER

The d-c amplifier consists of two balanced triodes operating in a highly degenerated circuit. The rectified alternating voltage is applied directly to the control grid of one triode, and a diode that serves only to balance the effect of the initial voltage of the rectifying diode is connected to the control grid of the second triode. Both triodes are contained in one envelope.

Figure 4. View of the storage compartment at the top of the cabinet. The various probe fittings are stored here and the probe itself is placed here when not in use or when the panel A-C terminals are used.

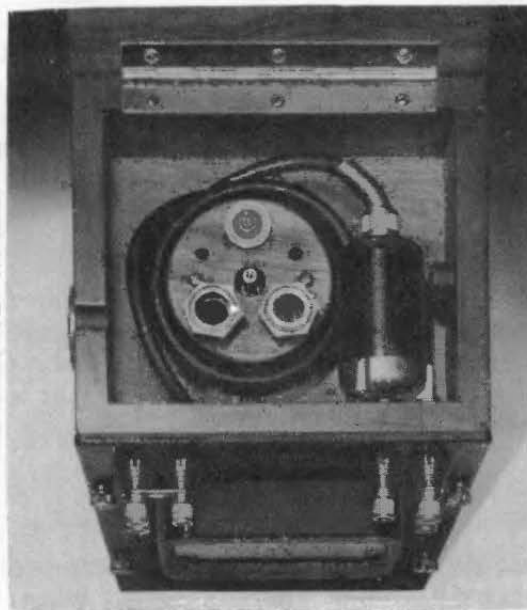

TYPE 1800-A VACUUM-TUBE VOLTMETER

2.5 INDICATING METER

The indicating meter is connected in series with precision resistors between the cathodes of the two triodes. The voltage range of the instrument is changed by changing the value of the series resistance.

2.6 ZERO CONTROLS

There are three zero controls. The fine ZERO control, which is used during normal operation of the instrument, is located on the right-hand side of the panel.

The COARSE ZERO adjustment, which is used to adjust the position of the ZERO control, is located on the bottom of the instrument chassis. A bottom view of the chassis is shown in Figure 8.

The A-C ZERO adjustment, which is used to adjust the a-c zero setting of the panel ZERO control to coincide with the d-c zero setting, is located next to the COARSE ZERO adjustment on the bottom of the chassis.

2.7 DEGENERATION

On the higher voltage ranges the d-c amplifier is highly degenerated. On the lower voltage ranges the degeneration is less because of the decreased value of the resistance in series with the indicating meter. High degeneration without excessive plate voltage requirements is obtained by connecting a degenerated triode in series with the cathode of each amplifier triode. The two degenerated triodes are also contained in one envelope.

2.8 POWER-SUPPLY STABILIZATION

In order to allow satisfactory operation of the instrument at various line voltages, the d-c plate supply and the a-c heater voltages of the two diodes are stabilized. The d-c supply voltage is stabilized with an electronic regulator circuit consisting of two miniature vacuum tubes and two small neon tubes. The diode heater voltages are stabilized by use of a ballast tube.

2.9 RECONNECTING POWER TRANSFORMER FOR DIFFERENT LINE VOLTAGE

The transformer primaries can be connected for either 115-volt or 230-volt operation. The a-c line is connected, through the power switch and fuses, to power transformer terminals No. 17 and No. 20. For 115-volt operation connect terminal No. 17 to terminal No. 19 and terminal No. 18 to terminal No. 20. For 230-volt operation connect terminal No. 18 to terminal No. 19. If the transformer connections are changed from the factory connections, reverse the plate under the power input socket, and replace the two line fuses. (See Parts List.)

GENERAL RADIO COMPANY

SECTION 3.0 OPERATING CHARACTERISTICS

3.01 Voltage Range: 0.1 to 150 volts, a-c, in six ranges (0.5, 1.5, 5, 15, 50 and 150 volts, full scale); 0.01 to 150 volts, d-c, in six ranges (0.5, 1.5, 5, 15, 50 and 150 volts, full scale).

3.02 Accuracy: D-C, $\pm 2\%$ of full scale on all six ranges. A-C, $\pm 2\%$ of full scale on all six ranges for sinusoidal voltages.

3.03 Waveform Error: On the a-c voltage ranges, the instrument operates as a peak voltmeter calibrated to read r-m-s values of a sine wave, or 0.707 of the peak value of a complex wave. On distorted waveforms the percentage deviation of the reading from the r-m-s value may be as large as the percentage of harmonics present.

3.04 Frequency Errors: At high frequencies resonance in the input circuit and transit-time effects in the diode rectifier introduce errors in the meter reading. The resonance effect causes the meter to read high and is independent of the applied voltage. The transit-time error is a function of the applied voltage and tends to cause the meter to read low. The curves of Figure 5 give the frequency correction for several different voltage levels. It will be noted that at low voltages the transit-time and resonance effects tend to cancel, while at higher voltages the error is almost entirely due to resonance. The resonant frequency with cap on but plug removed is about 1050 Mc.

At low frequencies the response drops off because of the increasing reactance of the series capacitance in the input circuit. At 20 cycles per second the drop is 2% or less.

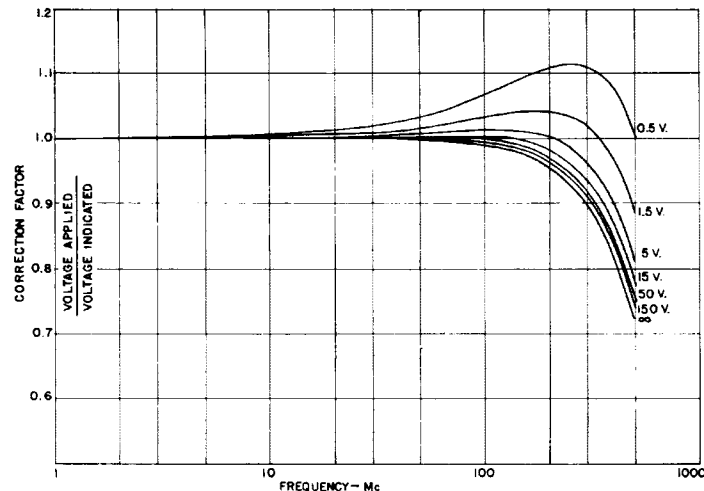

Figure 5. Frequency corrections for a number of different indicated voltages, taken with cap on but plug removed. The curve marked ∞ is included to show the complete resonance effect.

TYPE 1800-A VACUUM-TUBE VOLTMETER

3.05 Input Impedance: The equivalent a-c input circuit is a resistance in parallel with a capacitance. At low frequencies, the equivalent parallel resistance is 25 megohms. At higher frequencies this resistance is reduced by losses in the shunt capacitance. The equivalent parallel capacitance at radio frequencies is $3.1 \mu\mu\text{f}$ with the probe cap and plug removed. At audio frequencies this capacitance increases slightly. The probe cap and plug add approximately $1.2 \mu\mu\text{f}$. Figure 6 gives the variation of R_p and X_p with frequency.

On the d-c ranges the input resistance is either 10 megohms or open grid, depending on the terminals used.

3.06 Power Supply: 105 to 125 volts or 210 to 250 volts, a-c, 50 to 60 cycles. The instrument incorporates a voltage regulator to compensate for supply variations over this voltage range. The power input is less than 25 watts.

3.07 Tubes: Two Type 9005, two Type 6SL7-GT, one Type 6AT6, one Type 6C4, one Type 6X5-GT, one Type 3-4, and two Type 991 are used; all are supplied.

3.08 Accessories Supplied: A seven-foot line connector cord, spare fuses, Type 274 and Type 774 terminations and 50-ohm terminating resistor for probe.

3.09 Mounting: Black crackle finish aluminum panel mounted in a shielded walnut cabinet.

3.10 Dimensions: (Width) $7\frac{3}{8}$ " x (depth) $7\frac{1}{2}$ " x (height) $11\frac{1}{8}$ ", over-all.

3.11 Net Weight: 13 pounds.

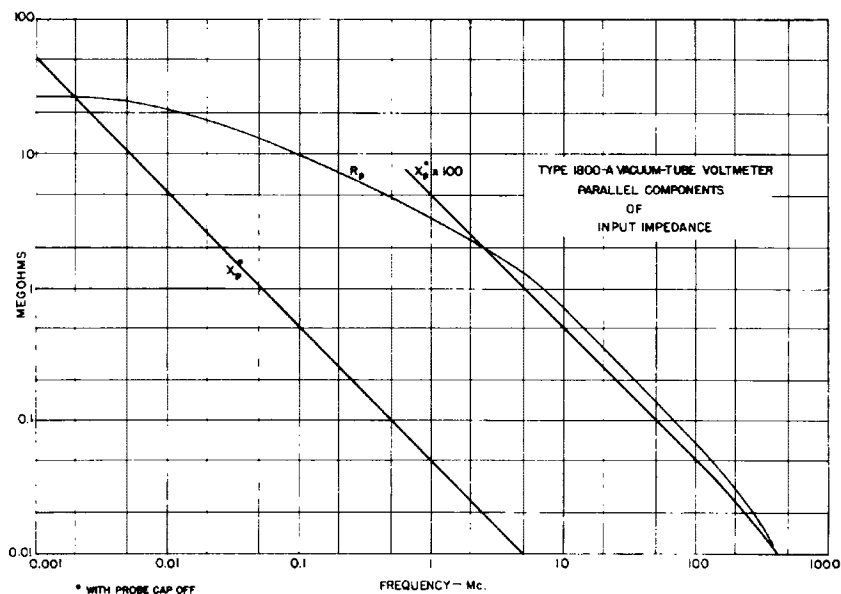

Figure 6. Plot of impedance versus frequency for the parallel components of input impedance. The equivalent parallel capacitance is $3.1 \mu\mu\text{f}$.

GENERAL RADIO COMPANY

SERVICE AND MAINTENANCE NOTES FOR THE TYPE 1800-A VACUUM-TUBE VOLTMETER

1.0 FOREWORD

1.1 This Service Information together with the information given in the Operating Instructions should enable the user to locate and correct difficulties resulting from normal usage.

1.2 Most of the components mentioned in these notes can be located by referring to the photographs.

1.3 Major service problems should be referred to the Service Department which will cooperate as far as possible by furnishing information and instructions, as well as by shipping any replacement parts which may be required. If the instrument is more than one year old, a reasonable charge may be expected for replacement parts or for complete reconditioning and recalibration if the voltmeter is returned.

1.4 Detailed facts giving type and serial numbers of the instrument and parts, as well as operating conditions, should always be included in your report to the Service Department.

2.0 GENERAL

If the voltmeter becomes inoperative, a few simple checks should be made before removing the instrument from its cabinet.

2.1 Check the power line source for proper voltage and frequency.

2.2 Test the power-supply cord for an open circuit or for poor contact in the power socket.

2.3 Check the fuses mounted on the panel for open circuits, and be sure they are tight in their clips.

3.0 VOLTMETER DOES NOT OPERATE PROPERLY

3.1 See that all tube filaments are lighted.

3.2 Meter lamps do not light, refer to Section 4.0

3.3 Meter does not move up scale and return to zero when the voltmeter is turned on with VOLTAGE RANGE switch set to 0.5, refer to Section 5.0.

3.4 Unable to set to "0" with ZERO control, voltmeter set to D-C, refer to Section 6.0.

3.5 Unable to set to "0" with ZERO control, voltmeter set to A-C, refer to Section 7.0.

3.6 Meter does not read with D-C signal applied to the 10 MEG Ω input terminals, refer to Section 8.0.

3.7 Meter does not read with D-C signal applied to the OPEN GRID input terminals, refer to Section 9.0.

TYPE 1800-A VACUUM-TUBE VOLTMETER

3.8 Meter does not read with an A-C signal applied to input terminals, refer to Section 10.0.

3.9 Meter reads incorrectly on one or more voltage ranges, refer to Section 11.0.

3.10 Recalibration, refer to Section 12.0.

3.11 Power supply inoperative or has low output voltage, refer to Section 13.0.

3.12 Replacement of components, refer to Section 14.0.

3.13 Vacuum-tube data, refer to Section 15.0.

4.0 METER LAMPS DO NOT LIGHT

4.1 Test fuses F-1 and F-2 for open circuits.

4.2 Check lamps P-1 located in meter case.

4.3 Check contacts and operation of power switch S-2.

4.4 Check connections to and continuity of transformer T-1.

5.0 METER DOES NOT MOVE UPSCALE AND RETURN TO ZERO WHEN THE VOLTMETER IS TURNED ON WITH VOLTAGE RANGE SWITCH SET TO 0.5.

5.1 Check tube V-3 and operating voltages.

5.2 Check operation of switch S-1.

5.3 Check resistors R-10 and R-11 for open and short circuits.

5.4 Check condensers C-2 and C-3 for open and short circuits.

5.5 Defective meter M-1.

5.51 Nominal sensitivity is 100 microamperes d.c. for full scale deflection. See Section 11.11.

5.52 If the meter is defective, a replacement should be ordered from the Service Department. The General Radio Company cannot assume responsibility for any local repairs to the meter, although such repairs may be necessary in an emergency.

5.6 Check tube V-4 and operating voltages.

5.7 Check resistors R-29, R-30, R-36, R-37, R-38 and R-39 for open and short circuits.

5.8 Check resistors R-12, R-13, R-21 and R-22 for continuity.

5.9 Check switch S-3 for continuity and proper operation.

6.0 UNABLE TO SET METER TO "O" WITH ZERO CONTROL, VOLTMETER SET TO D-C

6.1 Check the d-c voltage between B+ and B- to be 450 volts ± 5.0 volts. Refer to Section 13.5.

6.2 Check resistors R-33, R-34 and R-35 for open and short circuits. Refer to Sections 5.7 and 5.8.

GENERAL RADIO COMPANY

6.3 Check that tube V-3 has low grid current. This can be done by the following procedure.

6.31 Set the switches for the 0.5-volt d-c range.

6.32 Place the connecting link across the D-C OPEN GRID terminals.

6.33 Adjust the meter to zero with the ZERO control or the COARSE ZERO adjustment.

6.34 Short circuit the D-C 10 MEG Ω terminals. The meter reading should not be more than .015 volt.

6.35 Remove ballast tube V-2 from its socket.

6.36 With the short circuits still across both sets of D-C terminals, adjust the meter to read 0.2 volt using either the ZERO control or the COARSE ZERO adjustment.

6.37 Turn switch S-1 to A-C. The meter should not vary by more than ten scale divisions above or below the 0.2-volt reading. The reading should stabilize within a few seconds and the meter should show no drift.

6.38 If the tube fails to pass any of the above tests it should be rejected in favor of another tube.

7.0 UNABLE TO SET TO "0" WITH ZERO CONTROL, VOLTMETER SET TO A-C.

7.1 Refer to *Sections 6.1 and 13.5*.

7.2 Check tube V-1 and operating voltages, refer to Section 14.1.

7.3 Check that the cathode of V-1 is grounded to the shell of the probe.

7.4 Check resistors R-1 and R-2 for open and short circuits.

7.5 Check tube V-2 for continuity and operating voltages.

7.6 Check resistors R-5 through R-9.

7.7 Check tube V-5 and operating voltages.

7.8 Check resistors R-31 and R-32 for open and short circuits.

7.9 Check operation of switch S-1.

7.10 If it is necessary to replace either or both V-1 and V-5, follow the procedure of Section 1.4 of the Operating Instructions, trying various tubes until tubes are found which will permit a satisfactory zero adjustment.

8.0 METER DOES NOT READ WITH D-C SIGNAL APPLIED TO THE 10 MEG Ω INPUT TERMINALS

8.1 Be sure that the connecting link is shorting the OPEN GRID terminals.

8.2 Check resistor R-4 for a short circuit.

8.3 Check resistor R-51 for an open circuit.

8.4 Check condenser C-7 for a short circuit.

8.5 Refer to *Section 5.0*.

9.0 METER DOES NOT READ WITH D-C SIGNAL APPLIED TO THE OPEN GRID INPUT TERMINALS

9.1 Be sure that the connecting link is shorting the 10 MEG Ω terminals.

9.2 Refer to *Sections 5.0, 8.3, and 8.4*.

TYPE 1800-A VACUUM-TUBE VOLTMETER

10.0 METER DOES NOT READ WITH A-C SIGNAL APPLIED TO INPUT TERMINALS

- 10.1 Check condenser C-1 for an open or a short circuit.
- 10.2 Refer to *Sections 5.0 and 7.0*

11.0 METER READS INCORRECTLY ON ONE OR MORE VOLTAGE RANGES

- 11.1 Check meter sensitivity.

11.11 Full scale sensitivity of the meter, shunted by R-52, is 102 micro-amperes dc. R-52 is picked in the standardizing laboratory to provide this value of sensitivity. Refer to *Section 5.5*.

11.2 D-C measurements:

- 11.21 Check resistors R-21 through R-28.
- 11.22 Try changing tube V-3. Refer to *Section 6.3*.

11.3 A-C measurements:

- 11.31 Check resistors R-12 through R-20.
- 11.32 Try changing tubes V-1, V-3 and V-5. Refer to *Sections 6.3 and 7.10*.
- 11.4 Check calibration of 0.5 and 1.5 volt VOLTAGE RANGE. Refer to *Section 12.0*.

12.0 RECALIBRATION

12.1 Accurately known sources of a-c and d-c voltages should be available before attempting any recalibration of this instrument.

12.2 Check zero adjustments, refer to *Section 7.10* of these Notes and Section 1.4 of the Operating Instructions.

- 12.3 Refer to *Section 6.1* and *13.5*.

12.4 D-C Calibration

12.41 Set VOLTAGE RANGE switch to the 0.5- and 1.5-volt positions and apply the corresponding d-c voltage to the D-C 10 MEG Ω input terminals with the connecting link shorting the OPEN GRID terminals.

12.42 Set the meter to full scale by means of potentiometer R-22 for the 0.5-volt range and potentiometer R-23 for the 1.5-volt range. These are marked D. C. CAL, 0.5 v and 1.5 v, respectively, on the bottom subpanel.

12.5 A-C Calibration:

12.51 Set VOLTAGE RANGE switch to the 0.5- and 1.5-volt positions and apply the corresponding sine-wave, root-mean-square, a-c voltages to the A-C input terminals.

12.52 Set the meter to full scale by means of potentiometer R-13 for the 0.5-volt range and potentiometer R-14 for the 1.5-volt range. These are marked A.C. CAL, 0.5 v and 1.5 v, respectively, on the bottom subpanel.

GENERAL RADIO COMPANY

13.0 POWER SUPPLY INOPERATIVE OR HAS LOW OUTPUT VOLTAGE

13.1 Check tubes V-6, V-7, V-8, V-9 and V-10 and operating voltages.

13.12 Note that one plate each of V-9 and V-10 glows evenly.

13.2 Check connections to and continuity of transformer T-1.

13.3 Check resistors R-40 through R-50 for open and short circuits.

13.4 Check condensers C-5 and C-6.

13.41 NOTE. The d-c voltage across either one of these condensers should not exceed 425 volts maximum. If the voltage across either condenser exceeds 425 volts the *other* condenser should be replaced, assuming that R-49 and R-50 are not defective.

13.5 The output voltage of the power supply, as measured between B+ (slate-red wire) and B- (yellow-green wire) on the terminal strip on the right side of the instrument above the power receptacle, should be set to 450 volts \pm 5.0 volts, dc, as measured with a 20,000 ohm-per-volt voltmeter.

13.51 Set the input line voltage to 100 volts, ac.

13.52 Adjust potentiometer R-45 until B+ voltage reads 450 volts.

13.53 Increase the line voltage to 130 volts.

13.54 Adjust potentiometer R-43 until B+ again reads 450 volts.

13.55 Repeat the above procedure until the B+ voltage remains constant for any input voltage between 105 and 125 volts.

14.0 REPLACEMENT OF COMPONENTS

Due to the compact design and construction of this instrument and the number of component parts mounted in the available space, a number of mechanical expedients have been used. The following instructions should be followed when replacement of component parts is necessary.

14.1 Probe

14.11 Unscrew spring ring at rear of probe.

14.12 Pull back black phenolic housing.

14.13 Rotate the rotatable metal shield exposing tube V-1.

14.14 Remove tube V-1.

14.15 Unscrew the banana plug probe and the retaining hex nut at the front of the probe.

14.16 Unscrew and remove the three black-headed screws in the retaining plate.

14.17 Remove the retaining plate.

14.18 Remove the snap ring holding the inner assembly in place using a pair of thin, long-nosed pliers to squeeze the ends of the ring together.

14.19 Unscrew the metal cap at the front of the probe and *pull back* the rotatable metal shield.

14.110 Unsolder the joint holding the inner suspension to the metal shell.

TYPE 1800-A VACUUM-TUBE VOLTMETER

14.111 Remove the entire inner assembly by pulling on the cable, being careful not to damage R-1 and R-2 which are now supporting C-1.

14.112 **CAUTION:** When using a soldering iron to replace components, be careful not to overheat the insulating blocks of polystyrene at the front and rear of the inner assembly as these melt at a relatively low temperature.

14.2 Main instrument.

14.21 Remove the four screws that hold the subpanel on which the tubes are mounted to the four bakelite mounting posts.

14.22 Unsolder the two black covered wires that run from the socket of V-3 to switch S-1. These points are marked "X" in the photographs.

14.23 The subpanel can now be laid back toward the input terminal end of the front panel to expose most of the component circuit elements.

15.0 VACUUM-TUBE DATA

The table below lists tube socket voltages measured from socket pin to ground, unless otherwise indicated, using a 20,000 ohm-per-volt meter (Weston 772 Analyzer). D-C voltages may vary $\pm 20\%$.

SYM.	TYPE	SOCKET PIN NUMBER								FUNCTION
		1	2	3	4	5	6	7	8	
V-1	9005	1 and 5 3.2-3.9v AC		-.75v						Diode Rectifier
V-2	Amperite 3-4		2 and 7 5.8v AC							Ballast Tube
V-3	6SL7GT		162	1.35		162	1.35	7 and 8 6.3v AC		D-C Amplifier
V-4	6SL7GT	-212	1.35	-215	-212	1.35	-215	7 and 8 6.3v AC		Degeneration Tube
V-5	9005	1 and 4 3.2-3.9v AC		-.05	-.25					Balancing Diode
V-6	6C4	300		3 and 4 6.3v AC			132	162		Regulator
V-7	6AT6	.25	47	3 and 4 6.3v AC				132		Regulator
V-8	6X5GT/G		2 and 7 6.3v AC	470v AC		470v AC				Rectifier
V-9	991	62v DC across terminals								Neon Regulator
V-10	991	65v DC across terminals								Neon Regulator

CONDITIONS: Input--115v - 60 cycles.
Switch S-1 set to DC, D-C input terminals short-circuited.
VOLTAGE RANGE switch set to 0.5.
B+ set for 450 volts, dc.

ORDER REPLACEMENT PARTS FROM GENERAL RADIO COMPANY

PARTS LIST

Symbol	Rating and Tolerance	Mfr.	Mfr.'s Type No.
RESISTORS			
R-1	100 MΩ +40%, -20%	IRC	BTX-1/2 (Special)
R-2	100 MΩ +40%, -20%	IRC	BTX-1/2 (Special)
R-4	10 MΩ +10%	IRC	BT-1/2
R-5	4700 Ω +10%	IRC	BT-1/2
R-6	4700 Ω +10%	IRC	BT-1/2
R-7	20 Ω +5%	IRC	BW-2
R-8	6 Ω +10%	GR	POSC-862
R-9	20 Ω +5%	IRC	BW-2
R-10	18 MΩ +10%	IRC	BT-1/2
R-11	18 MΩ +10%	IRC	BT-1/2
R-12	1300 Ω +1%	IRC	WW-3
R-13	1 kΩ +10%	GR	POSW-862
R-14	3 kΩ +10%	GR	POSW-862
R-15	11.5 kΩ +1%	IRC	WW-3
R-16	46.1 kΩ +0.25%	IRC	WW-3
R-17	133.4 kΩ +0.25%	IRC	WW-3
R-18	474.4 kΩ +0.25%	IRC	WW-4
R-19	350 kΩ +0.25%	IRC	WW-4
R-20	1 MΩ +0.25%	IRC	WW-5
R-21	1300 Ω +1%	IRC	WW-3
R-22	1 kΩ +10%	GR	POSW-862
R-23	3 kΩ +10%	GR	POSW-862
R-24	8500 Ω +1%	IRC	WW-3
R-25	33.8 kΩ +0.25%	IRC	WW-3
R-26	96.4 kΩ +0.25%	IRC	WW-3
R-27	338.9 kΩ +0.25%	IRC	WW-4
R-28	964 kΩ +0.25%	IRC	WW-5
R-29	0.1 MΩ +10%	IRC	BT-1/2
R-30	0.1 MΩ +10%	IRC	BT-1/2
R-31	100 MΩ +20%	ERIE	504
R-32	100 MΩ +20%	ERIE	504
R-33	47 kΩ +10%	IRC	BT-1/2
R-34	20 kΩ +10%	GR	410-412
R-35	47 kΩ +10%	IRC	BT-1/2
R-36	0.75 MΩ +1%	CCC	X-1/2
R-37	10 kΩ +10%	GR	POSW-862
R-38	1 MΩ +1%	CCC	X-1/2
R-39	0.2 MΩ +1%	CCC	X-1/2
R-40	5.6 MΩ +10%	IRC	BT-1/2
R-41	3.9 MΩ +10%	IRC	BT-1/2
R-42	2.2 kΩ +5%	IRC	BT-1/2
R-43	0.2 MΩ +10%	GR	POSC-860
R-44	0.39 MΩ +10%	IRC	BT-1/2
R-45	0.2 MΩ +10%	GR	POSC-860
R-46	0.22 MΩ +10%	IRC	BT-1/2
R-47	1 MΩ +1%	CCC	X-1/2
R-48	1 MΩ +1%	CCC	X-1/2
R-49	4.7 MΩ +10%	IRC	BT-1/2
R-50	4.7 MΩ +10%	IRC	BT-1/2
R-51	10 MΩ +10%	IRC	BT-1/2
*R-52	10 MΩ +10%	IRC	BT-1/2

*Lab to determine value when adjusting meter.

PARTS LIST (cont)

<u>Symbol</u>	<u>Rating and Tolerance</u>	<u>Mfr.</u>	<u>Mfr.'s Type No.</u>
CONDENSERS			
C-1	0.006 μ f	GR	1800-27
C-2	0.01 μ f	GR	COP-7,2
C-3	0.01 μ f	GR	COP-7,2
C-4	0.5 μ f	GR	COL-13
C-5	4 μ f	GR	COE-19
C-6	4 μ f	GR	COE-19
C-7	0.01 μ f	+10% AEROVOX	1467
C-8	0.01 μ f	+10% AEROVOX	1467
TUBES			
V-1		RCA	9005
V-2		Amperite	3-4
V-3		RCA	6SU7-GTY
V-4		RCA	6SL7-GT
V-5		RCA	9005
V-6		RCA	6C4
V-7		RCA	6AT6
V-8		RCA	6X5-GT/G
V-9		RCA	991
V-10		RCA	991
FUSES			
For 115 v. operation			
F-1	= 0.3 amp. Slow Blow 3AG	GR	FUF-1
F-2	= 0.3 amp. Slow Blow 3AG	GR	FUF-1
For 230 v. operation			
F-1	= 0.15 amp. Slow Blow 3AG	GR	FUF-1
F-2	= 0.15 amp. Slow Blow 3AG	GR	FUF-1
METER			
M-1	100 μ amp. PILOT LAMP	GR	MEDS-26
P-1	6.3-v. 2 Req. (in M-1)		2LAP-939F
SWITCHES			
S-1			SWRW-30
S-2	DPST		Part of S-1
S-3			SWRW-31
PLUG			
PL-1			CDPP-562A
TRANSFORMER			
T-1			345-444-2

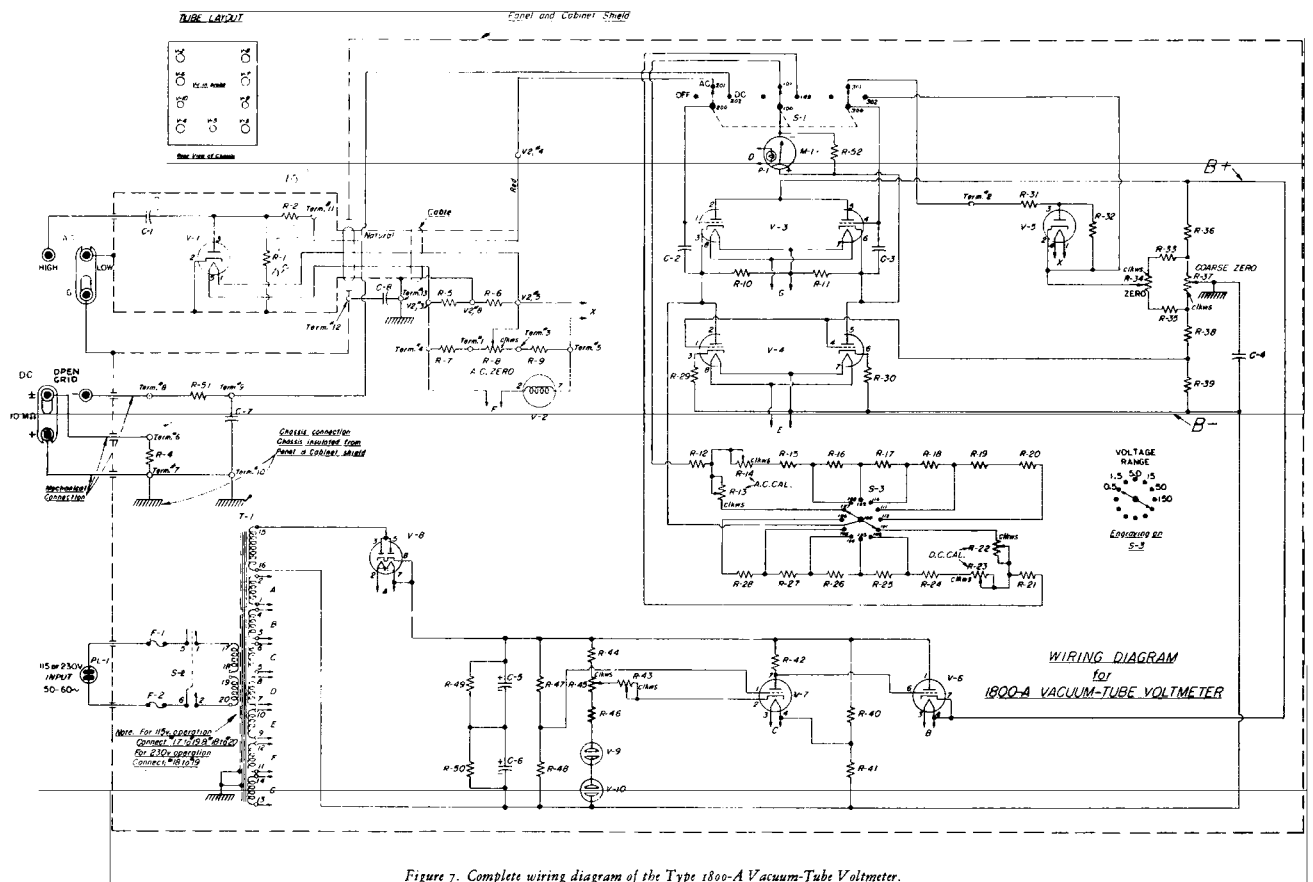

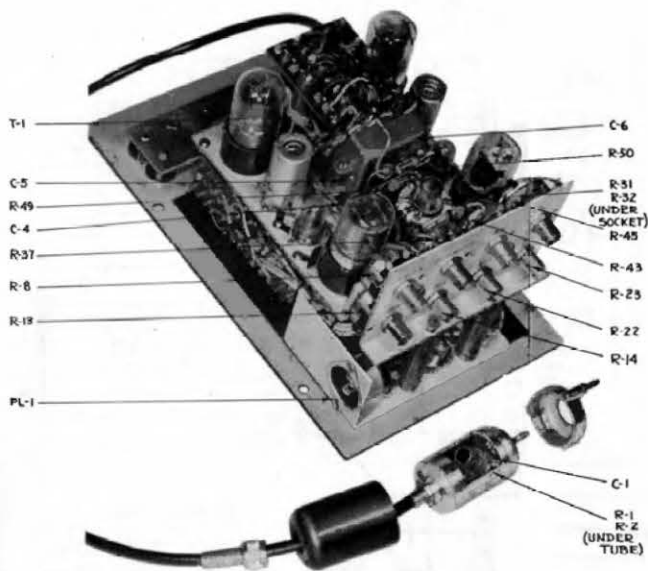

Figure 8. View of interior with cabinet removed.

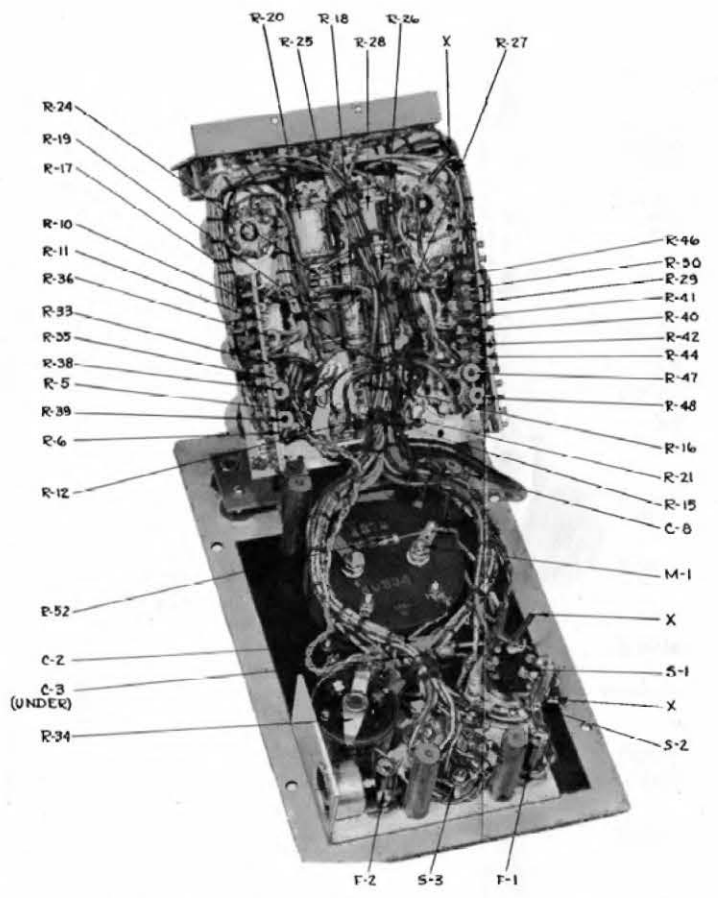

Figure 9. Interior view after subpanel has been laid back (see Section 14.2 of Service and Maintenance Notes).

MULTIPLIERS

Two 10:1 multipliers are available for use with the Type 1800-A Vacuum-Tube Voltmeter: the Type 1800-P2, for use above 30kc, and the Type 1800-P3, for use at dc and at frequencies up to 30 kc. Complete specifications for these multipliers will be furnished on request.