

HK 3480 Stereo Receiver

OWNER'S MANUAL

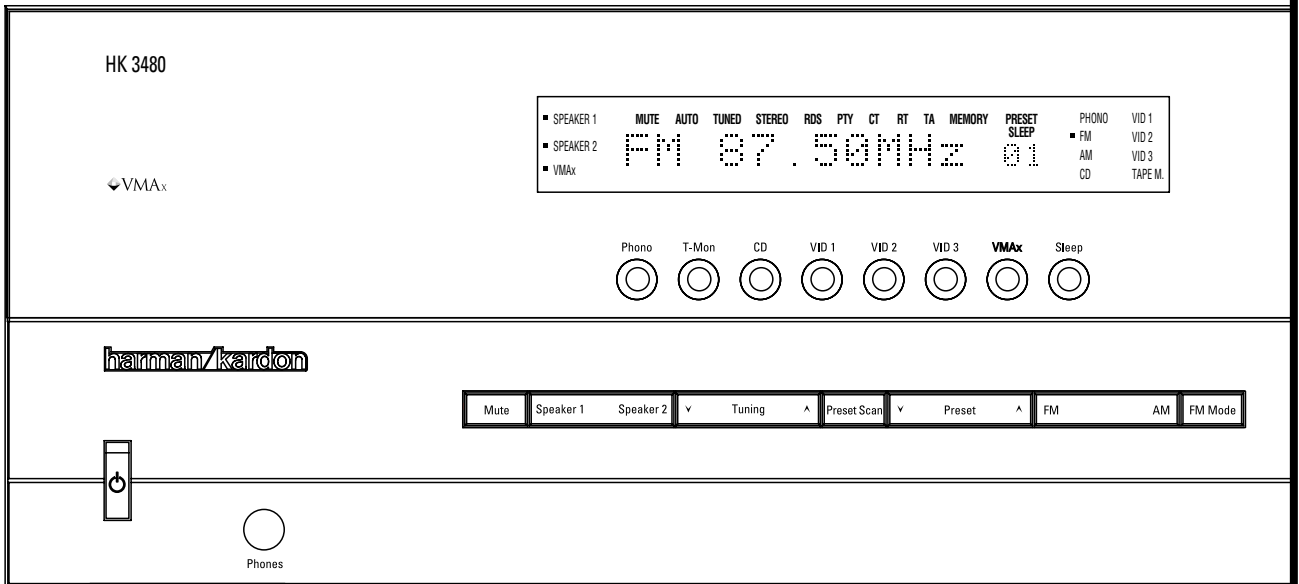

harman/kardon®

Power for the Digital Revolution®

Table of Contents

3	Introduction
3	Important Information
4	Front Panel Controls
6	Rear Panel Connections
8	Remote Control Functions
10	Installation and Connections
12	Operation
12	Basic Operation
12	Source Selection
12	Tuner Operation
13	RDS Operation
14	Tape Recording
14	Memory Backup
14	Processor Reset
15	Using the Remote Control
16	Troubleshooting Guide
17	Technical Specifications

Declaration of Conformity



We, Harman Consumer International
2, Route de Tours
72500 Château-du-Loir,
FRANCE

declare in own responsibility, that the product described
in this owner's manual is in compliance with technical
standards:

EN 55013/6.1990

EN 55020/12.1994

EN 60065:1993

EN 61000-3-2/4.1995

A handwritten signature in black ink, appearing to read 'Carsten Olesen'.

Carsten Olesen
Harman Kardon Europe
10/03

Typographical Conventions

In order to help you use this manual with the remote control, front-panel controls and rear-panel connections, certain conventions have been used.

EXAMPLE – (bold type) indicates a specific remote control or front-panel button, or rear-panel connection jack

EXAMPLE – (OCR type) indicates a message that is visible on the front-panel information display

1 – (number in a square) indicates a specific front panel control

A – (letter in a circle) indicates a button or indicator on the remote

1 – (number in a circle) indicates a rear panel connection

Introduction

Congratulations! With the purchase of the Harman Kardon HK 3480 you are about to begin many years of listening enjoyment.

While sophisticated systems are hard at work within the HK 3480 to make all of this happen, hookup and operation are simple. Color-keyed connections and a comprehensive remote control make the HK 3480 easy to use.

To obtain maximum enjoyment from your new receiver, we urge you to take a few minutes to read through this manual. This will ensure that connections to speakers, source playback units and other external devices are made properly. In addition, a few minutes spent learning the functions of the various controls will enable you to take advantage of all the power the HK 3480 is able to deliver.

If you have any questions about this product, its installation or operation, please contact your dealer. He is your best local source of information.

Description and Features

Harman Kardon's HK 3480 is the world's first stereo receiver to offer VMAx®. VMAx is a proprietary signal-processing technique that creates an open, spacious sound field when only two loudspeakers are available. VMAx circuitry is able to decode the ambience of a concert hall or theater from a stereo recording.

Harman Kardon's HK 3480 is a full-featured Stereo receiver, with five inputs and an FM stereo/FM/AM tuner with RDS capabilities that provide for the utmost flexibility. A high-quality phono input is available so that you may continue to enjoy your existing record collection as well as the latest CD recordings.

The HK 3480's powerful amplifier uses traditional Harman Kardon High-Current Design philosophies to meet the wide dynamic range of any program selection.

Harman Kardon invented the high-fidelity receiver more than fifty years ago. With state-of-the-art features and time-honored circuit designs, the HK 3480 is one of the finest receivers ever offered by Harman Kardon.

- **Harman Kardon Designed High-Current, Ultrawide Bandwidth Amplifier**
- **VMAx Processing Mode - Exclusive to Harman Kardon Receivers**
- **Four video inputs and a recording output**
- **Front-panel audio/video inputs**
- **Phono Input Section**
- **Speaker 1/Speaker 2 Outputs for High-Quality Sound in Two Locations**
- **Pre-Out/Main-In jacks for use with External Amplifiers, Equalizers or Speaker Processors**
- **System Remote Control with Numeric Keys**
- **Subwoofer Output**
- **Tuner with RDS Data Program Information Displays**

Important Information

Verify Line Voltage Before Use

Your HK 3480 has been designed for use with 220-240-volt AC current. Connection to a line voltage other than that for which it is intended can create a safety and fire hazard, and may damage the unit.

If you have any questions about the voltage requirements for your specific model, or about the line voltage in your area, contact your selling dealer before plugging the unit into a wall outlet.

Do Not Open the Cabinet

There are no user-serviceable components inside this product. Opening the cabinet may present a shock hazard, and any modification to the product will void your guarantee. If water or any metal object such as a paper clip, wire or staple accidentally falls inside the unit, disconnect it from the AC power source immediately, and consult an authorized service station.

Installation Location

- To assure proper operation, and to avoid the potential for safety hazards, place the unit on a firm and level surface, that can support the weight of the product.
- Make certain that proper space is provided both above and below the unit for ventilation. If this product will be installed in a cabinet or other enclosed area, make certain that there is sufficient air movement within the cabinet. Under some circumstances a fan may be required.
- Do not place the unit directly on a carpeted surface.
- Avoid installation in extremely hot or cold locations, or an area that is exposed to direct sunlight or heating equipment.
- Avoid moist or humid locations.
- Do not obstruct the ventilation slots on the top of the unit, or place objects directly over them.

Cleaning

When the unit gets dirty, wipe it with a clean, soft, dry cloth. If necessary, wipe it with a soft cloth dampened with mild soapy water, then a fresh cloth with clean water. Wipe dry immediately with a dry cloth. NEVER use benzene, aerosol cleaners, thinner, alcohol or any other volatile cleaning agent. Do not use abrasive cleaners, as they may damage the finish of metal parts. Avoid spraying insecticide near the unit.





Moving the Unit

Before moving the unit, be certain to disconnect any interconnection cords with other components, and make certain that you disconnect the unit from the AC outlet.

Unpacking

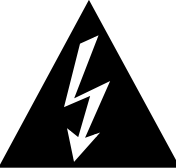
The carton and shipping materials used to protect your new receiver during shipment were specially designed to cushion it from shock and vibration. We suggest that you save the carton and packing materials for use in shipping if you move, or should the unit ever need repair.

If you do not wish to save the packaging materials, please note that the carton and other sections of the shipping protection are recyclable. Please respect the environment and discard those materials at a local recycling center.

	CAUTION RISK OF ELECTRIC SHOCK DO NOT OPEN	
CAUTION: TO REDUCE THE RISK OF ELECTRIC SHOCK, DO NOT REMOVE COVER (OR BACK). NO USER-SERVICEABLE PARTS INSIDE. REFER SERVICING TO QUALIFIED SERVICE PERSONNEL.		
	The lightning flash with arrowhead symbol, within an equilateral triangle, is intended to alert the user to the presence of uninsulated "dangerous voltage" within the product's enclosure that may be of sufficient magnitude to constitute a risk of electric shock to persons.	
The exclamation point within an equilateral triangle is intended to alert the user to the presence of important operating and maintenance (servicing) instructions in the literature accompanying the appliance.		
WARNING: TO REDUCE THE RISK OF FIRE OR ELECTRIC SHOCK, DO NOT EXPOSE THIS APPLIANCE TO RAIN OR MOISTURE.		

Front Panel Controls

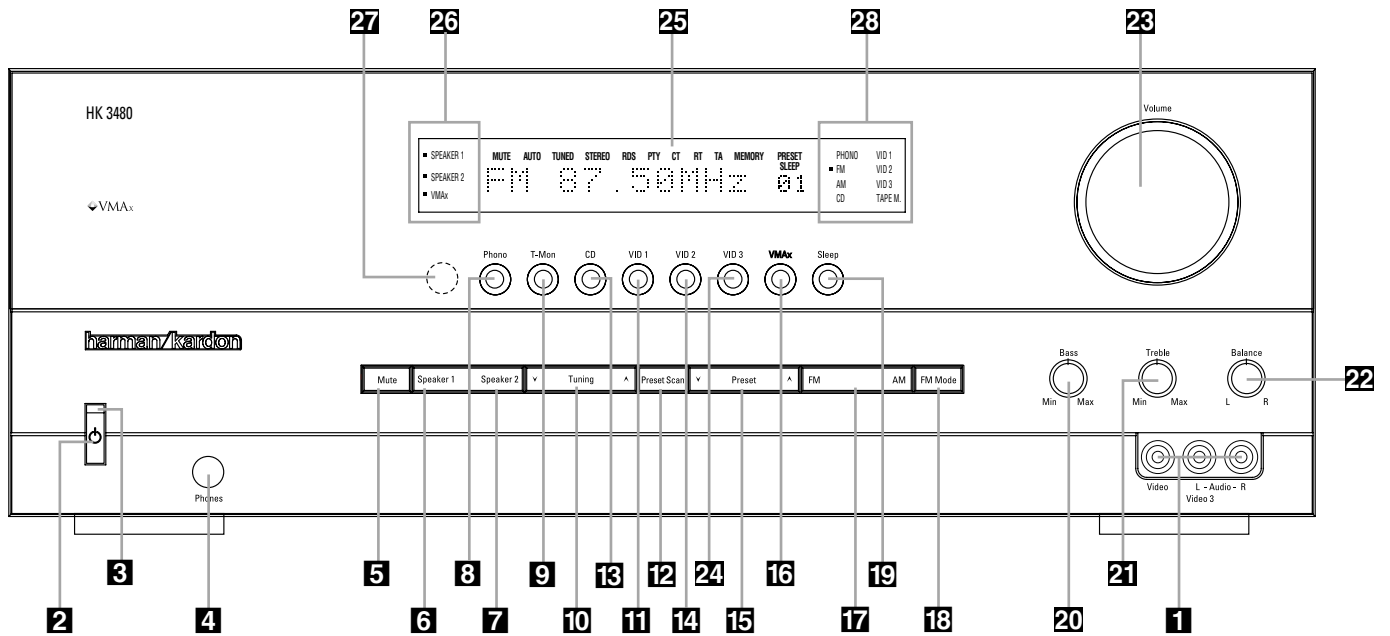

- 1** Video 3 input jacks
- 2** System Power Control
- 3** Power Indicator
- 4** Headphone Jack
- 5** Mute
- 6** Speaker 1 Selector
- 7** Speaker 2 Selector
- 8** Phone Input Selector
- 9** T-Mon Input Selector
- 10** Tuning Button

- 11** Video 1 Input Selector
- 12** Preset Scan
- 13** CD Input Selector
- 14** Video 2 Input Selector
- 15** Preset Selector
- 16** VMAx Selector
- 17** FM/AM Selector
- 18** FM Mode Selector
- 19** Sleep Button
- 20** Bass Control

- 21** Treble Control
- 22** Balance Control
- 23** Volume Control
- 24** Video 3 Input Selector
- 25** Information Display
- 26** Speaker Selection Indicators
- 27** Remote Sensor Window
- 28** Input Indicators

1 Video 3 Input Jacks: These audio/video jacks may be used for temporary connection to video games or portable audio/video products such as camcorders and portable audio players.

To select the front-panel inputs, press the **Video 3 Input Selector 24** repeatedly until the dot to the left of the **Video 3 Input Indicator 23** flashes. In order to view the video signal of a video device connected to this input, remember to connect the **Video Monitor Output 21** to the video input of your TV or video display.

2 System Power Control: When the **Main Power Switch 1** is "ON," press this button to turn on the HK 3480; press it again to turn the unit off (to Standby). Note that the **Power Indicator** surrounding the switch **3** will turn blue when the unit is on.

3 Power Indicator: This LED will illuminate in amber when the unit is in the Standby mode to signal that the unit is ready to be turned on. When the unit is in operation, the indicator will turn blue. A red indicator means that the unit is in the Protect mode, and should be turned off and then checked for a possible speaker wire short circuit.

4 Headphone Jack: This jack may be used to listen to the HK 3480's output through a pair of headphones. Be certain that the headphones have a standard 6,3 mm stereo phone plug.

5 Mute: Press this button to momentarily silence the speaker and preamp output of the HK 3480.

6 Speakers 1 Selector: Press this button to turn the speakers connected to the **Speaker 1** output terminals **17** on or off.

7 Speakers 2 Selector: Press this button to turn the speakers connected to the **Speaker 2** output terminals **18** on or off.

Front Panel Controls

8 Phono Input Selector: Press this button to select the output of a turntable that is connected to the **Phono** inputs **6**.

9 T-Mon Input Selector: Press this button to listen to the output of a tape recorder connected to the **Tape Monitor** inputs **9**. The **TAPE M.** will be highlighted in the **Input Indicators 23** to indicate that the input source is being monitored when the HK 3480 is connected to a three-head tape deck or another unit with off-head playback.

10 Tuning Button: Press the left side of the button to tune lower frequency stations and the right side of the button to tune higher frequency stations. When a station with a strong signal is tuned, the **TUNED** indicator will illuminate in the **Information Display 25**. A brief press of the button will manually tune to the next frequency increment, while pressing and holding the button for a longer period (>0.5 sec) will step quickly through the frequencies. As soon as the button is released the unit will automatically tune to the next station with a signal strong enough for acceptable reception.

11 Video 1 Input Selector: Press this button to listen to and/or view the output of a device connected to the **Video 1 Inputs 8**.

12 Preset Scan: Press this button to automatically scan through the stations that have been programmed in the HK 3480's memory. The tuner will play five seconds of each station before moving to the next preset station. To stop the scan when the desired station is heard, press the button again. (See page 13 for more information on the tuner memory system.)

13 CD Input Selector: Press this button to listen to the output of a CD player connected to the **CD** inputs **7**.

14 Video 2 Input Selector: Press this button to listen to and/or view the output of a device connected to the **Video 2 Inputs 12**.

15 Preset Selector: Press this button to step up or down through the list of stations that has been entered into the preset memory. (See page 13 for more information on tuner programming.)

16 VMaX Selector: Press this button to engage VMaX processing of a stereo input. The **VMaX indicator 26** will light, and you will notice a wider, more spacious field. In order to obtain maximum benefit, you should be seated midway between the two loudspeakers, and the same distance from the speakers as the speakers are from each other. The speakers must be placed facing parallel and evenly with each other so that their baffles are in the same plane. Press the button again to return to Stereo mode.

17 FM/AM Selector: Press this button to select the tuner as the input to the receiver. When the tuner is in use, press this button to change between the AM and FM frequency bands.

Note: When an RDS station is tuned, the FM button has the same function as the RDS Display button on the remote control. Press to cycle through the various RDS displays (see page 13).

18 FM Mode Selector: Press this button to select the stereo or mono mode for FM tuning. In the STEREO mode, a **Stereo Indicator** will illuminate in the **Information Display 25**, and stereo reception will be provided when stations are transmitting stereo signals. In the MONO mode, the left and right signals from stereo broadcasts will be mixed together and reproduced through all channels. Select MONO for better reception of weak signals.

19 Sleep Button: Press this button to place the unit in the Sleep mode. Each press of the button selects the amount of time that will remain before the unit automatically goes into the Standby mode, as shown in the **Information Display 25**, in the following order:

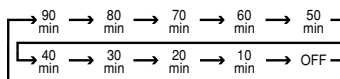

20 Bass Control: Turn this control to modify the low-frequency output of the left/right channels by as much as ± 10 dB. Set this control to a suitable position for your taste and room acoustics.

21 Treble Control: Turn this control to modify the high-frequency output of the left/right channels by as much as ± 10 dB. Set this control to a suitable position for your taste and room acoustics.

22 Balance Control: Turn this control to change the relative volume for the front left/right channels.

23 Volume Control: Turn the knob clockwise to increase volume, counterclockwise to decrease the volume.

24 Video 3 Input Selector: Press this button to listen to and/or view the output of a device connected to the **Video 3 Inputs 14 1** on either the front or rear panel. If devices are connected to both the front- and rear-panel **Video 3 Inputs 14 1**, then the device connected to the rear-panel **Video 3 Inputs 14** will be selected first, as indicated by the dot to the left of the **Video 3 Input Indicator 23** being steadily lit. To select the device connected to the front-panel **Video 3 Inputs 1**, press the **Video 3 Input Selector 24** again so that the dot to the left of the **Video 3 Input Indicator 23** flashes. Each subsequent press of the **Video 3 Input Selector 24** will toggle between the front and rear **Video 3 Inputs 14 1**.

25 Information Display: This display delivers messages and status indications to help you operate the receiver.

26 Speaker Selection Indicators: These indicators light as a green LED next to the designation for each speaker pair to show when they are active. Press the **Speaker 1 6** or **Speaker 2 7** Selectors to activate either pair of speakers. Both sets of speakers may be selected simultaneously as long as all speakers are nominally rated at an impedance of 8 ohms or greater. However, occasionally the actual impedance will vary, depending upon the program material. When the impedance drops too low, the HK 3480 will go into protect mode in order to prevent damage to the equipment. If this should occur frequently, be sure to select only one set of speakers at a time until you are able to obtain speakers with a higher nominal impedance.

27 Remote Sensor Window: The sensor behind this window receives infrared signals from the remote control. Aim the remote at this area and do not block or cover it unless an external remote sensor is installed.

28 Input indicators: A blue LED will light in front of the input that is currently being used as the source for the AVR.

Rear Panel Connections

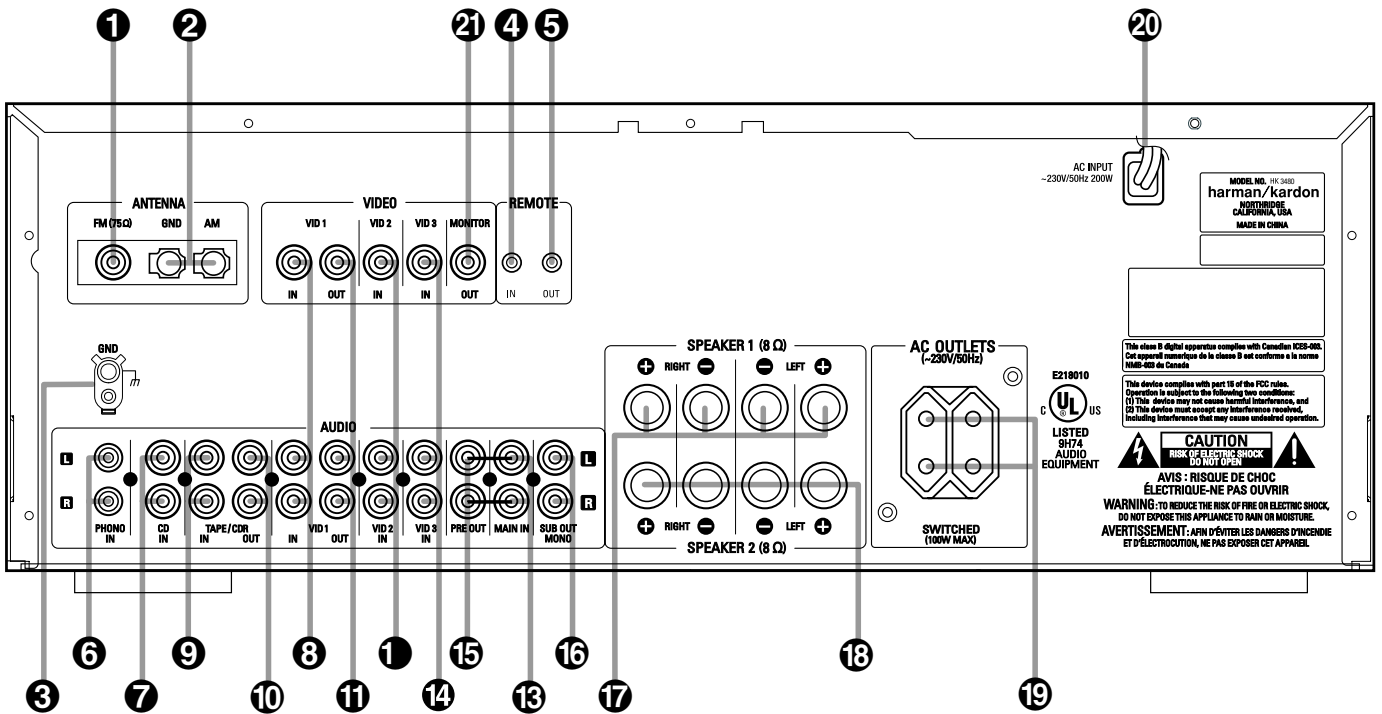

- | | | |
|---|--|---|
| <ul style="list-style-type: none"> 1 AM Antenna 2 FM Antenna 3 Phono Ground 4 Remote IR In 5 Remote IR Out 6 Phono Inputs 7 CD Inputs 8 Video 1 Audio/Video Play/In | <ul style="list-style-type: none"> 9 Tape Monitor Play/In 10 Tape Monitor Record/Out 11 Video 1 Audio/Video Record/Out 12 Video 2 Audio/Video Inputs 13 Main In 14 Video 3 Audio/Video Inputs 15 Preamp Out 16 Subwoofer Out | <ul style="list-style-type: none"> 17 Speaker 1 Terminals 18 Speaker 2 Terminals 19 Switched AC Outlet 20 Power Cable 21 Video Monitor Outputs |
|---|--|---|

Rear Panel Connections

1 AM Antenna: Connect the AM loop antenna supplied with the receiver to these terminals. If an external AM antenna is used, make connections to the **AM** and **GND** terminals in accordance with the instructions supplied with the antenna.

2 FM Antenna: Connect an indoor or external FM antenna to this terminal.

3 Phono Ground: Connect the ground wire from a turntable to this terminal to reduce system hum.

4 Remote IR In: If the HK 3480's front panel IR sensor is blocked due to cabinet doors or other obstructions, an external IR sensor may be used. Connect the output of the sensor to this jack.

5 Remote IR Out: This connection permits the IR sensor in the receiver to serve other remote controlled devices. Connect this jack to the "IR IN" jack on Harman Kardon or other compatible equipment.

6 Phono Inputs: Connect the outputs of your turntable or tone arm to these jacks. Note that only Moving Magnet (MM) type cartridges may be used.

7 CD Inputs: Connect these jacks to the output of a compact disc player or CD changer.

8 Video 1 Audio/Video Play/In: Connect these jacks to the PLAY/OUT jacks of an audio or video device, such as a VCR or DVD player. In order to view the video signal of a video device connected to this input, remember to connect the **Video Monitor Output 21** to the video input of your TV or video display.

9 Tape Monitor Play/In: Connect these jacks to the Play/Out jacks of an audio recorder.

10 Tape Monitor Record/Out: Connect these jacks to the Rec/In jacks of an audio recorder.

NOTE: When these jacks are connected to a three-head recorder or another device with off-head playback, it will be possible to monitor the source being recorded.

11 Video 1 Audio/Video Record/Out: Connect these jacks to the Rec/In jacks of an audio or video recorder.

12 Video 2 Audio/Video Inputs: Connect these jacks to the PLAY/OUT jacks of an audio or video device, such as a VCR or DVD player. In order to view the video signal of a video device connected to this input, remember to connect the **Video Monitor Output 21** to the video input of your TV or video display.

13 Main In: These jacks are the input to the HK 3480's power amplifier. Unless an external power amplifier is used, the jumper pins should remain connected to the **Preamp Out** jacks 15.

14 Video 3 Audio/Video Inputs: Connect these jacks to the PLAY/OUT jacks of an audio or video device, such as a VCR or DVD player. In order to view the video signal of a video device connected to this input, remember to connect the **Video Monitor Output 21** to the video input of your TV or video display.

15 Preamp Out: These jacks provide an output for the left and right channels to an optional external amplifier. In normal operation, unless an external power amplifier is used, the jumper pins should remain connected to the **Main In** jacks 13.

16 Subwoofer Out: Connect these jacks to the line-level input of a powered subwoofer. If an external subwoofer amplifier is used, connect this jack to the subwoofer amplifier input. When a single, mono subwoofer is used, make the connection to the bottom jack.

17 Speaker 1 Terminals: Connect these terminals to the appropriate terminals on your speakers.

18 Speaker 2 Terminals: Connect these terminals to the appropriate terminals on your speakers.

NOTE: The power consumption of the devices plugged into these outlets should not exceed 100 watts.

19 Switched AC Outlet: These outlets may be used to power low-current draw devices such as CD players or cassette decks. The power to these outlets remains on as long as the receiver itself is on. When the receiver is turned off, or placed in the Standby mode, power to these outlets is removed.

20 Power Cable: Connect the AC plug to a nonswitched AC wall output.

21 Video Monitor Output: Connect this jack to the composite video input of your TV or video display device. Doing so will enable you to view the video signal of a properly connected video source device, when that source input is selected. When an audio-only source is selected, the **Video Monitor Output 21** will not transmit a video signal.

Remote Control Functions

- A** Main Power On
- B** Main Power Off
- C** Source Selectors
- D** Preset Up/Down
- E** Transport Controls
- F** Disc Skip
- G** Sleep Button
- H** Dimmer Button
- I** Main Tuning Buttons
- J** Direct Button
- K** Numeric Keys
- L** Auto Preset
- M** Secondary Control Cover
- N** Clear Button
- O** Memory Button
- P** Master Volume
- Q** P. Scan Button
- R** Mute Button
- S** FM Mode Button
- T** Tuning Up/Down
- U** Speaker 1 Selector
- V** Speaker 2 Selector
- W** Transmitter Window
- X** Enter Button
- Y** RDS Display Button
- Z** RDS PTY Button
- AA** VMaX

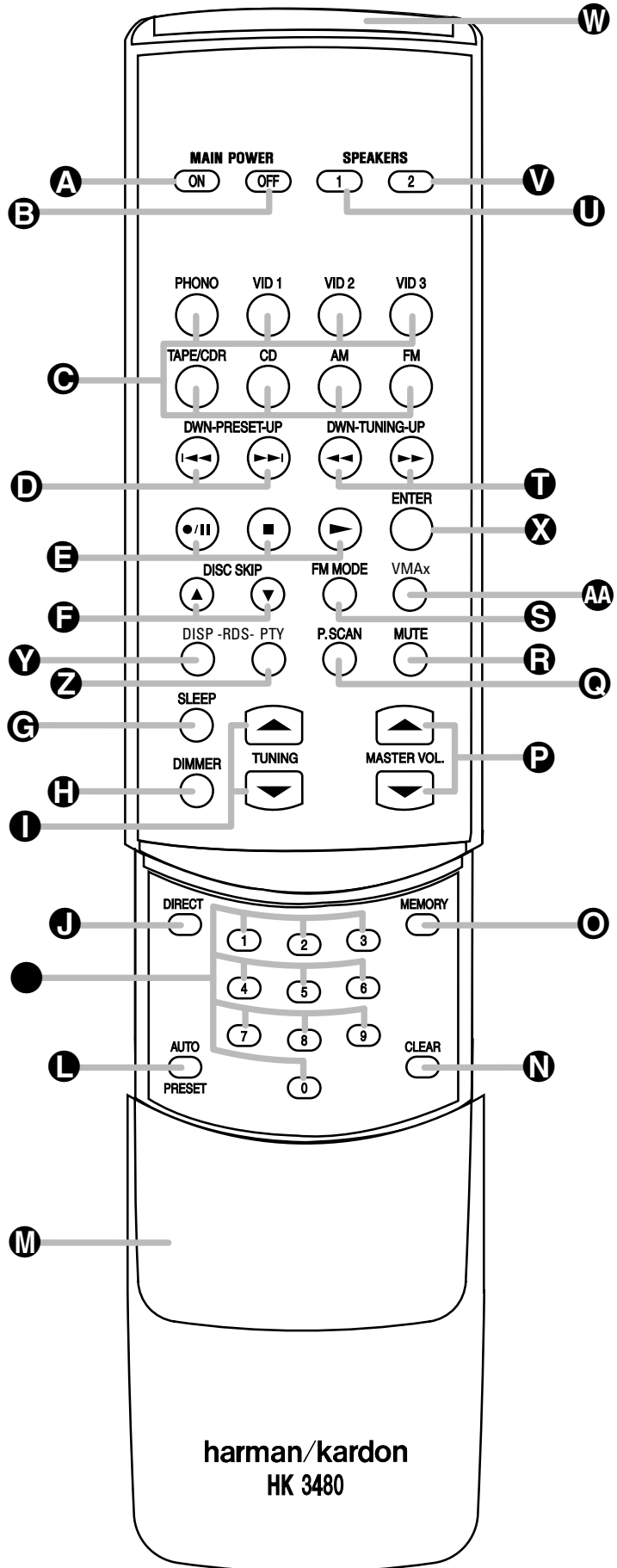

Remote Control Functions

The remote is capable of operating the HK 3480 and most Harman Kardon CD changers or players, CD Recorders and Tape decks, using the control codes that are part of the remote.

A Main Power On: When the HK 3480 is in the Standby mode, as indicated by the **Power Indicator** **3** glowing amber, press this button to turn the HK 3480 on.

B Main Power Off: When the HK 3480 is turned on, press this button to place it in the Standby mode. Note that in this condition, the unit is still connected to AC Power.

C Source Selectors: Press these buttons to select an input source for the HK 3480.

NOTE: The first press of the **Video 3 Source Selector** **6** will select the device connected to the rear-panel **Video 3 Audio/Video Inputs** **14**. Press the **Video 3 Source Selector** **6** again until the dot to the left of the **Video 3 Input Indicator** **23** flashes to select the device connected to the front-panel **Video 3 Audio/Video Inputs** **1**. Each additional press of the **Video 3 Source Selector** **6** will toggle between the front- and rear-panel **Video 3 Audio/Video Inputs** **14** **1**.

D Preset Up/Down: When the tuner is in use, these buttons scroll through the stations that have been programmed into the HK 3480's memory. These buttons also control the track Skip Up and Down on compatible Harman Kardon compact disc players/changers, CD-Recorders and cassette decks (with that function).

E Transport Controls: These buttons are used to control Play, Play Forward, Play Reverse, Stop, Pause and Record functions on compatible Harman Kardon compact disc players/changers and cassette tape decks. Also, when a compatible Harman Kardon compact disc player or changer, or cassette deck, has been selected using the **Source Selectors** **6**, additional transport control functions are available using the **Preset Up/Down** **D** and **Tuning Up/Down** **I** buttons.

F Disc Skip: These buttons do not have any functions when controlling the HK 3480, but they operate the Disc Skip functions of compatible Harman Kardon compact disc changers.

G Sleep Button: Press this button to place the unit in the Sleep mode. Each press of the button selects the amount of time that will remain before the unit will automatically go into the Standby mode, as shown in the **Main Information Display** **25**, in the following order:

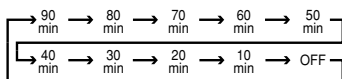

Holding the button pressed for some seconds will directly turn off the Sleep time selection.

H Dimmer Button: Press this button once to reduce the brightness of the front panel display to

half the normal intensity. Press it again to turn the front panel display completely off. When the display is completely off, press the button to return to normal brightness.

I Main Tuning Buttons: When the tuner is in use, these buttons will tune up or down through the selected frequency band. A brief press of the button will manually tune to the next frequency increment, while pressing and holding the button for a longer period (>0.5 sec) will step quickly through the frequencies. As soon as the button is released the unit will automatically tune to the next station with a signal strong enough for acceptable reception. When a HK CD Recorder is in use these buttons will select the transport (Play or Record Deck).

J Direct Button: Press this button to select a radio station by entering its frequency using the **Numeric Keys**. (See page 12 for more information.)

K Numeric Keys: These buttons serve as a ten-button numeric keypad to enter tuner preset positions or track numbers with CD players/changers or to tune stations directly.

L Auto Preset: When the tuner and FM band have been selected, this button may be used to automatically program the tuner presets for all stations with acceptable signal strength. To start the auto preset scan, press and hold the button. Note that the **MEMORY** and **PRESET** indicators will flash. Keep holding the button pressed until the tuner will start to "look" for stations, as shown by increasing frequency numbers in the Information Display. Release the button and note that the tuner will search the entire FM band and stop briefly at each station that has acceptable signal strength. The HK 3480 will automatically assign a preset number to each station and then search for the next station. If the FM tuner finds fewer than 30 FM stations with acceptable signal strength, the Auto Preset tuning will scan two more cycles or until the remaining vacant preset memory spaces have been filled with those found in the first scan. The scan will stop when all 30 preset memory spaces have been filled or when three scans through the band have been completed (see page 13 for more information).

M Secondary Control Cover: This sliding cover normally hides the secondary controls. To access these controls, gently press the cover down and towards you.

N Clear Button: This button is used to clear preset memory information for the HK 3480's tuner. (See page 13 for more information on tuner presets.)

O Memory Button: Press this button to open a memory position that stores a preset location for the HK 3480's tuner. (See page 13 for more information on tuner presets.)

P Master Volume: Press these buttons to raise or lower the HK 3480's volume.

Q P. Scan Button: Press this button to automatically scan through the list of stations that are programmed into the HK 3480's tuner memory. When the button is pressed, each preset station will play for five seconds before the next station is selected. Press the button again when the desired station is heard to stop the preset scan.

R Mute Button: Press this button to momentarily silence the HK 3480.

S FM Mode Button: Press this button when the tuner is in use in the FM band to switch to monaural reception if the stereo station is weak and noisy. (See page 12 for more information.)

T Tuning Up/Down: When the tuner is in use, these buttons work in the same way as the **Main Tuning** buttons **I** described above. But if CD or Tape is in use, these buttons will also control Fast Forward and Fast Reverse (or Rewind) for compatible Harman Kardon compact disc players/changers, CD-Recorders and cassette tape decks.

U Speaker 1 Selector: Press this button to turn the speakers connected to the **Speaker 1 Output** terminals **17** on or off.

V Speaker 2 Selector: Press this button to turn the speakers connected to the **Speaker 2 Output** terminals **18** on or off.

W Transmitter Window: Point this area of the remote toward the receiver when using the remote.

X Enter Button: This button has no function on the HK 3480, but may be used as the Enter key for a compatible Harman Kardon DVD Player or as the Random Play button for a compatible CD Player. (See page 16 for more information on using the remote to control other devices.)

Y RDS Display Button: Press this button to view the various displays of the RDS options that are available when a station is transmitting RDS data. (See pages 13-14 for more information on RDS tuning.)

Z RDS PTY Button: Press this button to start a search for a specific PTY type using the RDS capabilities of the HK 3480. (See pages 13-14 for more information on RDS tuning.)

AA VMaX Selector: Press this button to engage VMaX processing of a stereo input. The **VMaX Mode Indicator** **26** will light, and you will notice a wider, more spacious sound field. In order to obtain maximum benefit, you should be seated midway between the two loudspeakers, and the same distance from the speakers as the speakers are from each other. The speakers must be placed facing parallel and evenly with each other so that their baffles are in the same plane. Press the button again to return to Stereo mode.

Installation and Connections

Audio and Speaker Connections

After unpacking the unit and placing it on a solid surface capable of supporting its weight, you will need to make the connections to your audio and video equipment. These steps need to be done only when the receiver is first installed or when a change is made to the input source equipment.

Audio Equipment Connections

We recommend that you use high-quality interconnect cables when making connections to source equipment and recorders to preserve the quality of the signals.

When making connections to audio source equipment or speakers it is always a good practice to unplug the unit from the AC wall outlet. This prevents any possibility of accidentally sending audio or transient signals to the speakers that may damage them.

1. Connect the analog output of a CD player to the **CD** inputs **7**.

NOTE: When the CD player has both fixed and variable audio outputs, it is best to use the fixed output unless you find that the input to the receiver is so low that the sound is noisy, or so high that the signal is distorted.

2. Connect the Play/Out jacks of a cassette deck, CDR, MD or other audio recorder to the **Tape Monitor Play** jacks **9**. Connect the Record/In jacks on the recorder to the **Tape Monitor Rec. Out** jacks **10** on the HK 3480. When the tape deck connected to these jacks is a three-head unit or has off-head playback, it will be possible to monitor the output of the source being recorded.

3. Connect the audio and/or video outputs of a second audio recorder, VCR or other line-level audio device to the **Video 1 Audio/Video Input Jacks 8**. If a recorder is used, connect its Rec/In jacks to the matching outputs **11**.

4. The audio output of any electronics product with a line-level output, such as a TV set, satellite receiver or DVD, may be connected to the **Aux** jacks **8**. **Video 2** and **Video 3** **Audio/Video inputs 12/14**.

NOTE: In order to view the video signals of any devices connected to the **Video 1 8**, **Video 2 12** or **Video 3 14** **Video Inputs**, you will need to connect the **Video Monitor Output 21** jack to the composite video input of your TV or other video display device.

5. Connect the outputs of a turntable with a moving magnet cartridge to the **Phono** inputs **6**. To insure that the phono playback is noise-free, connect the ground wire from the tone-arm to the **Phono Ground** terminal **3**.

6. Assemble the AM Loop Antenna supplied with the unit as shown below. Connect it to the **AM** screw terminals **1**.

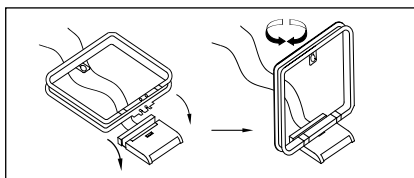

7. Connect an FM antenna to the **FM Antenna** connection **2**. The FM antenna may be an external roof antenna, an inside powered or wire lead antenna or a connection from a cable system. Note that if the antenna or connection uses 300-ohm twin-lead cable, you must use the 300-ohm-to-75-ohm adapter supplied with the unit to make the connection.

8. If you wish to use external processing equipment, such as an equalizer, you may connect the device to the preamp-out and main-in jacks by removing the **Preamp-Out/Main-In Jumper Pins 13** and connecting the **Preamp Out 15** jacks to the inputs of the external device, and the outputs of the device to the **Main In 18** jacks.

Alternatively, you may connect the external device to the Tape Monitor Loop. Connect the **Tape Monitor Record/Out** jacks **10** to the inputs of the external device, and connect the outputs of the device to the **Tape Monitor Play/In** jacks **9**.

Speaker and Output Connections

Regardless of the brand of cable selected, we recommend that you use a cable constructed of fine, multistrand copper with an area of min. 2 mm².

Cable with 1.5 mm² may be used for short runs of less than 3 meters. We do not recommend that you use cables with an area of 0.8 mm² or smaller due to the power loss and degradation in performance that will occur.

Questions about running cables inside walls should be referred to an installer or a licensed electrical contractor who is familiar with applicable local building codes in your area.

When connecting wires to the speakers, be certain to observe proper polarity. Remember to connect the "negative" or "black" wire to the same terminal on the receiver and the speaker. Similarly, the "positive" or "red" wire should be connected to the like terminals on the HK 3480 and speaker.

We also recommend that the length of cable used to connect speaker pairs be identical. For example, use the same length piece of cable to connect the Speaker 1 left and right or Speaker 2 left and right speakers, even if the speakers are a different distance from the HK 3480.

NOTE: While most speaker manufacturers adhere to an industry convention of using black terminals for negative and red ones for positive, some manufacturers may vary from this configuration. To assure proper phase, and optimal performance, consult the identification plate on your speaker, or the speaker's manual to verify polarity.

If you do not know the polarity of your speaker, assure that both speakers are connected with the same polarity, i.e. speaker wires or terminals with any marking should be connected to the red speaker terminals on the HK 3480, the others to the black ones (see connections below).

Connect the speakers using the following steps:

1. Connect the main speakers to the **Speaker 1** terminals **17**.

2. Connect a second set of speakers, or speakers that are in a second room location, to the **Speaker 2** terminals **18**.

3. When an optional, powered subwoofer (not the active Sub of a Sub/Sat-System) is used, connect the outputs of the left and right **Subwoofer Out** jacks **16** to the line-level inputs of the subwoofer. When the subwoofer's amplifier has stereo inputs, run interconnects from both jacks. When the subwoofer has a mono input only, use the bottom output jack for the connection. When a separate passive subwoofer is used, these connections will be made to the optional amplifier that powers the subwoofer. If a Sub/Sat system is used (active or passive), connect the **Speaker 1** terminals **17** to the speaker-level inputs on the subwoofer, and then connect the speaker-level outputs on the subwoofer to your main left and right speakers, following the instructions provided with the subwoofer.

Installation and Connections

System and Power Connections

The HK 3480 is designed for flexible use with external control components and power amplifiers. These connections are easy to make during an initial installation, or at a later date should you choose to upgrade your system.

Remote Control Extension

If the receiver is placed behind a solid or smoked glass cabinet door, the obstruction may prevent the remote sensor from receiving commands. In this event, an optional remote sensor may be used. Connect the output of the remote sensor to the **Remote IR In** jack ④.

If other components are also prevented from receiving remote commands, only one sensor is needed. They may use this unit's sensor or a remote eye by running a connection from the **Remote IR Out** jack ⑤ to the Remote In jack on Harman Kardon or other compatible equipment.

External Audio Power Amplifier Connections

If desired, an optional, external amplifier may be used in place of the HK 3480's internal power amplifier.

To connect an external power amplifier, first remove the **Pre-Out/Main-In Jumper Pins** ⑭ that connect the **Preamp Out** ⑮ and **Main In** ⑯ jacks on the rear panel. Keep the jumpers in a safe place should they be needed at a later time.

Using high-quality audio interconnect cables, connect the **Preamp Out** jacks ⑮ to the input jacks on your power amplifier. Make certain to match the right output to the right input and the left output to the left input.

Note that when an external power amplifier is used, no special adjustments are required. All volume and other control adjustments are made using the standard front panel or remote controls.

AC Power Connections

This unit is equipped with an accessory AC outlet. It may be used to power accessory devices, but it should not be used with high-current draw equipment such as power amplifiers. The total power draw may not exceed 100W at this outlet.

This **Switched AC Outlet** ⑰ will receive power only when the unit is on. This is recommended for devices that have no power switch, or those with a mechanical power switch that may be left in the "ON" position.

NOTE: Devices with electronic power switches may only go into a Standby mode when plugged in here.

Speaker Placement

For optimal listening enjoyment, and for sound-field reproduction that best re-creates the original recording, it is good practice to place the speakers so that they form a triangle with the speakers at the front of the room, and the preferred listening spot at the third point of the triangle. The distance between each speaker and the listener should be identical.

For example, if the speakers are 2,5 meters from one another, each of the speakers should optimally be placed so that they are also 2,5 meters from the listener. It is also desirable to place speakers so that their tweeters, or highfrequency drivers, are aimed at ear height when you are seated in the listening position.

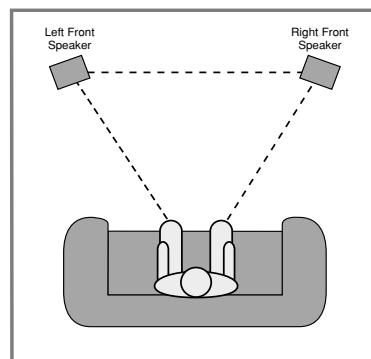

A good starting point for speaker placement is to make the distance between the two speakers and the distance between either speaker and the listener identical.

To optimize the sound field, or to suit your listening room environment, you may find that some experimentation is required to find the correct location. Ideally, pans from left to right across the front of the room should sound smooth, and instruments should appear to be coming from the proper location within an orchestra.

The placement of subwoofers should be done as suggested in the manufacturer's instructions. In general, subwoofers often produce best results when they are placed in the corner of a room, along the same wall as the speakers, but optimal placement will vary widely depending on room size, the subwoofer type and the placement of rugs and furniture in a room. It may be helpful to temporarily position the subwoofer in the usual listening position, then walk around the room while program material is playing until the bass reproduction sounds best to your ears. That location is likely to be the optimum position for the subwoofer.

Finally, when all connections are complete, plug the power cord into a nonswitched 230-volt AC wall outlet. You're ready to enjoy the HK 3480!

Operation

Basic Operation

The HK 3480 is simple to operate, and very similar to stereo receivers you may have used in the past. This section will explain the use of several features that may be new to you.

- Install the two supplied AAA batteries in the remote as shown. Be certain to observe the (+) and (-) polarity indicators shown in the bottom of the battery compartment.

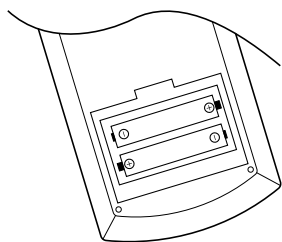

- When using the HK 3480 for the first time, the unit will be in a standby mode, as indicated by the amber color of the **Power Indicator 3**. Once the unit is in standby, you may begin a listening session by pressing the **System Power Control 2** on the front panel or the **Main Power On** button **A** on the remote. Note that the **Power Indicator 3** will turn red, then blue. This will turn the unit on and return it to the input source that was last used. The unit may also be turned on from standby by pressing any of the **Source Selector** buttons on the front panel **8 9 11 13 14 17 24** or remote **C**.

To turn the unit off at the end of a listening session simply press the **System Power Control 2** on the front panel or the **Main Power Off** button **B** on the remote. This places the unit in the Standby mode, and the **Power Indicator 3** will turn amber to remind you that the unit is ready for operation when a power command is received from the remote.

Power to any equipment plugged into the rear panel **Switched AC Outlet 19** will be shut off.

When the remote is used to turn the unit "off", it is actually placing the system in a standby mode, as indicated by the amber color of the **Power Indicator 3**.

- To dim the brightness of the front panel display, press the **Dimmer** button **H** on the remote or on the front panel **16**. The first press will dim the lights to half normal. A second press will turn the display completely off. Press the **Dimmer** button **H16** again to restore the display to normal brightness.

Source Selection

- To select a source at any time, press any of the **Source Selector** buttons on the remote **C** or front panel **8 9 11 13 14 17 24**.
- When a video source is selected, if you have connected a video device to the video input jack for that source, and if you have connected the

Video Monitor Output 2 to the composite video input of your TV or video display, you will be able to enjoy video programs from a broadcast, cable or satellite television system; a VCR or hard-disk video recorder; a DVD player; or any other video device with analog line-level audio outputs and a composite video output.

NOTE: Although the HK 3480 is an audio/video receiver, it is not a surround sound receiver. Audio will be played in two-channel stereo or monaural, depending on how the program material is encoded, and you will not be able to hear any additional channels that may be encoded in your source materials. You will not be able to make any digital audio connections through the HK 3480. The HK 3480 is designed to provide video entertainment in a small system application that includes devices such as a TV, VCR or DVD player located in a bedroom, office or spare room, or as part of a multi-room system when used with a multiroom controller.

To take advantage of Harman Kardon's exclusive VMaX mode, Press the **VMaX** button **16 AA**. When the VMaX circuits are engaged, patented processing algorithms are used to create a three-dimensional sound space with the illusion of "phantom" speakers at center and surround positions. This spacious sound will simulate a surround-sound presentation without the need to add additional speakers. To return to standard stereo listening, press the **VMaX** button **16 AA** again and note that the **VMaX Mode Indicator 26** will go out. (For more information on maximum benefit with VMaX see page 11, item **AA**).

- During a listening session you may wish to adjust the **Bass 20**, **Treble 21** and **Balance 22** controls to suit your listening tastes.
- Adjust the volume to a comfortable level using the front panel **Volume Control 23** or remote **Master Volume Up/Down P** buttons. The volume level is displayed as a negative number of decibels (dB) in the **Main Information Display 25**. The volume level is relative to a maximum volume level that has been assigned the value of 0dB. It is important that you make sure never to exceed this maximum volume level (0dB) at any time, in order to avoid possible damage to your loudspeakers due to "clipping", a type of distortion that is not audible to the human ear until it is severe enough to permanently damage most loudspeakers. It is also possible, depending upon the program material, for clipping to occur at volumes below the maximum volume level.

- To temporarily silence all speaker outputs, press the **Mute** button **R5**. This will cut the output to all Pre and Sub Outs and to all speakers, but it will not affect any recording or dubbing that may be in progress. When the system is muted, the **MUTE** indicator will light in the **Main Infor-**

mation Display 25 and the **Volume/Mute** indicator **24** will flash. Press the **Mute** button **R5** again to return to normal operation.

- For private listening, plug the 6,3 mm stereo phone plug from a pair of stereo headphones into the front panel **Headphone** jack **4**.
- One or two separate sets of speakers may be connected to the HK 3480. To listen to one of the speaker sets, press the **Speaker** button **6** or **7** on the front panel corresponding to the desired speakers or press them both to listen to both speakers pairs. The active speakers will be indicated by a lit blue LED in the **Speaker Indicators 26** display. Both sets of speakers may be turned off for private headphone listening.

IMPORTANT NOTE: When two speaker pairs are connected to the HK 3480 and are to be used simultaneously, the impedance of each speaker must not be lower than 8 Ohms.

- To program the HK 3480 for automatic turn-off, press the **Sleep** button on the front panel **19** or remote **C**. Each press of the button will increase the time before shutdown in the following sequence:

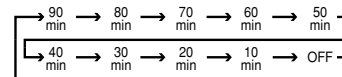

The sleep time will be displayed in the **Main Information Display 25** and it will count down until the time has elapsed.

When the programmed time has elapsed, the unit will automatically turn off (to Standby mode). Note that the front panel display will dim to one-half brightness when the Sleep function is programmed. To cancel the Sleep function, press the **Sleep** button **19 C** or simply hold it pressed for some seconds until the Sleep indicator numbers disappear and the Main Information Display shows the current source. Pressing any control button while the Sleep control is activated will momentarily return the Main Information Display to full brightness for increased legibility without interrupting the Sleep function.

Tuner Operation

The HK 3480's tuner is capable of tuning AM, FM and FM Stereo broadcast stations. Stations may be tuned manually or automatically, or they may be stored as favorite station presets and recalled from a 30-position memory.

Station Selection

1. Press the **AM/FM 17** buttons on the front panel or on the remote **C** to select the tuner as an input.
2. Press these buttons again at any time to switch between AM and FM.

Operation

3. To automatically search for the next higher- or lower-frequency station that has an acceptable signal hold the **Tuning II▶** or **◀II** button **10** on the front or **1** or **7** on the remote pressed and release it as soon as the tuner starts the frequency search. To tune to the next station, press the button again. Tap the **Tuning** button to advance one frequency increment at a time, or press and hold it to locate a specific station. When the **TUNED** indicator lights, the station is properly tuned and should be heard with clarity.

4. Stations may also be tuned directly by pressing the **Direct** button **1**, and then pressing the **Numeric Keys** **2-9** that correspond to the station's frequency. The desired station will automatically be tuned.

NOTE: When the FM reception of a stereo station is weak, audio quality will be increased by switching to Mono mode by pressing the **FM Mode** button **18 S** until the **STEREO** indicator goes out.

Preset Tuning

Up to 30 stations may be stored in the HK 3480's memory for easy recall using the front panel controls or the remote. In order to program preset stations into memory, you must use the remote control.

To enter a station into the memory, first tune the station using the steps outlined above. Then:

1. Press the **Memory** button **6** on the remote. Note that the **MEMO** and **PRESET** indicators will light and flash in the Main Information Display.

2. Within five seconds, press the **Numeric Keys** **2-9** corresponding to the location where you wish to store this station's frequency.

For all preset numbers above "3" the station will be stored directly. Note that for the presets 1, 2 or 3 either you press the corresponding number and wait for 5 seconds or you press a "0" before you press the 1, 2 or 3, then the station will be stored at once.

3. Repeat the process after tuning any additional stations to be preset.

Auto Preset

• Preset stations may also be programmed automatically for the entire FM band. To automatically enter each station that may be tuned with acceptable quality into the HK 3480's preset memories, first select the FM band. Next, press and hold the **Auto Preset** button **1** until the **MEMO** and **PRESET** indicators begin to flash, hold on until the station frequency indication begins to increase. Release the button and note that the tuner will search the entire FM band, and stop briefly at each station that has acceptable signal strength. The HK 3480 will automatically assign a preset number to each station, and then search for the next station.

If the FM tuner finds fewer than 30 FM stations with acceptable signal strength, the Auto Preset

tuning will scan up to two more cycles until the remaining vacant preset memory spaces have been filled.

The automatic scan process will stop when all 30 preset memory locations have been filled or the entire FM band has been scanned three times or the **Auto Preset** button **1** is pressed again.

NOTE: Using the automatic tuning mode in areas with more than 30 FM stations will completely fill the preset memories, and overwrite any previously memorized presets for either AM or FM stations.

TIP: The automatic scan process may enter stations that you do not wish to retain in the memory, or it may enter the same station on the same frequency (if more than one scan is made) or on more than one frequency. These unwanted stations may be removed from the memory using the Preset Clear function outlined below.

Recalling Preset Stations

• To manually select a station previously entered in the preset memory, press the **Numeric Keys** **2-9** that correspond to the desired station's memory location.

• To manually tune through the list of stored preset stations one by one, press the **Preset** buttons **15 D** on the front panel or remote.

• To automatically scan through the stations entered in the preset memory, press the **Preset Scan** button **12 @** on the front panel or remote. The tuner will cycle through the list of preset stations, stopping for five seconds at each one. Press the button again to stop the scan at your desired station.

Clearing Preset Stations

Unwanted preset stations may be erased from the unit's memory to make it easier to tune only those stations you want.

To remove a preset station from the HK 3480's tuner memory, first tune to the station using the **Preset** buttons **15 D** on the front panel or remote, or by entering the preset number directly, using the **Numeric Keys** **2-9**.

When the preset station to be removed has been tuned, first press the **Memory** button **6**. The **MEMO** and **PRESET** indicators in the Main Information Display will flash, and the actual preset number will disappear from the display. Next, press the **Clear** button **1** within five seconds.

The preset station will be removed from the memory, and the action will be confirmed by the brief appearance of the word **CLEAR** and the preset number location in the Main Information Display. That memory location will now be empty, and you may program a different station to that location, or leave it empty.

RDS Operation

RDS (Radio Data System) transmits station call signs or network information, station program type, text messages about the station or specifics of a musical selection and the correct time.

RDS Tuning

When an FM station is tuned in and it contains RDS data, the HK 3480 will automatically display the station's call sign, with some private stations also other informations changing all 2 to 5 seconds, and the **RDS** indicator will light in the Information Display as well as indicators for the RDS services program type **PTY** (see below) and traffic announcement **TA** (see page 14) if transmitted by the station. As soon as a radiotext message is received completely the radiotext indicator **RT** will turn on too.

RDS Display Options

When an RDS station is tuned, press **RDS Display** button **7** on the remote or **FM 17** on the front panel to cycle through the RDS displays in the following order:

- The Station name (or other Program information with some private stations).
- The station's frequency.
- The Program Type (PTY) as shown in the following list in this manual.
- A "text" message (RT) containing special information from the broadcast station. Note that this message will scroll across the display to permit messages longer than the eight positions in the display. Depending on signal quality it may take up to 30 seconds for the text message to appear, in the meantime the word **TEXT** will flash in the display when RT is selected.
- The current time of day (CT) as transmitted by the station. It may take up to two minutes for the time to appear, in the meantime the word **TIME** will flash in the display when CT is selected. Note that the accuracy of the time message is set by the radio station, not the HK 3480.
- Some RDS stations may not choose to include some of these additional features. If the data required for the selected mode is not being transmitted, the **Information Display** will show a **NOPTY, NO TEXT** or **NO TIME** message after the individual time out.
- In any FM mode the RDS function requires a strong enough signal for proper operation. If you receive a partial message or see any RDS indicator going on and off, try slowly adjusting the antenna to improve the signal strength or tune to another, stronger, RDS station.

Operation

Program Search (PTY)

A major benefit of RDS is its ability to encode broadcasts with Program Type (PTY) codes that indicate the type of material being broadcast. The following list shows the abbreviations used to indicate each PTY along with an explanation of the PTY:

- **RDS ONLY**: (see item 3 below)
- **TRAFFIC**: Traffic Information and Road Conditions (see Note below)
- **POPM**: Popular Music
- **ROCKM**: Rock Music
- **MORM**: Middle-of-the-Road Music
- **LIGHTM**: Classical Music
- **CLASSICS**: Serious Classical Music
- **OTHERM**: Other Music
- **NEWS**: News
- **INFO**: Information
- **SPORT**: Sports
- **AFFAIRS**: Current Affairs
- **EDUCATE**: Educational
- **DRAMA**: Drama
- **CULTURE**: Culture
- **SCIENCE**: Science
- **VARIED**: Varied Speech Programs
- **WEATHER**: Weather Information
- **FINANCE**: Financial Programs
- **CHILDREN**: Children's Programs
- **SOCIAL**: Social Affairs Programs
- **RELIGION**: Religious Broadcasts
- **PHONE IN**: Phone-In Programs
- **TRAVEL**: Travel and Touring
- **LEISURE**: Leisure and Hobby
- **JAZZ**: Jazz Music
- **COUNTRY**: Country Music
- **NATIONM**: National Music
- **OLDIES**: Oldies Music
- **FOLKM**: Folk Music
- **DOCUMENT**: Documentary Programs
- **TEST**: Station Alarm Test Message
- **ALARM**: Emergency Broadcast Information

You may search for a specific Program Type (PTY) by following these steps:

1. Press the **RDS PTY** button **2** and note that the Information Display will show **SELECT PTY**.
2. After three seconds, the display will show the PTY that was selected for the last PTY search. If you wish to use the same PTY, press the **RDS PTY** button **2** again within six seconds, and the tuner will begin to search for the first station with

the appropriate PTY and acceptable signal strength.

3. To search for a different PTY, press the **Tuning Up/Down** buttons **1** **10** while the last PTY selected is still displayed to scroll through the list of available PTY types. To search for the next available station with any RDS data, select **RDS ONLY** as the PTY type.

4. When the PTY is selected, press the **RDS PTY** button **2** within six seconds, and note the **PTY** indicator will flash in the Information Display. The HK 3480 will go into an automatic search mode and attempt to find the next station with acceptable signal strength that matches the desired PTY type. Press the **RDS PTY** button **2** twice again to find another matching station. When a station is tuned, the search will stop, a message **RDS** will blink in the **Information Display** and then the Display will show the station's "Call Letters" or other "Program Service" information.

5. While the **PTY Indicator** flashes in the display the tuner will make one complete scan of the entire FM band for the text station that matches the desired PTY type and has acceptable reception quality. If no such station is found, the word **NONE** will appear briefly in the Information Display, and the tuner will return to the last FM station in use before the search.

To turn off the PTY Search at any time, press the **RDS PTY** button **2** again.

NOTE: Many stations do not transmit a specific PTY. The display will show **NONE**, when such a station is selected and PTY is active.

NOTE: Some stations transmit constant traffic information. To identify as traffic station, they transmit a specific traffic code constantly, which causes the **TA Indicator** to light in the display. These stations can be found by selecting **TRAFFIC**, the second option in the PTY list. The HK 3480 will find the appropriate station, even if it is not broadcasting traffic information when the search is made.

Tape Recording

In normal operation, the audio source selected for listening through the HK 3480 is sent to the **Tape Mon Rec Out 10** and **Video 1 Record Outputs 11** outputs. This means that any program you are listening to may be recorded simply by placing machines connected to the outputs for **Tape Monitor 10** or **Video 1 11** in the record mode. Moreover the source connected to **Video 1 Input 8** may be recorded to a recorder connected to **Tape Mon 9 10**, rather than turned around.

When a tape recorder with separate record and playback heads is used, you may monitor the output of the recording by selecting the **Tape Monitor Input Selector 9 C**. Note that the

TAPE M. Indicator will light in the **Main Information Display 25** to remind you that you are listening to the record playback instead of the actual input source being recorded.

As long as **Tape Monitor 9 C** is selected the previously selected input source remains routed to the **Record Outputs 10 12**. Press the **Tape Monitor Input Selector 9 C** again to turn the monitoring off and listen to the actual input source. Note that changing the Bass, Treble or Balance control will not affect the recordings, only the preamp and speaker outputs.

Memory Backup

This product is equipped with a memory backup system that preserves tuner presets if the unit is accidentally unplugged, turned off completely by disconnecting from the main power source or subjected to a power outage.

The unit's memory is stored in an EEPROM, and thus the HK 3480 will retain information such as programmed presets for a virtually infinite time without being connected to a main power source.

Processor Reset

In the rare case where the unit's operation or the displays seem abnormal, the cause may involve the erratic operation of the system's memory or microprocessor.

To correct this problem, first unplug the unit from the AC wall outlet and wait at least three minutes. After the pause, reconnect the AC power cord and check the unit's operation. If the system still malfunctions, a system reset may clear the problem.

To reset the system, first turn the HK 3480 off by pressing the by disconnecting from the main power source.

Next, press and hold the **MUTE Button 5** on the front panel ONLY.

The Main Information Display will briefly show the word **RESET**, you can release the button pressed now, the unit will return to Standby mode.

Note that when the system is reset in this fashion, all tuner presets will be lost and must be reentered.

If the system is still operating incorrectly, there may have been an electronic discharge or severe AC line interference that has corrupted the memory or microprocessor.

If these steps do not solve the problem, consult your dealer or an authorized Harman Kardon service center.

Operation

Using the Remote Control

It is convenient to think of the functions of the remote control buttons in terms of "pages", where each source device (e.g. CD player) represents its own page of remote functions. The result is that some of the keys will perform different functions depending upon which device page has been selected prior to pressing the key. Device pages are selected by pressing the

Source Selectors , which also changes the input source selection on the HK 3480.

Source Selectors  need not to be pressed with each function, but only when you intend to skip to another device to be controlled.

The Video 1, Video 2, Video 3, Tape Monitor/CDR and CD device pages are factory-programmed to operate compatible Harman Kardon products.

The Video 1, Video 2 and Video 3 device pages are programmed at the factory to default to Harman Kardon DVD player control codes. The Tape Monitor/CDR page defaults to Harman Kardon CD-R control codes. The CD page defaults to Harman Kardon CD player or changer control codes. Please refer to the table below for specific information on the default functions of the affected keys for these devices.

REMOTE BUTTON FUNCTIONS

BUTTON	PHONO Controls HK 3480 only	VID 1 DVD Player Control Codes	VID 2 DVD Player Control Codes	VID 3/VID Front DVD Player Control Codes	TAPE MON/CDR CD Recorder Control Codes	CD CD player/changer Control Codes	AM Controls HK 3480 tuner only	FM Controls HK 3480 tuner only
MAIN POWER ON	System Power On	System Power On	System Power On	System Power On	System Power On	System Power On	System Power On	System Power On
MAIN POWER OFF	System Power Off	System Power Off	System Power Off	System Power Off	System Power Off	System Power Off	System Power Off	System Power Off
SPEAKERS 1	Speakers 1	Speakers 1	Speakers 1	Speakers 1	Speakers 1	Speakers 1	Speakers 1	Speakers 1
SPEAKERS 2	Speakers 2	Speakers 2	Speakers 2	Speakers 2	Speakers 2	Speakers 2	Speakers 2	Speakers 2
PHONO	Phono	Phono	Phono	Phono	Phono	Phono	Phono	Phono
TAPE/CDR	Tape Mon/CDR	Tape Mon/CDR	Tape Mon/CDR	Tape Mon/CDR	Tape Mon/CDR	Tape Mon/CDR	Tape Mon/CDR	Tape Mon/CDR
VID 1	VID 1	VID 1	VID 1	VID 1	VID 1	VID 1	VID 1	VID 1
VID 2	VID 2	VID 2	VID 2	VID 2	VID 2	VID 2	VID 2	VID 2
VID 3	VID 3	VID 3	VID 3	VID 3/VID Front	VID 3	VID 3	VID 3	VID 3
CD	CD	CD	CD	CD	CD	CD	CD	CD
AM	AM	AM	AM	AM	AM	AM	AM	AM
FM	FM	FM	FM	FM	FM	FM	FM	FM
PRESET DWN I<<		DVD OSD Back	DVD OSD Back	DVD OSD Back	CDR Skip Up	CD Track Skip +	Preset Tuning Up	Preset Tuning Up
PRESET UP >>I		DVD OSD Forward	DVD OSD Forward	DVD OSD Forward	CDR Skip Down	CD Track Skip –	Preset Tuning Down	Preset Tuning Down
TUNING DWN <<		DVD Search Reverse	DVD Search Reverse	DVD Search Reverse	CDR Search Reverse	CD Search Reverse	Tuning Down	Tuning Down
TUNING UP >>		DVD Search Forward	DVD Search Forward	DVD Search Forward	CDR Search Forward	CD Search Forward	Tuning Up	Tuning Up
REC/PAUSE		DVD Pause	DVD Pause	DVD Pause	CDR Record	CD Pause		
STOP		DVD Stop	DVD Stop	DVD Stop	CDR Stop	CD Stop		
ENTER		DVD Enter	DVD Enter	DVD Enter	CDR Random Play	CD Random Play		
PLAY		DVD Play	DVD Play	DVD Play	CDR Play	CD Play		
DISC SKIP UP		DVD Disc Skip +	DVD Disc Skip +	DVD Disc Skip +	CDR Disc Skip +	CD Disc Skip +		
DISC SKIP DOWN		DVD Disc Skip –	DVD Disc Skip –	DVD Disc Skip –	CDR Disc Skip –	CD Disc Skip –		
FM MODE		DVD Menu	DVD Menu	DVD Menu	CDR Time	CD Display Mode	FM Mode	FM Mode
VMAx	VMAx	VMAx	VMAx	VMAx	VMAx	VMAx	VMAx	VMAx
P. SCAN		DVD Intro Scan	DVD Intro Scan	DVD Intro Scan	CDR Intro Scan	CD Intro Scan	Preset Scan	Preset Scan
MUTE	Audio Mute	Audio Mute	Audio Mute	Audio Mute	Audio Mute	Audio Mute	Audio Mute	Audio Mute
SLEEP	Sleep Timer	Sleep Timer	Sleep Timer	Sleep Timer	Sleep Timer	Sleep Timer	Sleep Timer	Sleep Timer
DIMMER	Dimmer	Dimmer	Dimmer	Dimmer	Dimmer	Dimmer	Dimmer	Dimmer
TUNING UP		DVD OSD Up	DVD OSD Up	DVD OSD Up	CDP Select		Tuning Up	Tuning Up
TUNING DOWN		DVD OSD Down	DVD OSD Down	DVD OSD Down	CDR Select		Tuning Down	Tuning Down
MASTER VOL. UP	Volume Up	Volume Up	Volume Up	Volume Up	Volume Up	Volume Up	Volume Up	Volume Up
MASTER VOL. DOWN	Volume Down	Volume Down	Volume Down	Volume Down	Volume Down	Volume Down	Volume Down	Volume Down
DIRECT						CD +10	Frequency Direct	Frequency Direct
AUTO PRESET						CD Program Check	Auto Preset	Auto Preset
MEMORY						CD Program	Momory/Store	Momory/Store
CLEAR						CD Clear	Preset Clear	Preset Clear
1						CD 1	Memo 1	Memo 1
2						CD 2	Memo 2	Memo 2
3						CD 3	Memo 3	Memo 3
4						CD 4	Memo 4	Memo 4
5						CD 5	Memo 5	Memo 5
6						CD 6	Memo 6	Memo 6
7						CD 7	Memo 7	Memo 7
8						CD 8	Memo 8	Memo 8
9						CD 9	Memo 9	Memo 9
0						CD 0	Memo 0	Memo 0

Troubleshooting Guide

This unit is designed for trouble-free operation. Most problems users encounter are due to operating errors. If you have a problem, first check this list for a possible solution. If the problem persists, consult your authorized Harman Kardon Service Center.

If the problem is...	Make sure that the...
No lights appear when System Power 2 button is pressed	Unit is plugged into a live outlet.
No sound is heard	Unit has not been muted. Correct input function selector button has been pressed. Volume is turned up. Speakers have been turned on using the Speaker Selectors 6 7 U V .
No output from one or more channels	Cables are not defective: check/replace speaker cables.
Tuner sound has a large amount of interference, or the "Stereo" display is not illuminated, or Tuner sound distorts and/or is noisy	Antenna is properly connected. Antenna is properly located. Antenna is set in the proper direction. Antenna is adequate to receive the desired station.
Tuner is intermittent or continuously buzzing or hissing	Unit is away from fluorescent lights, TVs, motors and other electrical appliances.
Remote does not function correctly	Batteries are not weak, and replace them if necessary. Correct device page has been selected by pressing the Source Selector key C . Remote sensor is not obstructed, and remote is pointing directly at sensor at an angle of no more than 30 degrees. Also, check for fluorescent lighting, which may be interfering with the IR transmission.
Cassette or CD sounds distorted	Cassette deck or CD player has not been plugged into the Phono input. (Only use the outputs of a turntable or tonearm with the Phono input.)
Turntable sounds distorted	Turntable has been plugged into the Phono Input 6 , as the other inputs are not compatible with turntable signal levels
No video image	Video source unit's video output is properly connected, the source is turned on and the correct video input on the HK 3480 has been selected Video Monitor Output 4 is connected to a TV or video display, and that the TV is turned on and the proper input on the TV has been selected

Technical Specifications

Audio Section

Stereo Mode	
Continuous Average Power (FTC)	
120 Watts per channel, 20Hz–20kHz	
@ < 0.07% THD, both channels driven into 8 ohms	
150 Watts per channel, 20Hz–20kHz	
@ < 0.2% THD, both channels driven into 4 ohms	
Input Sensitivity/Impedance	
Linear (High Level)	200mV/47kohms
Signal-to-Noise Ratio (IHF-A)	95dB
Frequency Response	
@ 1W (+0dB, -3dB)	10Hz–110kHz
High Instantaneous Current Capability (HCC)	±45 Amps
Transient Intermodulation Distortion (TIM)	Unmeasurable
Rise Time	16 µsec
Slew Rate	40V/µsec

FM Tuner Section

Frequency Range	87.5–108MHz
Usable Sensitivity	IHF: 1.12 µV/13.5dBf
Signal-to-Noise Ratio	Mono/Stereo: 73/72dBA (DIN)
Distortion	Mono/Stereo: 0.3/0.4%
Stereo Separation	40dB @ 1kHz
Selectivity	±400kHz, 65dB
Image Rejection	>80dB
IF Rejection	>100dB

AM Tuner Section

Frequency Range	522–1620kHz
Signal-to-Noise Ratio	>40dB
Usable Sensitivity	Loop: 500 µV/M
Distortion	1kHz, 50% Mod: 0.8%
Selectivity	±10kHz: >25dB

Video Section

Television System	NTSC/PAL/SECAM
Signal Format	Composite
Input Level	1Vp-p
Input Impedance	75 ohms, unbalanced
Sync Polarity	Negative
Output Level	1Vp-p
Output Impedance	75 ohms, unbalanced
Video Frequency Response	10Hz – 10MHz

General

Power Requirement	AC 230V/50Hz
Power Consumption	3W standby, 280W maximum (both channels driven)

Dimension (Max)

Width	442mm
Height	168mm
Depth	382mm
Weight	10.4kg

Depth measurement includes knobs, buttons and terminal connections. Height measurement includes feet and chassis.

All features and specifications are subject to change without notice.

Harman Kardon and Power for the Digital Revolution are registered trademarks of Harman International Industries, Incorporated.

harman/kardon

H A Harman International Company
250 Crossways Park Drive, Woodbury, New York 11797
www.harmankardon.com
Harman Consumer International:
2, Route de Tours, 72500 Château-du-Loir, France
© 2003 Harman Kardon, Incorporated
Part CQX1A890Z