



**Assembling
and Using Your...**

Heathkit

**DIRECT READING
CAPACITY METER**

MODEL CM-1

HEATH COMPANY

A Subsidiary of Daystrom Inc.

BENTON HARBOR, MICHIGAN

ASSEMBLY AND OPERATION OF THE HEATHKIT DIRECT READING CAPACITY METER MODEL CM-1



*Jeans & Co except
I instead of 1.5V
at first prints -
repl. caps. Tubes
seen OK*

SPECIFICATIONS

Ranges.....	100-1000 $\mu\mu\text{f}$; .01-.1 μfd full scale
Tubes.....	6BX7GT Oscillator 6X5GT Rectifier OA2 Voltage Regulator
Meter.....	Easy to read 4 1/2" meter with linear scale and streamlined case; 50 microampere movement
Calibrating Condensers.....	$\pm 1\%$ for 100 and 1000 $\mu\mu\text{f}$ ranges $\pm 2\%$ for 0.01 and 0.1 μfd ranges
Power Requirements.....	105-125 volts AC, 50/60 cycles, 25 watts
Dimensions.....	7 3/8" high x 4 11/16" wide x 4 1/8" deep
Net Weight.....	5 lbs.
Shipping Weight.....	7 lbs.

INSTRUMENT DESCRIPTION

The measurement of capacity is accomplished by rectifying a square sided pulse and reading the average value of the voltage on a meter. The impedance of the meter circuit in conjunction with the unknown capacity determines the shape and consequently, the average value of the rectified voltage.

A power transformer, in conjunction with a 6X5GT rectifier tube and an OA2 voltage regulator tube, supplies regulated voltage for the oscillator.

The oscillator uses a 6BX7GT tube in a cathode-coupled multivibrator circuit. A 100 Ω cathode resistor provides the common impedance necessary to maintain oscillation and is also the source impedance of the pulse used for the measurement of capacity. The range switch selects the value of feed-back capacity and the calibrating potentiometer. These values establish the pulse repetition rate and therefore the maximum capacity which can be read on that range. The frequencies used range from about 80 cps to 80 kc.

The pulse repetition rate is such that, at maximum deflection of the meter on any range, the waveform of the rectified pulse will have decayed to zero during the interval between pulses. This is necessary in order to maintain linearity of reading throughout the full range of the instrument.

NOTES ON ASSEMBLY AND WIRING

The Heathkit model CM-1 Direct Reading Capacity Meter, when properly constructed will provide a service and laboratory type instrument capable of many years of satisfactory operation. We urge you to take the necessary time to assemble and wire the instrument carefully. Do not hurry the work and you will be rewarded with a greater sense of confidence, both in the equipment and your own workmanship.

This manual is supplied to assist you in every way to complete the instrument with the least possible chance of error. We suggest that you take a few minutes now and read the entire manual carefully before any work is started. This will enable you to proceed with the work much faster and with greater accuracy. The large fold-in pictorials are handy to attach to the wall above your work space. Their use will greatly simplify the construction of the kit. These diagrams are repeated in smaller form within the manual. We suggest that you retain the manual in your files for future reference, both in the use and maintenance of the CM-1 Capacity Meter.

UNPACK THE KIT CAREFULLY AND CHECK EACH PART AGAINST THE PARTS LIST. In so doing, you will become acquainted with each part. Refer to the charts and other information shown on the inside covers of the manual to help you identify any parts about which there may be a question. If some shortage is found in checking the parts, please notify us promptly and return the inspection slip with your letter to us. Hardware items are counted by weight and if a few are missing, please obtain them locally if at all possible.

Read the note on soldering on the inside of the back cover. Crimp all leads tightly to each terminal before soldering. Be sure the lead and the terminal are clean of wax, corrosion or other foreign substances. Use only the best rosin core solder, preferably one containing the new activated fluxes, such as Kester "Resin Five," Ersin "Multicore" or similar types.

NOTE: ALL GUARANTEES ARE VOIDED AND WE WILL NOT REPAIR OR SERVICE INSTRUMENTS IN WHICH ACID CORE SOLDER OR PASTE FLUXES HAVE BEEN USED. WHEN IN DOUBT ABOUT SOLDER, IT IS RECOMMENDED THAT A NEW ROLL PLAINLY MARKED "ROsin CORE RADIO SOLDER" BE PURCHASED.

Resistors and controls generally have a tolerance rating of $\pm 10\%$ unless otherwise stated in the parts list. Therefore a $100\text{ K}\Omega$ resistor may test anywhere from $90\text{ K}\Omega$ to $110\text{ K}\Omega$. (The letter **K** is commonly used to designate a multiplier of 1000.) Tolerances on condensers are generally even greater. Limits of $+100\%$ and -50% are common for electrolytic condensers. The parts furnished with your Heathkit have been specified so as not to affect the operation of the finished instrument adversely.

In order to expedite delivery to you, we are occasionally forced to make minor substitutions of parts. Such substitutions are carefully checked before they are approved to insure that the parts supplied will work satisfactorily. By checking the parts list for resistors, for example, you may find that a 2.2 megohm resistor has been supplied in place of a 2 megohm as shown in the parts list. These changes are self-evident and are mentioned here only to prevent confusion to you in checking the contents of your kit.

Leads on condensers, transformers and resistors are generally much longer than they need be to make the indicated connections. In these cases, the excess leads should be cut off as the parts are added to the chassis. Not only does this make the wiring much neater, but in some cases the excessively long leads may actually impair proper operation of the instrument.

We strongly urge that you follow the wiring and parts layout shown in this manual. The desirable position of wires and parts has been previously determined for arrangement in logical sequence. Any changes may seriously affect the characteristics of the circuit or the operation of the completed instrument.

STEP-BY-STEP ASSEMBLY INSTRUCTIONS

The following instructions are presented in a simple, logical, step-by-step sequence to enable you to complete the kit with the least possible confusion. Be sure to read each step all the way through before you start to do it. When the step is completed, check it off in the space provided.

In assembling the kit, use lockwashers under all #6 nuts, except where solder lugs are used.

To facilitate describing the location of parts, they have been lettered and coded. All such numbering and lettering is clearly shown in the figures and when instructions read, for example, "Wire to B1," refer to the proper figure and connect a wire to pin 1 of socket B.

It is recommended that A, B, C, etc. be actually labeled on the chassis with a pencil. Lettering on the inside of the chassis where wiring is done will reduce the possibility of making wrong connections.

Tube socket pins are numbered as shown in Figure 11. Always read clockwise when the socket is viewed from the bottom.

When wiring the instrument, the letters (S) and (NS) will be encountered. (S) means solder the connection. (NS) means do not solder yet, as other wires will be added to the terminal.

STEP-BY-STEP ASSEMBLY

- () Mount an octal socket in location A. Use 6-32 screws, lockwashers and nuts. It may be necessary to bend the ground lug on the socket near the edge of the chassis. Refer to Figure 1.
- () Mount an octal socket in location B. Use 6-32 hardware.
- () Mount a 7-pin miniature socket in location C. Use 3-48 screws and nuts. Lockwashers are not used.
- () Mount a $3/8$ " rubber grommet in location D.
- () Mount a 1 megohm control in location E. Refer to Figure 2 for method of mounting controls and switches.

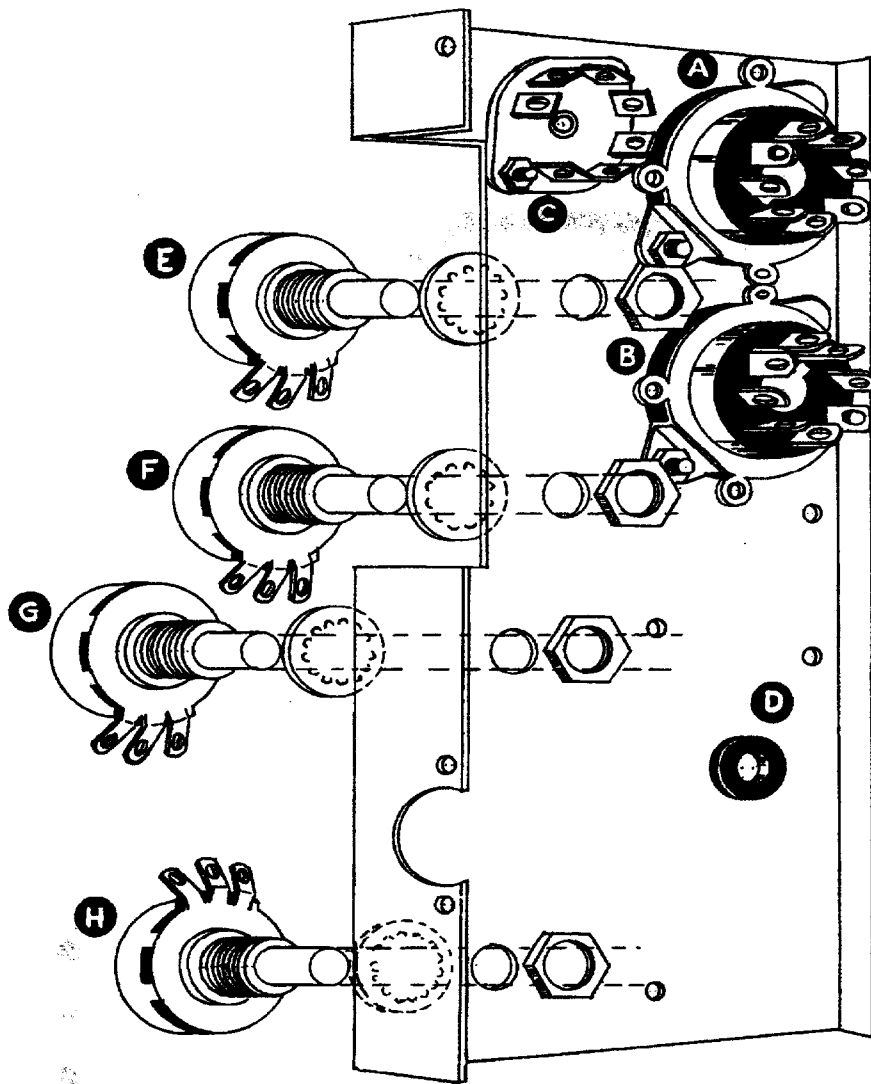

Figure 1. Chassis showing mounting of parts.

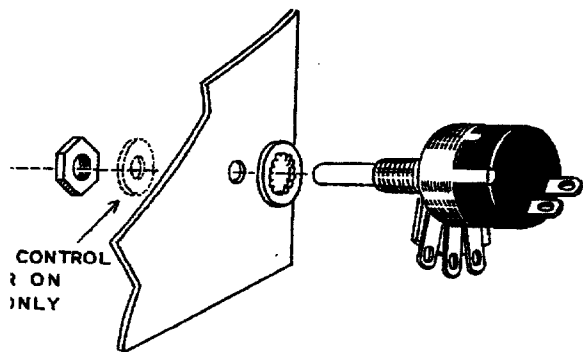

Figure 2. Control and switch mounting.

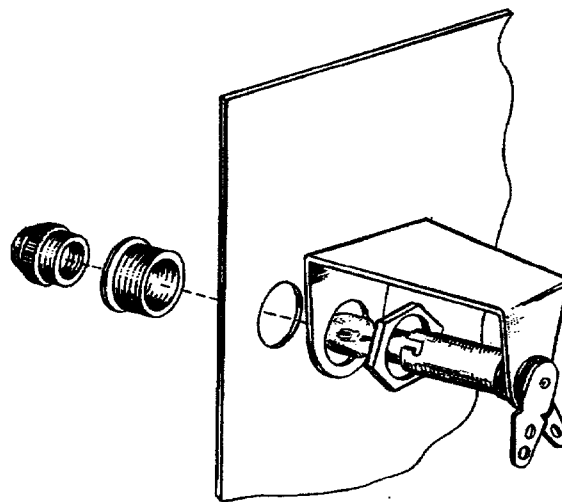

Figure 3. Pilot light mounting.

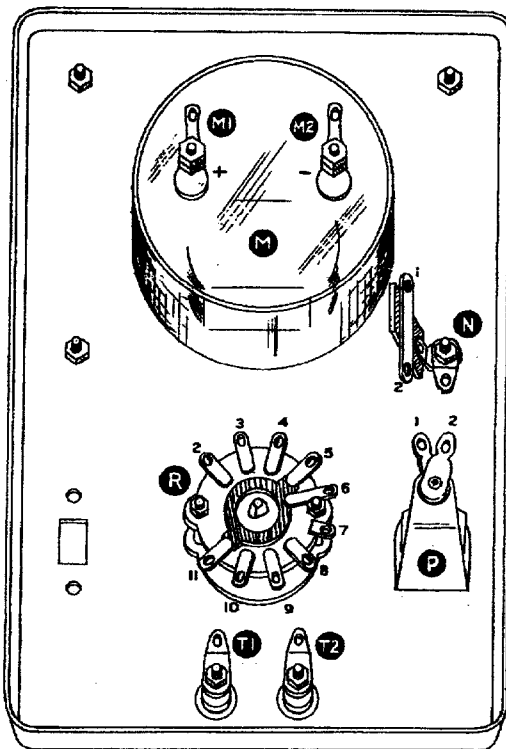

Figure 4. Panel showing mounting of parts.

- () Mount a 1 megohm control in location F.
- () Mount a 250 K Ω control in location G.
- () Mount a 100 K Ω control in location H.
- () Mount a pilot light socket assembly on the panel in location P. Refer to Figure 4 for the location and to Figure 3 on Page 5 for the method of mounting.
- () Mount the 4-position range switch in location R.

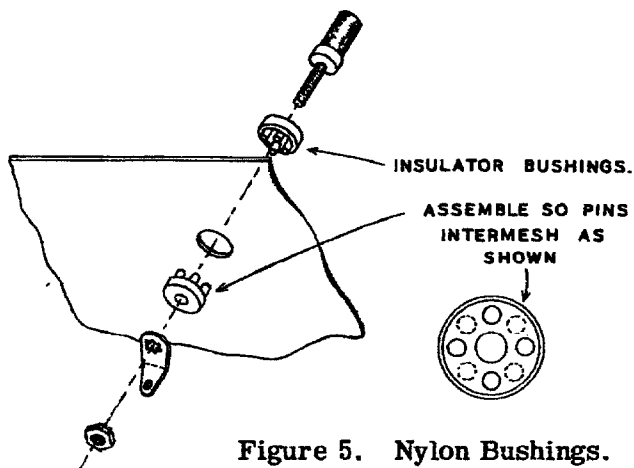

Figure 5. Nylon Bushings.

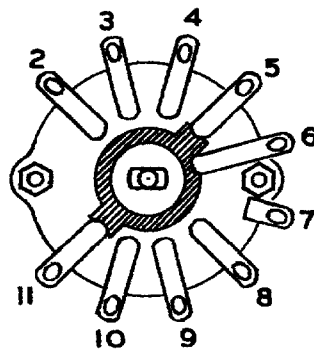

Figure 6. Range switch terminal numbering.

- () Mount the binding posts on the panel as shown in Figure 5, using a nylon bushing on each side of the panel. Use 6-32 hardware. Mount the red post in location T2 and the black post in location T1.

- () Mount the meter in location M using the hardware supplied with the meter. Under the nut in location N, mount a 1-lug terminal strip and a solder lug.
- () Connect one lead of a 0.1 μfd plastic tubular condenser to R2 on the range switch (S). Refer to Figure 6 for numbering of contacts on the switch. Any "outside foil" or "ground" markings on paper capacitors can be disregarded. They may be connected with either "polarity."
- () Connect the other lead of the condenser to N2 (NS).
- () Connect one lead of a 0.01 μfd plastic tubular condenser to R3 on the range switch (S).
- () Connect the other lead of the condenser to N2 (NS).
- () Connect one lead of a 1000 $\mu\mu\text{f}$ (.001 μfd) mica condenser to R4 of the range switch (S).
- () Connect the other lead of the condenser to N2 (NS).
- () Connect one lead of a 100 $\mu\mu\text{f}$ (.0001 μfd) mica condenser to R5 of the range switch (S).
- () Connect the other lead of the condenser to N2 (S).
- () Mount the chassis on the panel using the meter screw in location MG for the top bracket of the chassis. Under the nut mount a #6 solder lug. Refer to Figure 8.
- () Mount the SPST slide switch in location S. Use 6-32 screws, lockwashers and nuts. These screws pass through the panel, chassis and switch. Refer to Figure 8.

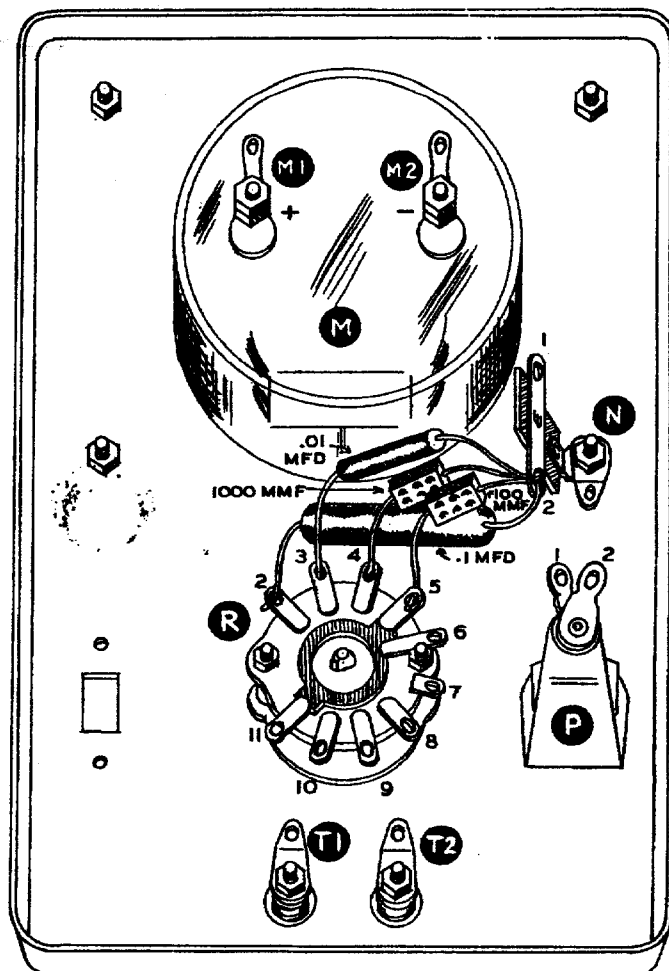

Figure 7. Range switch wiring.

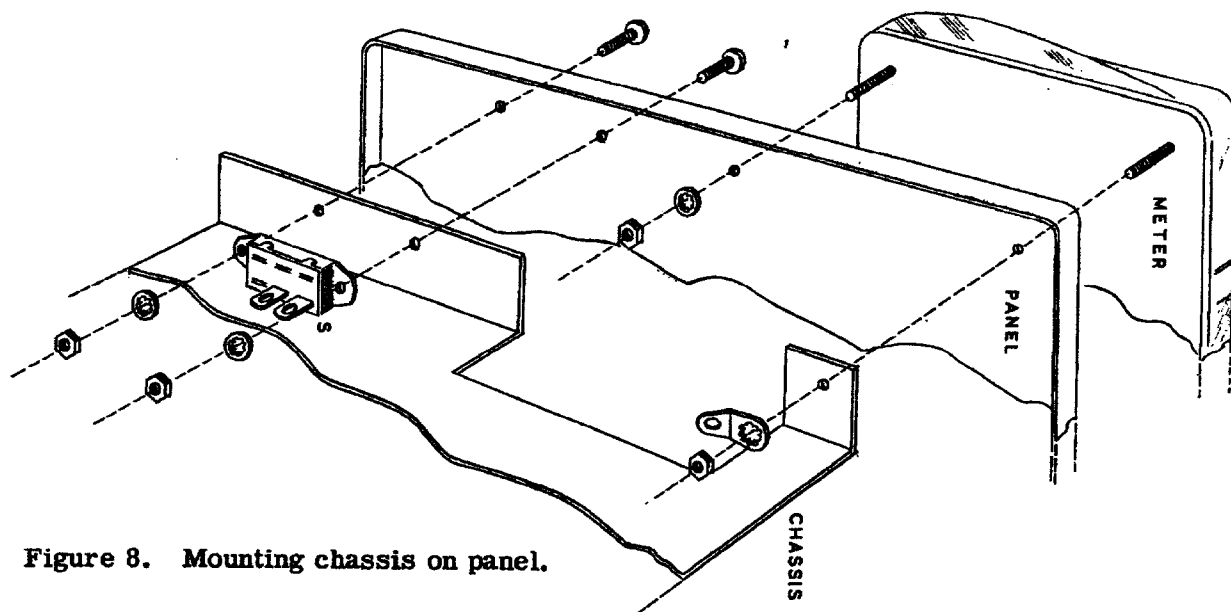

Figure 8. Mounting chassis on panel.

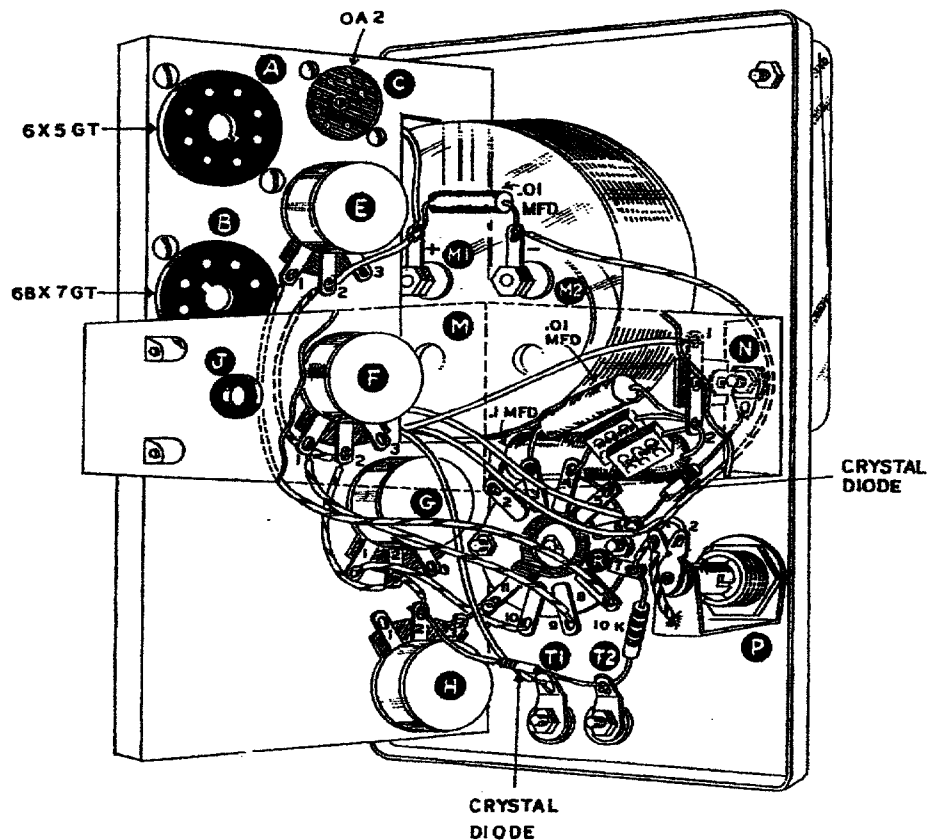

Figure 9. Wiring chassis - top.

- () Connect one end of an 8" length of hookup wire to T1 (S).
- () Strip 1 1/4" of insulation from the other end of the wire and connect it through B6 to B3 (NS). Now solder B6.
- () Connect a wire from H2 (NS) to G2 (NS).
- () Connect a wire from G2 (S) to F2 (NS).
- () Connect a wire from F2 (S) to E2 (NS).
- () Connect a wire from E2 (S) to M1 (NS).
- () Connect one lead of a 10 K Ω resistor to T2 (NS).
- () Connect the other lead of the resistor to R7 (NS).
- () Connect a wire from R7 (S) to M2 (NS).
- () Connect one lead of a 0.01 μ fd plastic tubular condenser to M2 (S).
- () Connect the other lead of the condenser to M1 (NS).
- () Connect a piece of wire from M1 (S) to MG (S).
- () Connect the cathode lead of a crystal diode to the H2 (S). See diode chart on Page 16 for correct identification of cathode end. Apply heat only long enough to make a good connection.

- () Connect the other lead of the crystal diode to T2 (S). Use technique outlined in preceding step.
- () Connect a wire from H3 (S) to R11 (S).
- () Connect a wire from G1 (S) to R10 (S).
- () Connect a wire from R9 (S) to F1 (S).
- () Connect a wire from R8 (S) to E1 (S).
- () Connect a wire from R6 (NS) to B4 (S).
- () Connect the cathode lead of a crystal diode to the ground lug N (S). See Chart on Page 16.
- () Connect the other lead of the crystal diode to R6 (S).
- () Connect a wire from N1 (S) to B2 (NS).
- () Connect a short piece of wire from P1 (S) to the frame of the pilot light socket (S).
- () Connect a wire from P2 (S) to B7 (NS).
- () Mount the power transformer in location W. Refer to Figure 12. Under the head of the screw in location W1, mount a solder lug and under the nut of the same screw, mount a 2-lug terminal strip. Under the nut in location W2, mount a solder lug.
- () Connect the red-yellow lead of the power transformer to the ground lug at W1 (NS).
- () Connect one of the green leads of the power transformer to the ground lug at W1 (S).
- () Dress the other green lead and the two red leads of the power transformer through the rubber grommet D.
- () Mount the chassis bracket as shown in Figure 10. Raise the 1-lug terminal strip and ground lug in location N and place the chassis bracket in position. Replace the terminal strip, solder lug and nut. Mount the other end of the bracket with 6-32 hardware as shown.

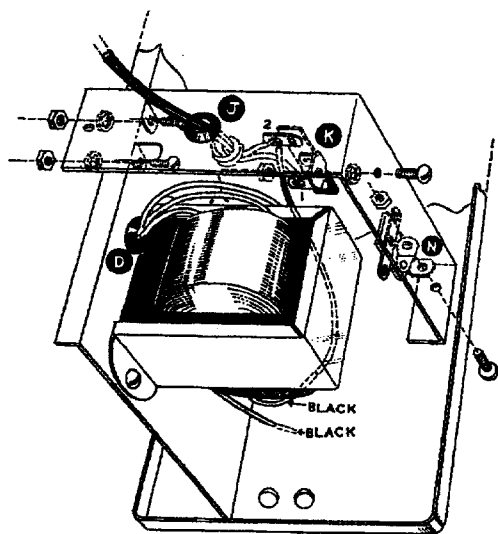

Figure 10. Mounting chassis bracket.

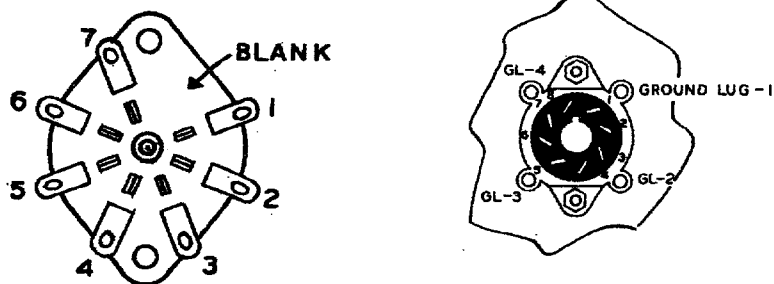

Figure 11. Socket pin numbering.

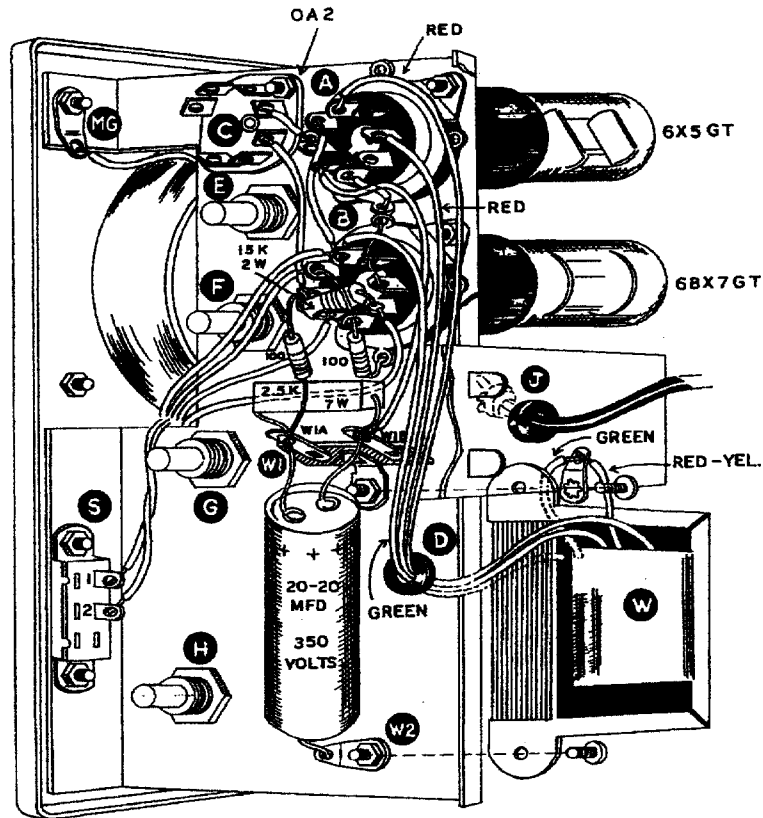

Figure 12. Wiring chassis.

- () Mount a 3/8" rubber grommet on the chassis bracket in location J.
- () Mount a 2-lug terminal strip on the chassis bracket in location K.
- () Connect a short wire from A7 (S) to GL4 on socket A (S). (Use bare wire.)
- () Connect a wire from W1E (NS) to A8 (S).
- () Connect a short wire from B1 (S) through B8 (S) to GL4 on socket B (S).
- () Connect one lead of a 100 Ω resistor to B3 (S).
- () Connect the other lead of the resistor to GL2 on socket B (S).
- () Connect one lead of a 15 K Ω 2 watt resistor to B2 (S).
- () Connect the other lead of the resistor to B5 (NS).
- () Connect a 100 Ω resistor from B5 (NS) to W1A (NS).
- () Connect a wire from B5 (S) to C5 (S).
- () Connect a wire from C4 (S) to GL1 (S) on socket A. (Use bare wire.)
- () Connect a wire from A2 (S) to B7 (NS).
- () Connect the green lead of the power transformer to B7 (S).
- () Connect one of the red leads of the power transformer to A3 (S).

- () Connect the other red lead of the power transformer to A5 (S).
- () Connect one of the positive leads (marked +) of the 20-20 μ fd 350 volt electrolytic condenser to W1A (NS).
- () Connect the other positive lead of the electrolytic condenser to W1B (NS).
- () Connect the negative lead of the electrolytic condenser to the ground lug at W2 (S).
- () Connect one lead of the 2.5 K Ω 7 watt resistor to W1A (S).
- () Connect the other lead of the resistor to W1B (S). Keep the resistor clear of the hole in the chassis bracket used for mounting the instrument in the cabinet.
- () Connect one end of a 7" length of hookup wire to K1 (NS).
- () Twist this piece of wire with one of the black leads from the power transformer and dress this twisted pair to switch S. Connect the black lead of this twisted pair to S1 (S).
- () Connect the other wire of this twisted pair to S2 (S).
- () Connect the other black transformer lead to K2 (NS).
- () Pass the line cord through the rubber grommet J. Tie a knot in the cord for strain relief.
- () Connect one lead of the line cord to K1 (S). Connect the other lead to K2 (S).
- () Mount the knob on the range switch using the 8-32 x 1/4 set screw. Be sure that the index corresponds to the correct setting of the switch.
- () Install the tubes in the proper sockets. Be especially careful in installing the OA2 as the pins of miniature tubes are easily bent.
- () Install the handle on the cabinet using the 10-24 screws.
- () Mount the rubber feet in the cabinet as shown in Figure 13.

Figure 13. Mounting rubber feet.



The instrument is now ready for preliminary testing and calibrating.

Before using the instrument, make sure that the four calibrating potentiometers are in full counterclockwise position as viewed from the shaft end. Damage to the meter may result if this is not done.

INITIAL ADJUSTMENTS AND CALIBRATION

Plug the line cord into a 105-125 volt 50-60 cycle AC outlet only. **SERIOUS DAMAGE TO THE TRANSFORMER WILL RESULT IF PLUGGED INTO A DC SUPPLY.** Turn on the power switch. The pilot light and the tubes will light up if the filament wiring is correct.

The meter should read zero on all ranges.

Two alligator clips and adapters with banana plugs are provided as test leads. These plug into the binding posts as shown in Figure 14 on Page 12.

Make sure all calibrating controls are in the extreme counterclockwise position before attempting to calibrate.

There are two possible calibration points for each range. The first one reached as the calibration control is turned clockwise from the extreme counterclockwise (shaft end) position is the correct one. That is, during calibration, the meter needle should be moving toward the maximum (right-hand end) of the scale.

Plug the test leads into the binding posts and clip the 100 $\mu\mu\text{f}$ silver mica $\pm 1\%$ capacitor between the clips. Set the RANGE switch on the 100 $\mu\mu\text{f}$ range. The meter should read approximately full scale. Adjust the bottom potentiometer (location H) until the meter reads just full scale.

Set the RANGE switch on the 1000 $\mu\mu\text{f}$ range and repeat the preceding procedure using the 1000 $\mu\mu\text{f}$ $\pm 1\%$ silver mica capacitor and the potentiometer next above (location G). Adjust again for full scale deflection of the meter. Repeat this procedure for the .01 μfd range, using the .01 matched pair and the potentiometer in location F. Repeat for the .1 μfd range, using the .1 μfd matched pair and the potentiometer in location E.

Leave the instrument on for several minutes and repeat the calibration on all the ranges. It may have changed slightly due to the warming up of the instrument.

After making these adjustments, install the instrument in the cabinet and fasten with two #6 self-tapping screws through the rear into the chassis bracket.

OPERATION

Plug in the cord and turn on the power switch.

Allow the instrument to warm up for at least five minutes.

Clip the unknown condenser across the terminals and read the value on the meter scale. Be sure the RANGE switch is on the proper scale. In case of doubt as to which range to use, start with the highest and work down until the proper range is found. If it is necessary to use leads of any appreciable length, the capacitance of the leads must be taken into consideration, especially on the low range. This is done by connecting the leads only to the instrument and reading the value on the meter. The leads are then connected to the unknown and another reading is made. The capacitance of the leads is then subtracted from the total reading to give the capacitance of the unknown. The capacitance of the test leads provided with the instrument is negligible.

IN CASE OF DIFFICULTY

1. Check the wiring by following each wire on the pictorial and in the instrument, inspecting the soldered connections on each end and then checking off that wire on the pictorial with a colored pencil. This will reveal mistakes and omissions in wiring, which is the most frequent cause of difficulties. Often having a friend check the wiring will reveal a mistake consistently overlooked.
2. Check the positions of the tubes and be sure they are in the proper position.
3. Check the tubes.

VOLTAGE CHART

SOCKET	TUBE	Pin 1	Pin 2	Pin 3	Pin 4	Pin 5	Pin 6	Pin 7	Pin 8
A	6X5GT	NC	6.3AC	210 AC	NC	210 AC	NC	0	240
B	6BX7GT	0	37	5AC	-15	150	5AC	6.3 AC	0
C	OA2	150	0	0	0	150	0	0	

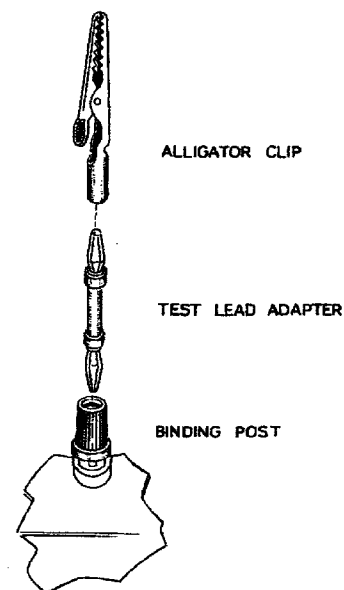

Figure 14. Test lead assembly.

4. Check the voltages between the tube socket terminals and chassis. The readings should come reasonably close to the values tabulated in the Voltage Chart, if a vacuum tube volt-meter with 11 megohm input impedance is used. Other type meters may give considerably lower reading. If a voltage reading fails to check with the tabulation, investigate the portion of the circuit involved by checking the resistors and condensers.

NC - no connection.

Unless otherwise indicated, all voltages are positive and measured to chassis.

Line voltage - 110 volts, 60 cycles.

RANGE switch in 100 μf position.

The current through the OA2 tube is approximately 15 MA on the 100 μf range and from 20-25 MA on the other three ranges. The total current through the 2.5 K Ω 7 watt filter resistor is about 50-55 MA.

If residual readings are present with nothing connected to the test terminals, make sure ground lugs N and MG are securely grounded. Also inspect the leads on all condensers connected to the range switch to make sure none of them are shorting to ground.

Instability on all ranges might be traced to a defective diode in the 6BX7 grid circuit. Component characteristics at this point are critical, although performance of the diode in the meter circuit is not. In some instances, exchanging the connections of the two diodes would be beneficial.

Instability on lower ranges only is usually caused by low line voltage. Observe the OA2 voltage regulator tube while rotating the range switch through all positions. If the tube fails to glow in one or more positions, it may be necessary to decrease the value of the 2.5 K Ω 7 watt resistor from W1A to W1B down to approximately 1 K Ω or 1.5 K Ω at 7 watts. Also check to make sure all calibration controls are near the counterclockwise end of rotation. If too far clockwise, the oscillator will draw high current, extinguishing the OA2.

If the instrument is to be left on over a prolonged period of time, it should be turned on for about 1/2 hour before attempting final calibration. The instrument should be in its cabinet so that all parts reach operating temperature. Each range can then be calibrated by slipping the instrument out of the cabinet and checked by placing the CM-1 back in the case again. Observing this procedure for all ranges will insure high accuracy. Exercise caution to avoid shorting the tube socket pins to the cabinet if this method is followed.

REPLACEMENTS

Material supplied with Heathkits has been carefully selected to meet design requirements and ordinarily will fulfill its function without difficulty. Occasionally improper instrument operation can be traced to a faulty tube or component. Should inspection reveal the necessity for replacement, write to the Heath Company and supply all of the following information:

- A. Thoroughly identify the part in question by using the part number and description found in the manual parts list.
- B. Identify the type and model number of kit in which it is used.
- C. Mention the order number and date of purchase.
- D. Describe the nature of defect or reason for requesting replacement.

The Heath Company will promptly supply the necessary replacement. Please do not return the original component until specifically requested to do so. Do not dismantle the component in question as this will void the guarantee. If tubes are to be returned, pack them carefully to prevent breakage in shipment as broken tubes are not eligible for replacement. This replacement policy does not cover the free replacement of parts that may have been broken or damaged through carelessness on the part of the kit builder.

SERVICE

In event continued operational difficulties of the completed instrument are experienced, the facilities of the Heath Company Service Department are at your disposal. Your instrument may be returned for inspection and repair for a service charge of \$3.00 plus the cost of any additional material that may be required. **THIS SERVICE POLICY APPLIES ONLY TO COMPLETED INSTRUMENTS CONSTRUCTED IN ACCORDANCE WITH THE INSTRUCTIONS AS STATED IN THE MANUAL.** Instruments that are not entirely completed or instruments that are modified in design will not be accepted for repair. Instruments showing evidence of acid core solder or paste fluxes will be returned not repaired.

The Heath Company is willing to offer its full cooperation to assist you in obtaining the specified performance level in your instrument. Factory repair service is available for a period of one year from the date of purchase or you may contact the Engineering Consultation Department by mail. For information regarding possible modification of existing kits, it is suggested that you refer to any one or more of the many publications that are available on all phases of electronics. They can be obtained at or through your local library, as well as at any electronic outlet store. Although the Heath Company sincerely welcomes all comments and suggestions, it would be impossible to design, test, evaluate and assume responsibility for proposed circuit changes for specific purposes. Therefore, such modifications must be made at the discretion of the kit builder according to information which will be much more readily available from some local source.

SHIPPING INSTRUCTIONS

Before returning a unit for service, be sure that all parts are securely mounted.

**ATTACH A TAG TO THE INSTRUMENT GIVING
NAME, ADDRESS AND TROUBLE EXPERIENCED.**

Pack in a rugged container, preferably wood, using at least three inches of shredded newspaper or excelsior on all sides. **DO NOT SHIP IN THE ORIGINAL KIT CARTON AS THIS CARTON IS NOT CONSIDERED ADEQUATE FOR SAFE SHIPMENT OF THE COMPLETED INSTRUMENT.** Ship by prepaid express if possible. Return shipment will be made by express collect. Note that a carrier cannot be held liable for damage in transit if packing, in HIS OPINION, is insufficient.

SPECIFICATIONS

All prices are subject to change without notice. The Heath Company reserves the right to discontinue instruments and to change specifications at any time without incurring any obligation to incorporate new features in instruments previously sold.

WARRANTY

Heath Company warrants that for a period of three months from the date of shipment, all Heathkit parts shall be free of defects in materials and workmanship under normal use and service and that in fulfillment of any breach of such warranty, Heath Company shall replace such defective parts upon the return of the same to its factory. The foregoing warranty shall apply only to the original buyer, and is and shall be in lieu of all other warranties, whether express or implied and of all other obligations or liabilities on the part of Heath Company and in no event shall Heath Company be liable for any anticipated profits, consequential damages, loss of time or other losses incurred by the buyer in connection with the purchase, assembly or operation of Heathkits or components thereof. No replacement shall be made of parts damaged by the buyer in the course of handling or assembling Heathkit equipment.

NOTE: The foregoing warranty is completely void and we will not replace, repair or service instruments or parts thereof in which acid core solder or paste fluxes have been used.

HEATH COMPANY

PARTS LIST

<u>PART No.</u>	<u>PARTS Per Kit</u>	<u>DESCRIPTION</u>	<u>PART No.</u>	<u>PARTS Per Kit</u>	<u>DESCRIPTION</u>
Resistors			Tubes-Diodes		
1-3	2	100 Ω	411-17	1	6X5GT
3-1E	1	2.5 KΩ 7 watt	411-59	1	OA2
1-20	1	10 KΩ	411-72	1	6BX7GT
1-4B	1	15 KΩ 2 watt	56-4	2	Crystal diode
			412-1	1	#47 pilot lamp
Condensers			Sheet Metal Parts		
20-32	1	100 μμf mica	90-26	1	Cabinet
20-13	1	100 μμf silver mica (±1% for calibration)	203-69F92	1	Panel
20-33	1	1000 μμf mica	200-M72	1	Chassis
20-17	1	1000 μμf silver mica (±1% for calibration)	204-M78	1	Chassis angle bracket
23-3	2	.01 μfd plastic tubular	Hardware		
23-64	1	.01 μfd matched pair .005 μfd (±2% for calibration)	250-2	2	3-48 x 1/4 machine screw
23-11	1	.1 μfd plastic tubular	250-8	2	#6 sheet metal screw
23-65	1	.1 μfd matched pair .05 μfd (±2% for calibration)	250-9	11	6-32 x 3/8 machine screw
25-30	1	20-20 μfd 350 volt elec.	250-83	2	#10 x 1/2 handle screw
Controls-Switches			252-1	2	3-48 hex nut
10-12	1	100 KΩ control	252-3	13	6-32 hex nut
10-14	1	250 KΩ control	252-7	5	Control nut
10-32	2	1 megohm control	253-10	1	Control flat washer
63-92	1	4-pos. rotary switch RANGE	254-1	10	#6 lockwasher
60-1	1	SPST slide switch	254-4	5	Control lockwasher
			259-1	6	#6 solder lug
Sockets-Terminals-Knobs			Miscellaneous		
434-2	2	Octal socket	73-1	2	3/8" rubber grommet
434-15	1	7-pin miniature socket	75-17	4	Nylon low-C bushing
434-22	1	Pilot light socket	100-M16B	1	Binding post cap, black
431-1	1	1-lug terminal strip	100-M16R	1	Binding post cap, red
431-2	2	2-lug terminal strip	427-2	2	Binding post base
462-19	1	Knob	438-14	2	Banana plug with alligator clip
			211-4	1	Handle
Wire			261-1	4	Rubber feet
89-1	1	Line cord	346-1	1	length Spaghetti (sleeving)
344-1	1	Roll hookup wire	595-99	1	Manual
340-2	1	length Bare wire			
Transformer-Meter					
54-34	1	Power transformer			
407-28	1	Meter			

SCHMATIC REPRESENTATION

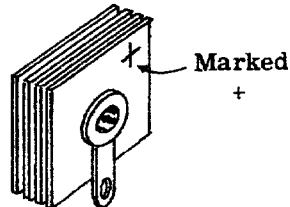
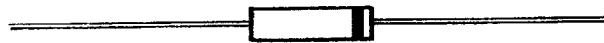
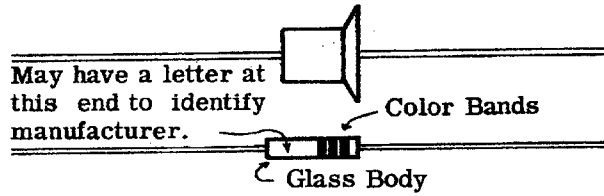
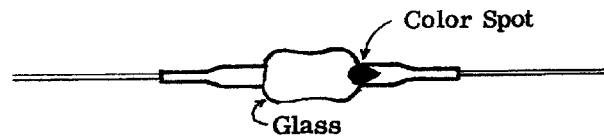
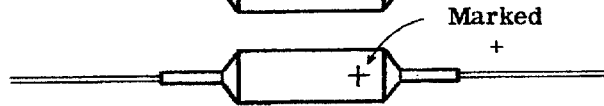
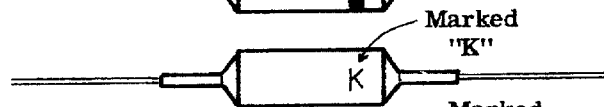
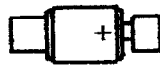
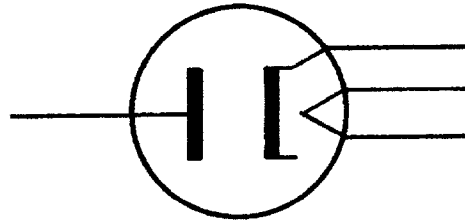

ANODES

CATHODES

TUBE, GERMANIUM, SILICON AND SELENIUM DIODES

HEATH COMPANY

A Subsidiary of Daystrom Inc.

THE WORLD'S FINEST ELECTRONIC EQUIPMENT IN KIT FORM

BENTON HARBOR, MICHIGAN

Copyright 1957
Heath Company
Benton Harbor, Michigan

Made in U.S.A.