

# HEATHKIT<sup>®</sup> MANUAL

for the

## ANTENNA TUNER

Model HFT-9

595-2948

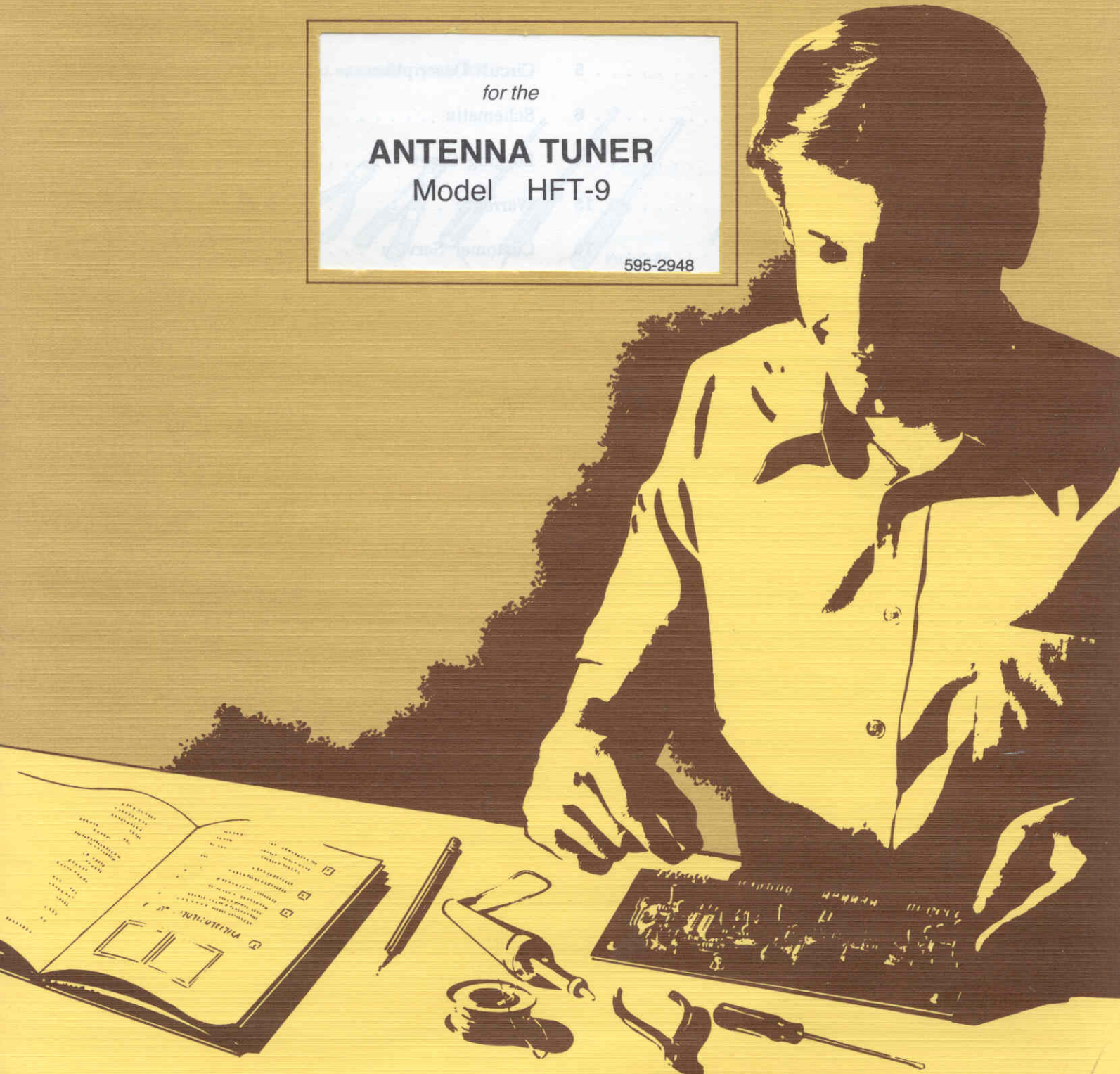

HEATH COMPANY • BENTON HARBOR, MICHIGAN

# HEATH COMPANY PHONE DIRECTORY

The following telephone numbers are direct lines to the departments listed:

Kit orders and delivery information ..... (616) 982-3411  
Credit ..... (616) 982-3561  
Replacement Parts ..... (616) 982-3571

## Technical Assistance Phone Numbers

8:00 A.M. to 12 P.M. and 1:00 P.M. to 4:30 P.M., EST, Weekdays Only  
R/C, Audio, and Electronic Organs ..... (616) 982-3310  
Amateur Radio ..... (616) 982-3296  
Test Equipment, Weather Instruments and  
Home Clocks ..... (616) 982-3315  
Television ..... (616) 982-3307  
Aircraft, Marine, Security, Scanners, Automotive,  
Appliances and General Products ..... (616) 982-3496  
Computers — Hardware ..... (616) 982-3309  
Computers — Software:  
Operating Systems, Languages, Utilities ..... (616) 982-3860  
Application Programs ..... (616) 982-3884  
Heath Craft Wood Works ..... (616) 982-3423



## YOUR HEATHKIT 90-DAY LIMITED WARRANTY

### Consumer Protection Plan for Heathkit Consumer Products

Welcome to the Heath family. We believe you will enjoy assembling your kit and will be pleased with its performance. Please read this Consumer Protection Plan carefully. It is a "LIMITED WARRANTY" as defined in the U.S. Consumer Product Warranty and Federal Trade Commission Improvement Act. This warranty gives you specific legal rights, and you may also have other rights which vary from state to state.

#### Heath's Responsibility

**PARTS** — Replacements for factory defective parts will be supplied free for 90 days from date of purchase. Replacement parts are warranted for the remaining portion of the original warranty period. You can obtain warranty parts direct from Heath Company by writing or telephoning us at (616) 982-3571. And we will pay shipping charges to get those parts to you . . . anywhere in the world.

**SERVICE LABOR** — For a period of 90 days from the date of purchase, any malfunction caused by defective parts or error in design will be corrected at no charge to you. You must deliver the unit at your expense to the Heath factory, any Heathkit Electronic Center (units of Veritechnology Electronics Corporation), or any of our authorized overseas distributors.

**TECHNICAL CONSULTATION** — You will receive free consultation on any problem you might encounter in the assembly or use of your Heathkit product. Just drop us a line or give us a call. Sorry, we cannot accept collect calls.

**NOT COVERED** — The correction of assembly errors, adjustments, calibration, and damage due to misuse, abuse, or negligence are not covered by the warranty. Use of corrosive solder and/or the unauthorized modification of the product or of any furnished component, will void this warranty in its entirety. This warranty does not include reimbursement for inconvenience, loss of use, customer assembly, set-up time, or unauthorized service.

This warranty covers only Heath products and is not extended to other equipment or components that a customer uses in conjunction with our products.

SUCH REPAIR AND REPLACEMENT SHALL BE THE SOLE REMEDY OF THE CUSTOMER AND THERE SHALL BE NO LIABILITY ON THE PART OF HEATH FOR ANY SPECIAL, INDIRECT, INCIDENTAL OR CONSEQUENTIAL DAMAGES, INCLUDING BUT NOT LIMITED TO ANY LOSS OF BUSINESS OR PROFITS, WHETHER OR NOT FORSEEABLE.

Some states do not allow the exclusion or limitation of incidental or consequential damages, so the above limitation or exclusion may not apply to you.

#### Owner's Responsibility

**EFFECTIVE WARRANTY DATE** — Warranty begins on the date of first consumer purchase. You must supply a copy of your proof of purchase when you request warranty service or parts.

**ASSEMBLY** — Before seeking warranty service, you should complete the assembly by carefully following the manual instructions. Heathkit service agencies cannot complete assembly and adjustments that are customer's responsibility.

**ACCESSORY EQUIPMENT** — Performance malfunctions involving other non-Heath accessory equipment, (antennas, audio components, computer peripherals and software, etc.) are not covered by this warranty and are the owner's responsibility.

**SHIPPING UNITS** — Follow the packing instructions published in the assembly manuals. Damage due to inadequate packing cannot be repaired under warranty.

If you are not satisfied with our service (warranty or otherwise) or our products, write directly to our Director of Customer Service, Heath Company, Benton Harbor MI 49022. He will make certain your problems receive immediate, personal attention.

TABLE OF CONTENTS

# Heathkit® Manual

for the

## ANTENNA TUNER

Model HFT-9

595-2948

### INTRODUCTION

one and impedance loads. A 1:1 balun is built in for use with balanced open wire lead lines. The small size, easy assembly, and lack of alignment make this Antenna Tuner a handy addition to any ham shack, emergency or old time alike.

The Heathkit Model HFT-9 Antenna Tuner is designed to be used with low-power (QRP) transmitters for 1.8 through 30 MHz (90-10 meters or 107-10 meters, user option). The Antenna Tuner will work with any transmitter that has up to 50 watts of output and will match the transmitter to various antennas.

TABLE OF CONTENTS

Introduction . . . . .	2	In Case of Difficulty . . . . .	17
Assembly Notes . . . . .	3	Specifications . . . . .	18
Parts List . . . . .	5	Circuit Description . . . . .	19
Step-By-Step Assembly . . . . .	6	Schematic . . . . .	19
Applications and Installation . . . . .	14	Logging Chart . . . . .	20
Operation . . . . .	15	Warranty . . . . .	Inside front cover
Typical Operating Characteristics . . . . .	16	Customer Service . . . . .	Inside rear cover

INTRODUCTION

The Heathkit Model HFT-9 Antenna Tuner is designed to be used with low-power (QRP) transmitters for 1.8 through 30 MHz (80-10 meters or 160-15 meters, user option). This Antenna Tuner will work with any transmitter that has up to 50 watts of output and will match the transmitter to various anten-

nas and impedance loads. A 4:1 balun is built-in for use with balanced open wire feed lines.

The small size, easy assembly, and lack of alignment make this Antenna Tuner a handy addition to any ham shack, newcomer or old timer alike.

## ASSEMBLY NOTES

### TOOLS

You will need these tools to assemble your kit.

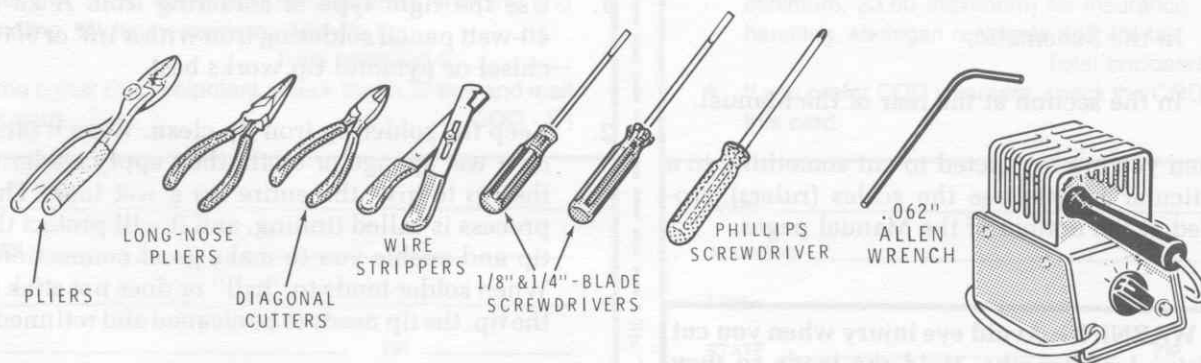

### OTHER HELPFUL TOOLS

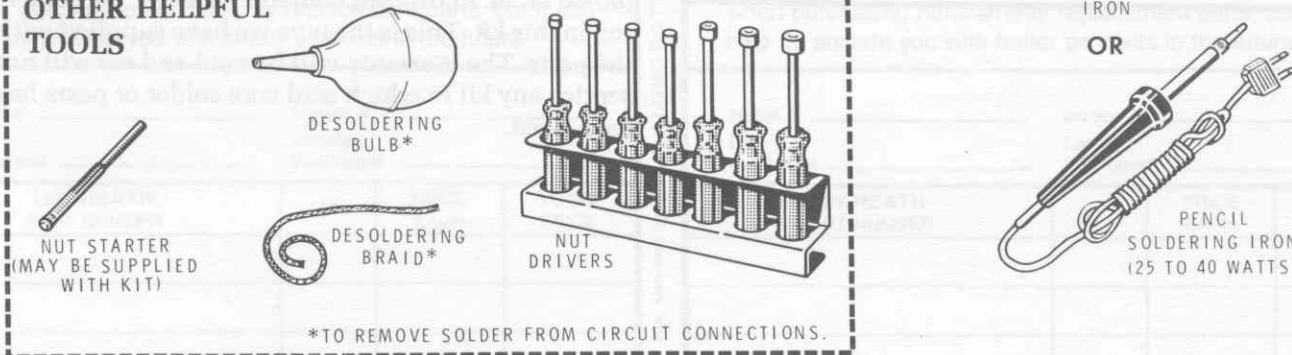

### ASSEMBLY

1. Follow the instructions carefully. Read the entire step before you perform each operation.
2. The illustrations in the Manual are called Pictorials and Details. Pictorials show the overall operation for a group of assembly steps; Details generally illustrate a single step. When you are directed to refer to a certain Pictorial "for the following steps," continue using that Pictorial until you are referred to another Pictorial for another group of steps.
3. Most kits use a separate "Illustration Booklet" that contains illustrations (Pictorials, Details, etc.) that are too large for the Assembly Manual. Keep the "Illustration Booklet" with the Assembly Manual. The illustrations in it are arranged in Pictorial number sequence.
4. Position all parts as shown in the Pictorials.
5. Solder a part or a group of parts only when you are instructed to do so.

6. Each circuit part in an electronic kit has its own component number (R2, C4, etc.). Use these numbers when you want to identify the same part in the various sections of the Manual. These numbers, which are especially useful if a part has to be replaced, appear:
- In the Parts List,
  - At the beginning of each step where a component is installed,
  - In some illustrations,
  - In the Schematic,
  - In the section at the rear of the Manual.
7. When you are instructed to cut something to a particular length, use the scales (rulers) provided at the bottom of the Manual pages.

**SAFETY WARNING: Avoid eye injury when you cut off excessive lead lengths. Hold the leads so they cannot fly toward your eyes.**

## SOLDERING

Soldering is one of the most important operations you will perform while assembling your kit. A good solder connection will form an electrical connection between two parts, such as a component lead and a circuit board foil. A bad solder connection could prevent an otherwise well-assembled kit from operating properly.

It is easy to make a good solder connection if you follow a few simple rules:

1. Use the right type of soldering iron. A 25 to 40-watt pencil soldering iron with a 1/8" or 3/16" chisel or pyramid tip works best.
2. Keep the soldering iron tip clean. Wipe it often on a wet sponge or cloth; then apply solder to the tip to give the entire tip a wet look. This process is called tinning, and it will protect the tip and enable you to make good connections. When solder tends to "ball" or does not stick to the tip, the tip needs to be cleaned and retinned.

NOTE: Always use rosin core, radio-type solder (60:40 or 50:50 tin-lead content) for all of the soldering in this kit. This is the type we have supplied with the parts. The Warranty will be void and we will not service any kit in which acid core solder or paste has been used.

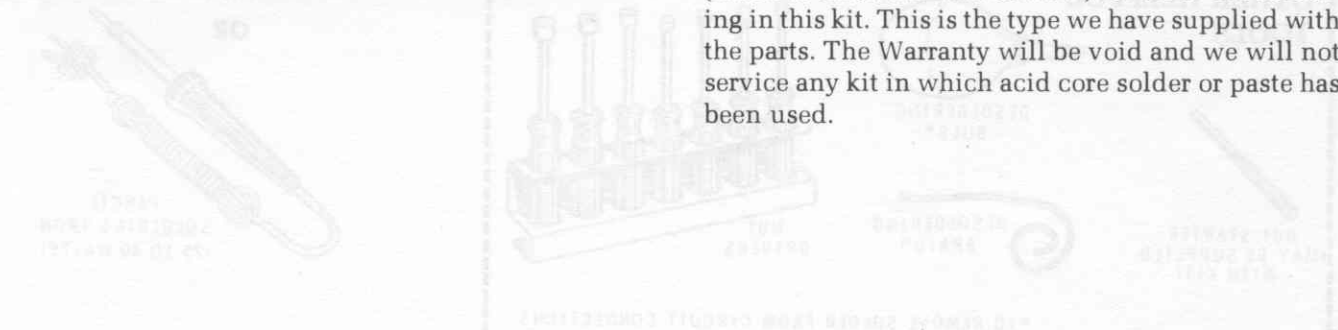

Assembly instructions are provided in the Manual. Read the instructions carefully. Read the instructions before you perform each operation.

The illustrations in the Manual are called "Illustration Details." The illustrations show the overall operation for a group of assembly steps. Details are generally illustrated in single steps. When you are directed to refer to a certain "Illustration" for the following step, you are referred to another "Illustration" for another group of steps.

Position all parts as shown in the Illustration.

Hold a part or a group of parts only when you are instructed to do so.

## PARTS LIST

Unpack the kit and check each part against the following list. The key numbers correspond to the numbers on the "Parts Pictorial" (Illustration Booklet, Page 1). Return any part that is packed in an individual envelope, with the part number on it, back into its envelope until that part is called for in a step. Do not throw away any packing material until you account for all of the parts.

To order a replacement part, always include the PART NUMBER. Use the Parts Order Form furnished with this kit. If a Parts Order Form is not available, refer to "Replacement Parts" inside the rear cover of this Manual. For prices, refer to the separate "Heath Parts Price List."

KEY No.	HEATH Part No.	QTY.	DESCRIPTION	CIRCUIT Comp. No.
---------	----------------	------	-------------	-------------------

## ELECTRONIC PARTS

A1	21-9	2	100 pF ceramic capacitor	C3, C4
A2	26-167	2	Variable capacitor	C1, C2
A3	40-2087	1	Inductor	L1
A4	63-1398	1	Rotary switch	SW1

## HARDWARE

NOTE: Hardware packets are marked to show the size of the hardware they contain (HDW#6, etc.). You may have to open more than one packet to locate all of the hardware of any one (#6, for example) size.

## #6 Hardware

B1	250-1282	2	6-32 × 1/8" setscrew
B2	250-230	1	6-32 × 3/16" setscrew
B3	250-1307	4	#6 × 1/4" sheet metal screw
B4	250-1429	4	6-32 × 3/8" screw
B5	250-1430	1	6-32 × 1/2" screw
B6	250-1240	1	6-32 × 7/8" screw
B7	252-3	6	6-32 nut
B8	252-66	1	6-32 wingnut
B9	253-96	2	#6 flat washer
B10	254-1	4	#6 lockwasher
B11	259-1	3	#6 solder lug

KEY No.	HEATH Part No.	QTY.	DESCRIPTION	CIRCUIT Comp. No.
---------	----------------	------	-------------	-------------------

## Other Hardware

C1	250-1410	4	4-40 × 1/4" flat head screw
C2	253-6	1	#10 fiber flat washer
C3	253-10	1	Control flat washer

## MISCELLANEOUS

D1	90-1293-1	1	Cabinet top	
D2	200-1428-1	1	Chassis	
D3	261-29	4	Foot	
	340-8	2	Small bare wire	
	340-9	18	Large bare wire	
	344-59	4	White wire	
D4	431-8	1	Terminal strip	
D5	436-51	2	Coaxial jack	J1, J2
D6	462-1151	1	Large knob	
D7	462-1152	2	Small knob	
D8	475-30	1	Ferrite core	
			Solder	

## PRINTED MATERIAL

E1	390-2412	1	Front panel label*
E2		1	Blue and white label*
	597-260	1	Parts Order Form*
		1	Assembly Manual (See Page 1 for the part number.)

\* These items may be packed inside the Manual.



## STEP-BY-STEP ASSEMBLY

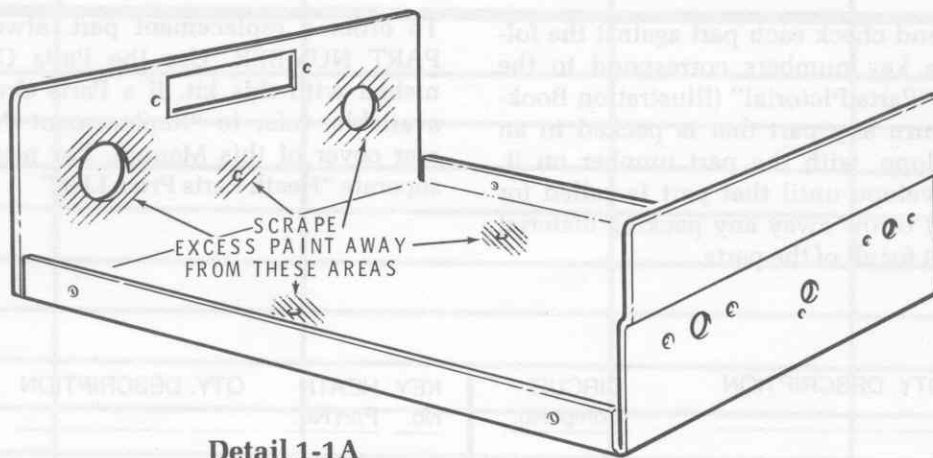

**Detail 1-1A**

Refer to Pictorial 1-1 (Illustration Booklet, Page 2) for the following steps.

- (✓) Refer to Detail 1-1A and use sandpaper or a knife to scrape any excess paint away from the areas shown. The hardware that you will mount at these locations require a good contact with the metal chassis.
- (✓) Carefully peel the backing paper from one of the feet. Then refer to Detail 1-1B and press the foot onto the bottom of the chassis near one corner as shown.
- (✓) Similarly, press feet onto the bottom of the chassis near the remaining three corners.

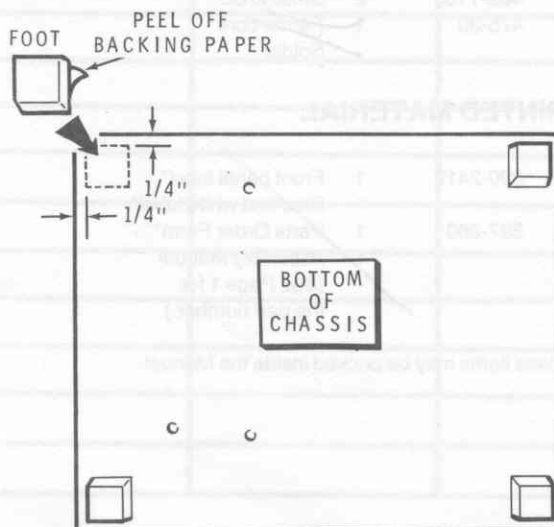

**Detail 1-1B**

- (✓) J1: Refer to Detail 1-1C and mount a coaxial jack onto the rear of the chassis at J1 as shown. Use the hardware supplied with the jack. Be sure to position the jack so the open side of the lug is upward as shown.
- (✓) J2: Similarly, mount a coaxial jack onto the rear of the chassis at J2. Use the hardware supplied with the jack and mount the jack so the open side of the lug is upward.

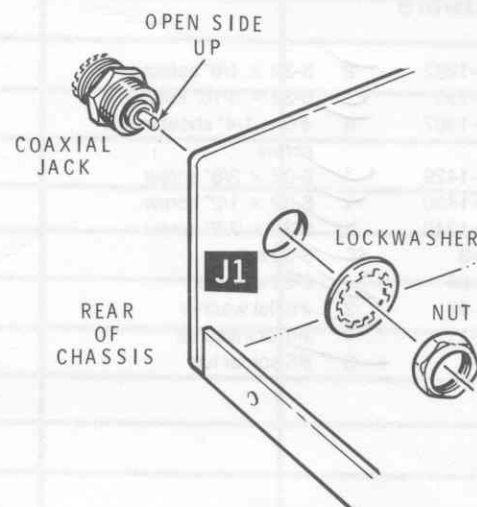

**Detail 1-1C**



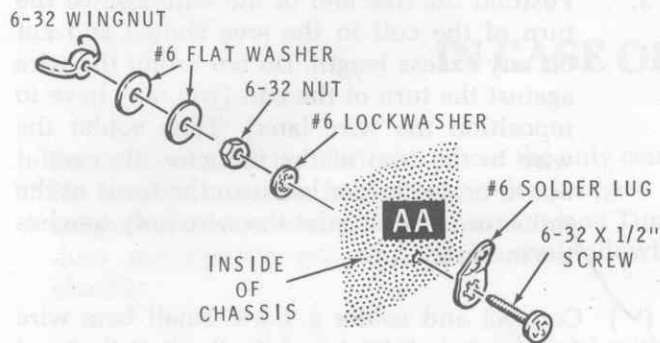

**Detail 1-1D**

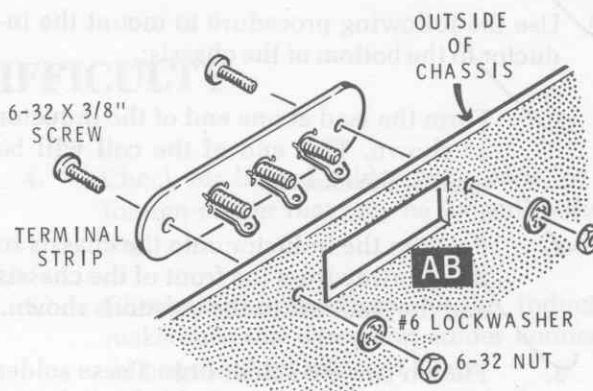

**Detail 1-1E**

Refer to Detail 1-1D and mount a #6 solder lug onto the rear of the chassis at AA as shown. Use a 6-32 x 1/2" screw, a #6 lockwasher, a 6-32 nut, two #6 flat washers, and a 6-32 wingnut. Be sure to position the solder lug as shown in the Pictorial.

Refer to Detail 1-1E and mount the terminal strip onto the rear of the chassis at AB. Use two 6-32 x 3/8" screws, two #6 lockwashers, and two 6-32 nuts. Be sure to mount the terminal strip on the **outside** of the chassis so the lugs are down as shown.

Refer to Detail 1-1F and use the following procedure to prepare the rotary switch:

1. Remove the hardware from the switch bushing. NOTE: To remove the metal ring, hold the switch with the shaft down; the metal ring will fall off of the bushing.
2. Break the tab off of the metal ring. The tab will not be used.

SW1: Refer to Detail 1-1G and temporarily mount the rotary switch onto the front of the chassis at SW1. Use the hardware supplied with the switch and a control flat washer to secure it. Be sure the locating tab on the switch enters its corresponding hole in the chassis. Tighten the hardware only finger tight at this time.

7  
708135  
2542  
-----  
68293

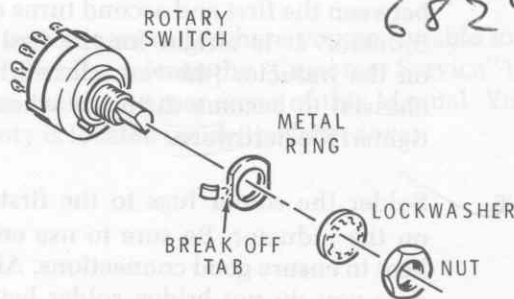

**Detail 1-1F**

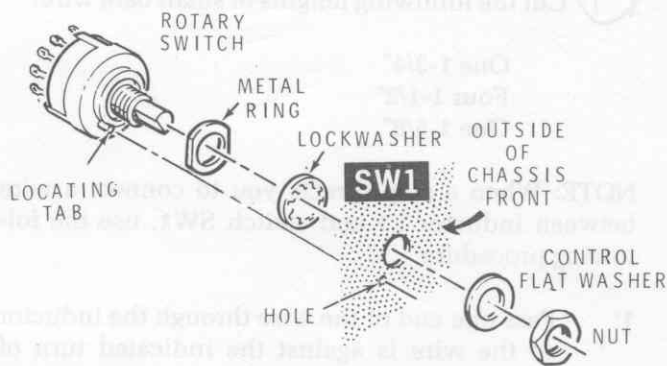

**Detail 1-1G**

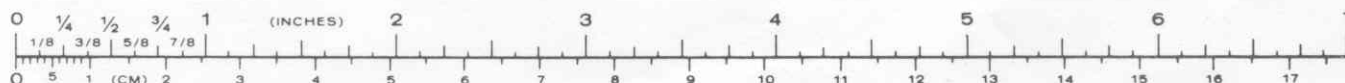

- (✓) Use the following procedure to mount the inductor to the bottom of the chassis:
1. Form the lead at one end of the inductor as shown. This end of the coil will be against the chassis.
  2. Position the inductor onto the chassis so it is 2" away from the front of the chassis and the leads are in the locations shown.
  3. Flatten two #6 solder lugs. These solder lugs will be used to hold the inductor in place.
  4. Use the two prepared #6 solder lugs, two 6-32 × 3/8" screws, and two 6-32 nuts to secure the inductor to the chassis. NOTE: Be sure the solder lugs are between the first and second turns of the inductor. It is alright for the first turn on the inductor (the turn closest to the chassis) to become distorted when you tighten the hardware.
  5. Solder the solder lugs to the first turn on the inductor. Be sure to use enough heat to ensure good connections. Also be sure you do not bridge solder between the first and second turns.
3. Position the free end of the wire against the turn of the coil in the area shown and cut off any excess length. Do not crimp the wire against the turn of the coil (you may have to reposition the wire later). Then solder the wire to the turn of the inductor. Be careful not to bridge solder between the turns of the inductor. Also be sure the wire only touches the indicated turn.
- (✓) Connect and solder a 1-3/4" small bare wire from switch SW1 lug A to the first (bottom) turn on inductor L1.
  - (✓) Connect and solder a 1-1/2" small bare wire from switch SW1 lug 11 to the third turn (from the bottom) on inductor L1.
  - (✓) Connect and solder a 1-1/2" small bare wire from switch SW1 lug 10 to the fifth turn on inductor L1.
  - (✓) Connect and solder a 1-1/2" small bare wire from switch SW1 lug 9 to the seventh turn on inductor L1.
  - (✓) Connect and solder a 1-1/2" small bare wire from switch SW1 lug 8 to the ninth turn on inductor L1.

Refer to Pictorial 1-2 (Illustration Booklet, Page 2) for the following steps.

- (✓) Cut the following lengths of small bare wire:

One 1-3/4"  
Four 1-1/2"  
One 1-5/8"

NOTE: When a step directs you to connect a wire between inductor L1 and switch SW1, use the following procedure:

1. Pass one end of the wire through the inductor so the wire is against the indicated turn of the inductor.
2. Connect the end of the wire to the indicated switch lug and solder it to the lug. NOTE: The lug numbers are stamped into the switch near the lugs.

- (✓) Cut the following lengths of small bare wire:

Three 1-5/8"  
One 1-3/4"  
One 2"  
One 2-1/4"

- (✓) Connect and solder a 1-5/8" small bare wire from switch SW1 lug 6 to the thirteenth turn on inductor L1.

NOTE: In the following steps, you will solder a wire to each remaining turn of the inductor. Do not skip every other turn, as you did in the above steps.

- (✓) Connect and solder a 1-5/8" small bare wire from switch SW1 lug 5 to the fourteenth turn on inductor L1.

# Heathkit®

- ✓ Connect and solder a 1-5/8" small bare wire from switch SW1 lug 4 to the fifteenth turn on inductor L1.
- ✓ Connect and solder a 1-3/4" small bare wire from switch SW1 lug 3 to the sixteenth turn on inductor L1.
- ✓ Connect and solder a 2" small bare wire from switch SW1 lug 2 to the seventeenth turn on inductor L1.
- ✓ Connect and solder a 2-1/4" small bare wire from switch SW1 lug 1 to the eighteenth turn on inductor L1.

Refer to Pictorial 1-3 (Illustration Booklet, Page 3) for the following steps.

- ✓ C1: Refer to Detail 1-3A and use the following procedure to mount a variable capacitor to the front of the chassis at C1:

1. Refer to Part A of the Detail and form the longer lug as shown. Be sure the lug cannot interfere with the operation of the variable capacitor.
2. Position the capacitor as shown in Part B of the Detail. Then use two 4-40 × 1/4" flat head screws to secure the capacitor to the chassis.

✓ C2: Similarly, mount the remaining variable capacitor to the front of the chassis at C2. Be sure to form the longer lug as you did in the above step before you mount the capacitor to the chassis.

- ✓ Set the chassis aside temporarily.

## PART A

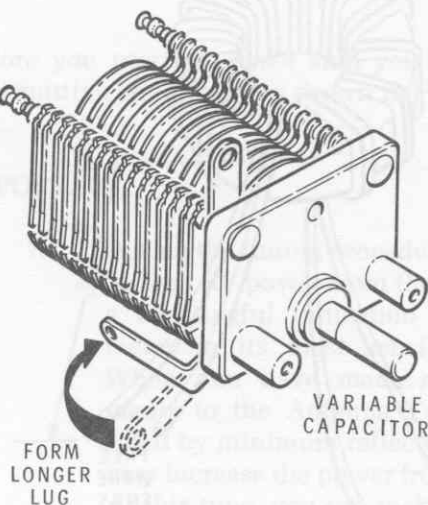

## PART B

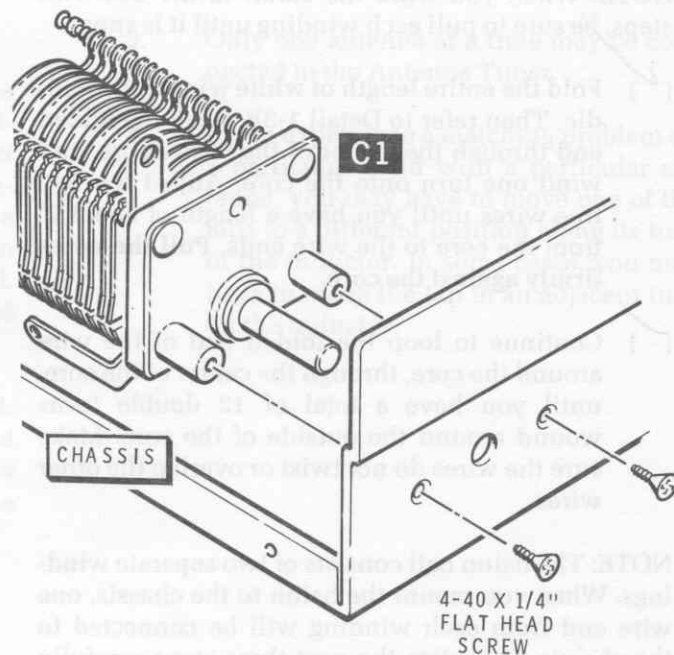

Detail 1-3A



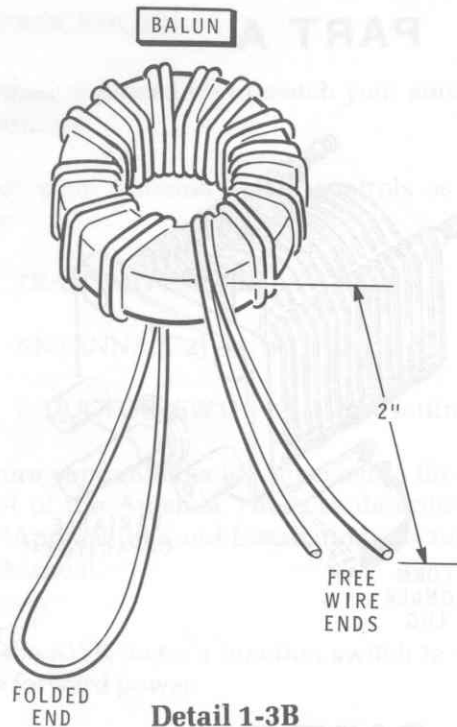

NOTE: When you wind the balun in the next two steps, be sure to pull each winding until it is snug.

- ( ) Fold the entire length of white wire in the middle. Then refer to Detail 1-3B, push the folded end through the center of the ferrite core, and wind one turn onto the core. Adjust the two free wires until you have a length of about 2" from the core to the wire ends. **Pull the wires firmly against the core.**
- ( ) Continue to loop the folded end of the wire around the core, through the center of the core, until you have a total of 12 double turns wound around the outside of the core. Make sure the wires do not twist or overlap the other wires.

NOTE: The balun coil consists of two separate windings. When you mount the balun to the chassis, one wire end from each winding will be connected to the chassis. Complete the next three steps carefully to make sure you select the proper wires.

- ( ) Position the balun as shown in Detail 1-3C (Illustration Booklet, Page 3) Part A (note the location of the looped end). Then remove 1/4" of insulation from the end of the indicated wire.

- ( ) Cut the looped end of the wire so it forms two separate wires. Then refer to Detail 1-3C Part B and remove insulation from the indicated wire. NOTE: If you have an ohmmeter, connect it between this wire and the other wire that has insulation removed. These two wires should **not** show continuity. If you do not have an ohmmeter, carefully compare your balun against Detail 1-3C Part B and make sure you have insulation removed from the correct wires.

- ( ) When you are sure you have the correct wires, shorten the longer one so it is the same length as the other wire that has insulation removed. Then again remove 1/4" of insulation from the end of the wire.

- ( ) Twist together (approximately 3 turns per inch) the two wires that have insulation removed.

- ( ) Refer to Detail 1-3C Part C and cut the remaining two wires coming from the balun to the lengths shown. Then remove 1/4" of insulation from the ends of these wires.

- ( ) T1: Refer to Detail 1-3D and mount the balun to the chassis at T1 as shown. Use a 6-32 x 7/8" screw, a #10 fiber flat washer, a #6 lockwasher, and a 6-32 nut. Be sure the wires are toward terminal strip AB and the longer wire comes from under the balun. Tighten the hardware only until it is snug.

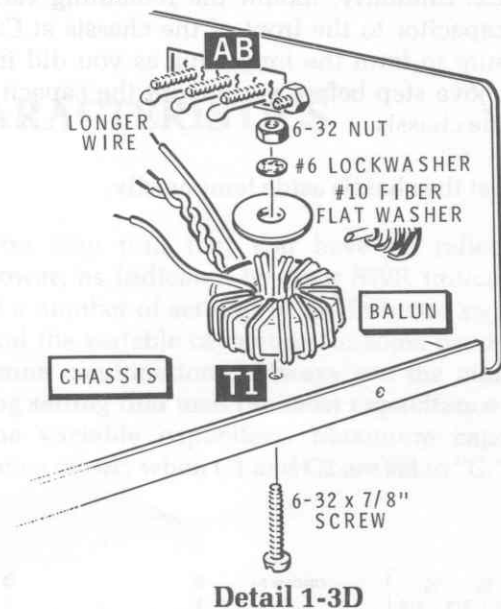

# Heathkit®

Refer to Pictorial 1-4 (Illustration Booklet, Page 4) for the following steps.

NOTE: In the following steps, (NS) means not to solder the connection because you will add other wires later. "S-" with a number, such as (S-2), means to solder the connection. The number following the "S-" tells you how many wires should be at the connection. This helps you check your work for errors as you go.

Connect the wires coming from balun coil T1 as follows:

- (✓) Bottom wire to terminal strip AB lug 1 (S-1).
- (✓) Twisted wires to solder lug AA (S-2).
- (✓) Top wire to terminal strip AB lug 2 (S-1).
- (✓) Carefully pull the wire coming from the top of inductor L1 out of insulator A. Be careful not to pull the wire out of insulator B. Then cut the wire so it extends 1" from insulator B.
- (✓) Connect the wire coming from insulator B of inductor L1 to variable capacitor C1 lug 4 (S-1).

- (✓) Cut the following lengths of large bare wire:

One 5"  
 One 3-3/4"  
 One 5-1/4"  
 One 1-3/4"

- (✓) Connect a 5" large bare wire from the lug of coaxial jack J1 (S-1) to variable capacitor C1 lug 1 (S-1).
- (✓) Connect a 3-3/4" large bare wire from variable capacitor C1 lug 2 (S-1) to variable capacitor C2 lug 2 (S-1).

- (✓) Connect a 5-1/4" large bare wire from variable capacitor C2 lug 1 (S-1) to the lug of coaxial jack J2 (NS). Do not let this wire touch the turns on the inductor or interfere with the operation of the variable capacitor.

- (✓) Connect a 1-3/4" large bare wire from terminal strip AB lug 3 (S-1) to the lug of coaxial jack J2 (S-2).

NOTE: Install the next two capacitors **only** if you intend to use your Antenna Tuner on 160 meters. If you do not intend to use the Antenna Tuner on 160 meters, do not install these capacitors; to do so could cause loading problems on 10 meters.

- ( ) C3: Cut the leads of a 100 pF ceramic capacitor to 1/2". Then connect the capacitor from variable capacitor C1 lug 3 (S-1) to the large bare wire going to coaxial jack J1 (S-1). Be sure this capacitor cannot interfere with the operation of variable capacitor C1.

- ( ) C4: Cut the leads of the remaining 100 pF ceramic capacitor to 3/4". Then connect the capacitor from variable capacitor C2 lug 4 (S-1) to the large bare wire going to coaxial jack J2 (S-1). Be sure this capacitor cannot interfere with the operation of variable capacitor C2.

NOTE: Carefully inspect the chassis for the following undesirable conditions:

1. Unsoldered connections.
2. Poor solder connections.
3. Bits of wire or solder that may be lodged in the wiring.
4. Leads that could short to the chassis, to other wires, or to lugs to which they are not connected. Pay particular attention to the wires connected to the inductor.

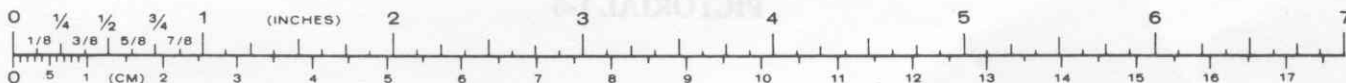

Refer to Pictorial 1-5 for the following steps.

- (✓) Position the chassis assembly as shown in the Pictorial.
- (✓) Temporarily remove the hardware from switch SW1 and set the hardware aside. You will use it to remount the switch later.
- (✓) Carefully peel the backing paper from the front panel label. Then line up the holes in the label with the shafts of variable capacitors C1 and

C2 and switch SW1, and press the label onto the front of the chassis.

- (✓) Use the hardware you removed earlier to secure switch SW1 to the chassis. Do not over-tighten the hardware.
- (✓) Turn the shaft of switch SW1 to its fully clockwise position.
- (✓) Refer to the inset drawing on the Pictorial and turn the shafts of variable capacitors C1 and C2 so their plates are half meshed.

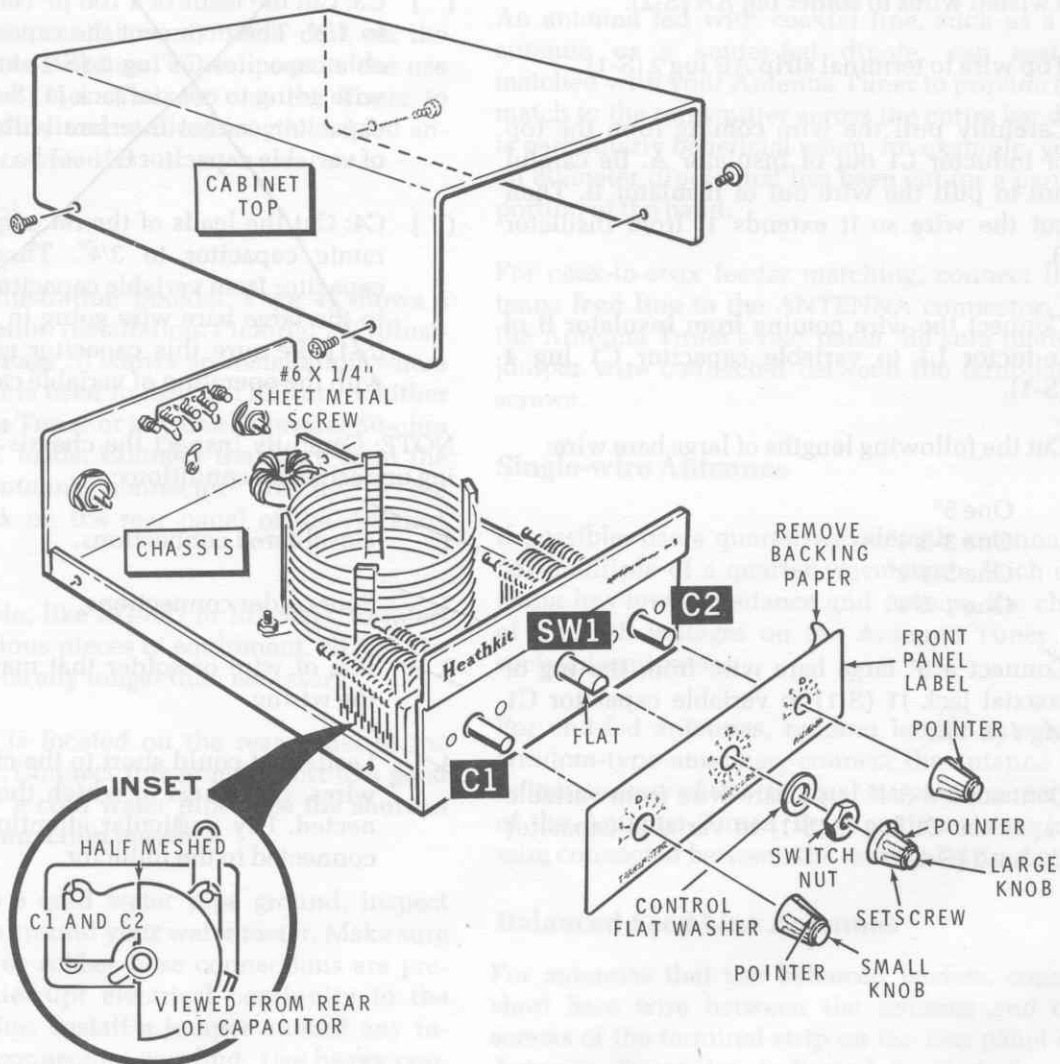

PICTORIAL 1-5

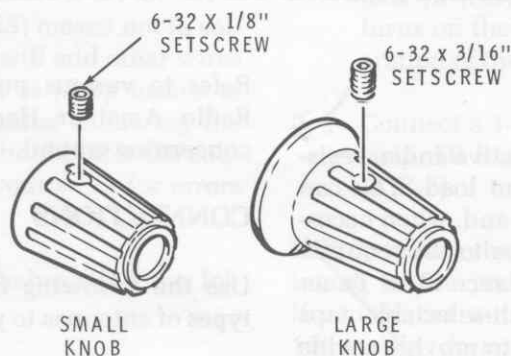

Detail 1-5A

- ✓ Refer to Detail 1-5A and start a 6-32 × 1/8" setscrew into each of the small knobs.
- ✓ Similarly, start a 6-32 × 3/16" setscrew into the large knob.
- ✓ Push the large knob onto the shaft of switch SW1. Then line up the knob pointer with the "12" on the front panel label and tighten the setscrew (against the flat on the shaft).
- ✓ Push a small knob onto the shaft of variable capacitor C1. Then line up the knob pointer with the "D" on the front panel label and tighten the setscrew.
- ✓ Similarly, install a small knob onto the shaft of variable capacitor C2. Be sure to line up the knob pointer with the "D" on the front panel label before you tighten the setscrew.

- ✓ Slide the cabinet top onto the chassis. Then secure the cabinet top to the chassis with four #6 × 1/4" sheet metal screws.
- ✓ Turn the chassis over so it is bottom-side-up. Then carefully peel the backing paper from the blue and white label, and press the label onto the bottom of the chassis. Be sure to refer to the numbers on this label in any communications you may have with the Heath Company about your kit.

This completes the assembly of your Antenna Tuner. Proceed to "Applications and Installation."

## APPLICATIONS AND INSTALLATION

### APPLICATIONS

This Antenna Tuner converts a reactive and/or resistive load to a nonreactive, 50-ohm load. You can adjust it to tune out load reactance and, when necessary, transform the load impedance to the required 50-ohm transmitter output impedance. The Tuner uses an inductor that has switch-selectable taps along with two variable capacitors to provide a wide matching range, and features 80-meter through 10-meter, or 160-meter through 15-meter, coverage.

A 4:1 (balanced-to-unbalanced) balun coil, on the output side of the Antenna Tuner, permits the use of balanced feed lines. You can use the Tuner to match into coaxial lines, random-length end-fed antennas, or balanced feeders.

### INSTALLATION

Pictorial 2-1 (Illustration Booklet, Page 4) shows a typical fixed-station installation. Pictorial 2-2 (Illustration Booklet, Page 5) shows an installation where a coaxial switch is used to feed the RF source either to your Antenna Tuner or any one of several 50-ohm antennas or RF loads. Connect the cable from the transmitter's antenna connector directly to the Transmitter jack on the rear panel of the Antenna Tuner.

Use coaxial cable, like RG-8/U or RG-58/U, to interconnect the various pieces of equipment. NOTE: Cables should not be any longer than necessary.

A ground post is located on the rear panel of the Antenna Tuner. Connect this ground post to a good earth ground or a cold water pipe. **Use the shortest and heaviest connection possible.**

Before you use a cold water pipe ground, inspect the connections around your water meter. Make sure that no plastic or rubber hose connections are present, which interrupt electrical continuity to the water supply line. Install a jumper around any insulating water connectors you find. Use heavy copper wire and pipe clamps. It is best to ground all equipment to one point at the operating position; and then ground this point as described above.

Refer to various publications, such as the ARRL Radio Amateur Handbook, for more information concerning ground.

### CONNECTIONS

Use the following information to connect various types of antennas to your Antenna Tuner.

#### Coaxial-fed Antennas

An antenna fed with coaxial line, such as a beam antenna or a center-fed dipole, can easily be matched with your Antenna Tuner to provide a good match to the transmitter across the entire band. This is particularly beneficial when, for example, you use an 80-meter dipole that has been cut for a particular portion of the band.

For coax-to-coax feeder matching, connect the antenna feed line to the ANTENNA connector, J2, on the Antenna Tuner's rear panel. Be sure there is no jumper wire connected between the terminal strip screws.

#### Single-wire Antennas

If possible, use a quarter-wavelength antenna or an odd multiple of a quarter wavelength. Such an antenna has low impedance and reduces the chances of high RF voltages on the Antenna Tuner or associated equipment.

For end-fed antennas, random length antennas, or windom-type antennas, connect the antenna to the leftmost screw of the terminal strip on the rear panel of the Antenna Tuner. Be sure there is no jumper wire connected between the terminal strip screws.

#### Balanced Feed Line Antennas

For antennas that use balanced feeders, connect a short bare wire between the leftmost and center screws of the terminal strip on the rear panel of the Antenna Tuner (as indicated by "wire" on the panel). Connect the antenna feedline between the center and rightmost screws of the terminal strip on the rear panel of the Antenna Tuner.



## OPERATION

Refer to Pictorial 3-1 (Illustration Booklet, Page 6) to identify the front panel controls. A description of the function of each is included. Refer to Pictorial 3-2 (Illustration Booklet, Page 6) for the rear panel connections.

### EXCITER TUNE-UP

The final stage of some transmitters must be tuned up before they can be placed on the air. It is important that you tune up an exciter on a "dummy load" **before** you use it with your Antenna Tuner. You can use any load that has a constant, resistive impedance of 50 ohms and can dissipate the necessary power for a reasonable length of time. As an example, the Heathkit "Cantenna" is a satisfactory load. **NOTE:** Do **NOT** use light bulbs as a "dummy load." Their resistances vary with the current, and their reactances vary with frequency.

### COUPLER TUNING

This part of the "Operation" section includes the procedure for using your Antenna Tuner with various antenna systems. After you determine the proper settings of the controls for a particular band and antenna, be sure to record the settings of both variable capacitor knobs and the switch position so you can preset the controls the next time you use the band. For your convenience, a "Logging Chart" is included on Page 20 of this Manual.

**NOTE:** The "ARRL Antenna Book" is readily available and includes comprehensive information about transmission lines and antennas. You can purchase other similar radio amateur handbooks, and some are available in public libraries.

Before you proceed, make sure you connect your transmitting equipment as shown in Pictorial 2-1 or 2-2.

### IMPORTANT:

1. During the tuning procedure, apply only enough RF power from the exciter to get a meaningful indication on the SWR meter in its most sensitive position. When you have made coarse adjustments to the Antenna Tuner, as indicated by minimum reflected power, you may increase the power from the exciter. At this time, you can make final adjustments to the Antenna Tuner.
2. When you tune your exciter, be **SURE** to observe the duty cycle limitations, if there are any.
3. Only one antenna at a time may be connected to the Antenna Tuner.
4. If you experience a matching problem on a particular band with a particular antenna, you may have to move one of the taps to a different position along its turn of the inductor. In some cases, you may have to move the tap to an adjacent turn on the inductor.

## TUNING PROCEDURE

Use the following procedure to match your antenna to your transmitter:

1. Preset your Antenna Tuner controls as follows:

TRANSMITTER (C1)	D
ANTENNA (C2)	D
INDUCTOR (SW1)	Any setting

2. Be sure your antenna is connected to the rear panel of the Antenna Tuner as described in the "Applications and Installation" section of this Manual.
3. Set the SWR meter's function switch to measure forward power.
4. Set the sensitivity control of the SWR meter to the most sensitive position.
5. Turn the exciter power on.
6. Adjust INDUCTOR switch SW1 for maximum noise (in the receive mode).
7. With the exciter in either the tune or CW mode, advance the exciter's gain for a meaningful indication on the SWR meter.

8. Set the function switch of the SWR meter to read reflected power. Then adjust INDUCTOR switch SW1 for minimum reflected power.
9. Adjust TRANSMITTER capacitor C1 until you obtain the lowest SWR indication.
10. Adjust ANTENNA capacitor C2 until you obtain the lowest SWR indication.

### NOTES:

- A. Since capacitors C1 and C2 interact, repeat steps 9 and 10 until you obtain minimum SWR. If you cannot obtain minimum SWR at this INDUCTOR setting, increase or decrease the INDUCTOR setting one position and then repeat steps 9 and 10.
  - B. With many antenna systems, you can obtain several different matching combinations. **Always use the matching setting that uses the most capacitance for C1 and C2, as maximum capacitance provides best harmonic attenuation.** Maximum capacitance occurs when C1 and C2 are set to "G."
11. When you obtain minimum SWR, you can increase the transmitter for full power output (maximum 50 watts).

This completes the "Tuning Procedure."

## TYPICAL OPERATING CHARACTERISTICS

- A severe mismatch may cause a transmitter to become unstable until the SWR is reduced to a low value (1.5:1 or less). This is especially true of broadband solid-state transmitters. However, this can also occur with tube-type transmitters.
- You may find that you have no reflected power, as indicated by your SWR indicator, at a number of settings of the Inductor switch and the variable capacitors for some band/antenna combinations. **Always use the matching setting that uses the most capacitance for the variable capacitors.** Maximum capacitance occurs when C1 and C2 are set to "G."

## IN CASE OF DIFFICULTY

Due to the simplicity of this kit, about the only cause for trouble is errors in wiring, solder bridges, or wires shorted to metal parts. If your Antenna Tuner does not operate properly, make the following checks:

1. Recheck the wiring. Trace each lead with a colored pencil on the Pictorial as you check it. It is frequently helpful to have a friend check your work. Someone who is not familiar with the unit may notice something that you have consistently overlooked.
2. About 90% of the kits that are returned to the Heath Company for service do not function properly due to poor connections and soldering. Therefore, you can eliminate many troubles by reheating all of the connections to make sure they are well soldered.
3. Be sure all of the wires and leads have been trimmed as close as possible to their connection points.
4. Check for bits of solder, wire ends, or other foreign matter that may be lodged in the wiring.
5. Check the connections to the inductor to make sure the wires and solder connections do not short out adjacent turns.
6. The antenna feedlines you use should be insulated along their entire length to prevent any contact with any parts of buildings, trees, etc. For maximum operating efficiency, keep the antenna as far as possible from other objects that could affect its operation.

In an extreme case where you are unable to resolve a difficulty, refer to the "Customer Service" information inside the rear cover of this Manual. Your Warranty is located inside the front cover.



## SPECIFICATIONS

Frequency Range . . . . .	80 through 10 meters or 160 through 15 meters, user option.
Power Capability . . . . .	50 watts.
Input Impedance . . . . .	50 ohms.
Output Impedance . . . . .	Wide Range.
Impedance Transformation . . . . .	4:1 balun for balanced lines.
Dimensions (overall) . . . . .	5-1/2" wide × 2-5/8" high × 7-1/2" deep. (13.6 × 7.3 × 17.8 cm)
Net Weight . . . . .	1.5 lbs. (0.7 kg).

The Heath Company reserves the right to discontinue products and to change specifications at any time without incurring any obligation to incorporate new features in products previously sold.

Refer to Pictorial 1-2 (Illustrated Booklet, Page 2) for the following steps:

1. Cut the following lengths of small bare wire:

- One 1-3/4"
- Four 1-1/2"
- One 1-1/8"

NOTE: When a step directs you to connect a wire between indicator LI and switch SW1, use the following procedure:

1. Push one end of the wire through the indicator so the wire is against the indicated part of the indicator.
2. Connect the end of the wire to the indicated switch lug and solder it to the lug. NOTE: The lug numbers are stamped into the switch case the top.

2. Connect and solder a 1-3/4" small bare wire from switch SW1 lug 1 to the indicator LI.

3. Cut the following lengths of small bare wire:

- Three 1-3/4"
- One 1-3/8"
- One 1"
- One 1-1/4"

4. Connect and solder a 1-3/8" small bare wire from switch SW1 lug 2 to the indicator LI.

NOTE: In the following steps, you will solder a wire to each mounting post of the indicator. Do not skip any of these steps or you will not be able to use the indicator.

5. Connect and solder a 1-3/4" small bare wire from switch SW1 lug 3 to the indicator LI.

## CIRCUIT DESCRIPTION

Refer to the Schematic Diagram while you read this "Circuit Description."

The Antenna Tuner is an adjustable RF transformer that matches an unknown load, presented by an antenna and its feedline, to the required 50-ohm transmitter impedance.

Coupling capacitor C2 matches the load impedance fed back to the tuned circuit formed by capacitor C1 and inductor L1. The total resonant impedance across the tuned circuit depends upon the L/C ratio of C1 and L1, and the load impedance as transformed by C2. Capacitor C1 performs capacitive tap-

ping and results in a 50-ohm impedance at Transmitter input connector J1.

Capacitors C3 and C4 extend the frequency range down to 1.8 MHz. These capacitors should not be installed unless you use the Antenna Tuner on the 160-meter band and cannot obtain the proper results without them. Installation of these capacitors may restrict the upper end of the frequency range to something less than 30 MHz.

A 4:1 balun coil, T1, is provided so you can use the Antenna Tuner with balanced lines.

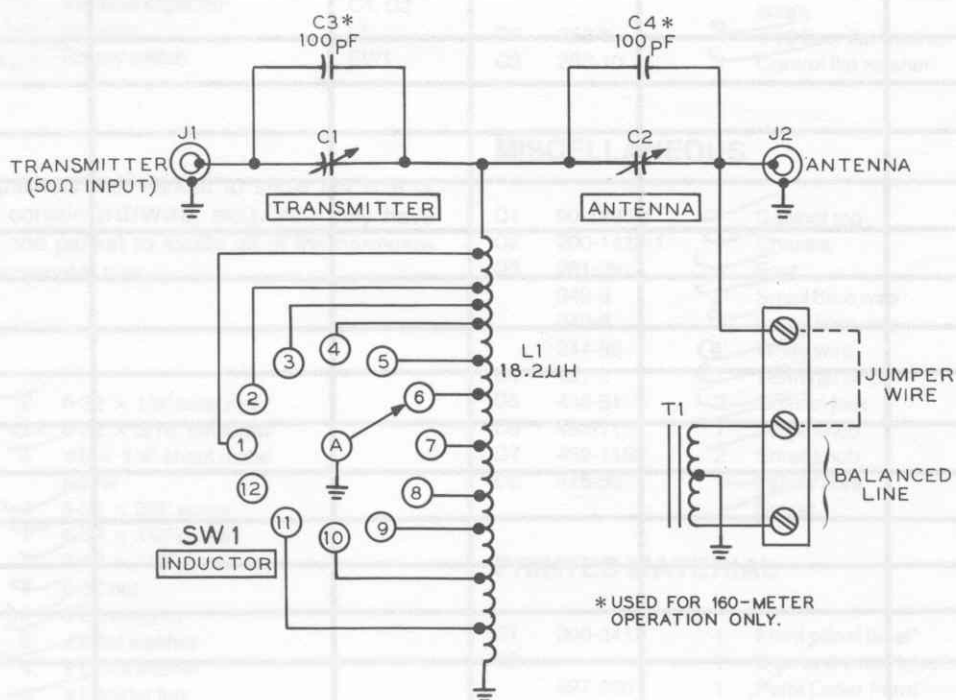

**Schematic of the  
Heathkit®  
Antenna Tuner  
Model HFT-9**



**FOR PARTS REQUESTS ONLY**

- Be sure to follow instructions carefully.
- Use a separate letter for all correspondence.
- Please allow 10 - 14 days for mail delivery time.

**DO NOT WRITE IN THIS SPACE**

**INSTRUCTIONS**

- Please print all information requested.
- Be sure you list the correct **HEATH** part number exactly as it appears in the parts list.
- If you wish to prepay your order, mail this card and your payment in an envelope. Be sure to include 10% (25¢ minimum, \$3.50 maximum) for insurance, shipping and handling. Michigan residents add 4% tax.  
Total enclosed \$ \_\_\_\_\_
- If you prefer COD shipment, check the COD box and mail this card. COD

NAME \_\_\_\_\_  
 ADDRESS \_\_\_\_\_  
 CITY \_\_\_\_\_  
 STATE \_\_\_\_\_ ZIP \_\_\_\_\_

The information requested in the next two lines is not required when purchasing nonwarranty replacement parts, but it can help us provide you with better products in the future.

Model # \_\_\_\_\_ Invoice # \_\_\_\_\_  
 Date Purchased \_\_\_\_\_ Location Purchased \_\_\_\_\_

LIST HEATH PART NUMBER	QTY.	PRICE EACH	TOTAL PRICE

TOTAL FOR PARTS	
HANDLING AND SHIPPING	
MICHIGAN RESIDENTS ADD 4% TAX	
<b>TOTAL AMOUNT OF ORDER</b>	

SEND TO: **HEATH COMPANY**  
 BENTON HARBOR  
 MICHIGAN 49022  
**ATTN: PARTS REPLACEMENT**

Phone (Replacement parts only): 616 982-3571

**FOR PARTS REQUESTS ONLY**

- Be sure to follow instructions carefully.
- Use a separate letter for all correspondence.
- Please allow 10 - 14 days for mail delivery time.

**DO NOT WRITE IN THIS SPACE**

**INSTRUCTIONS**

- Please print all information requested.
- Be sure you list the correct **HEATH** part number exactly as it appears in the parts list.
- If you wish to prepay your order, mail this card and your payment in an envelope. Be sure to include 10% (25¢ minimum, \$3.50 maximum) for insurance, shipping and handling. Michigan residents add 4% tax.  
Total enclosed \$ \_\_\_\_\_
- If you prefer COD shipment, check the COD box and mail this card. COD

NAME \_\_\_\_\_  
 ADDRESS \_\_\_\_\_  
 CITY \_\_\_\_\_  
 STATE \_\_\_\_\_ ZIP \_\_\_\_\_

The information requested in the next two lines is not required when purchasing nonwarranty replacement parts, but it can help us provide you with better products in the future.

Model # \_\_\_\_\_ Invoice # \_\_\_\_\_  
 Date Purchased \_\_\_\_\_ Location Purchased \_\_\_\_\_

LIST HEATH PART NUMBER	QTY.	PRICE EACH	TOTAL PRICE

TOTAL FOR PARTS	
HANDLING AND SHIPPING	
MICHIGAN RESIDENTS ADD 4% TAX	
<b>TOTAL AMOUNT OF ORDER</b>	

SEND TO: **HEATH COMPANY**  
 BENTON HARBOR  
 MICHIGAN 49022  
**ATTN: PARTS REPLACEMENT**

Phone (Replacement parts only): 616 982-3571

CUT ALONG DOTTED LINE

# CUSTOMER SERVICE

## REPLACEMENT PARTS

Please provide complete information when you request replacements from either the factory or Heath Electronic Centers. Be certain to include the **HEATH** part number exactly as it appears in the parts list.

## ORDERING FROM THE FACTORY

Print all of the information requested on the parts order form furnished with this product and mail it to Heath. For telephone orders (parts only) dial 616 982-3571. If you are unable to locate an order form, write us a letter or card including:

- Heath part number.
- Model number.
- Date of purchase.
- Location purchased or invoice number.
- Nature of the defect.
- Your payment or authorization for COD shipment of parts not covered by warranty.

Mail letters to: Heath Company  
Benton Harbor  
MI 49022  
Attn: Parts Replacement

**Retain original parts until you receive replacements. Parts that should be returned to the factory will be listed on your packing slip.**

## OBTAINING REPLACEMENTS FROM HEATH ELECTRONIC CENTERS

For your convenience, "over the counter" replacement parts are available from the Heath Electronic Centers listed in your catalog. Be sure to bring in the original part and purchase invoice when you request a warranty replacement from a Heath Electronic Center.

## TECHNICAL CONSULTATION

Need help with your kit? — Self-Service? — Construction? — Operation? — Call or write for assistance. you'll find our Technical Consultants eager to help with just about any technical problem except "customizing" for unique applications.

The effectiveness of our consultation service depends on the information you furnish. Be sure to tell us:

- The Model number and Series number from the blue and white label.
- The date of purchase.
- An exact description of the difficulty.
- Everything you have done in attempting to correct the problem.

Also include switch positions, connections to other units, operating procedures, voltage readings, and any other information you think might be helpful.

**Please do not send parts for testing**, unless this is specifically requested by our Consultants.

Hints: Telephone traffic is lightest at midweek — please be sure your Manual and notes are on hand when you call.

Heathkit Electronic Center facilities are also available for telephone or "walk-in" personal assistance.

## REPAIR SERVICE

Service facilities are available, if they are needed, to repair your completed kit. (Kits that have been modified, soldered with paste flux or acid core solder, cannot be accepted for repair.)

**If it is convenient, personally deliver your kit to a Heathkit Electronic Center. For warranty parts replacement, supply a copy of the invoice or sales slip.**

If you prefer to ship your kit to the factory, attach a letter containing the following information directly to the unit:

- Your name and address.
- Date of purchase and invoice number.
- Copies of all correspondence relevant to the service of the kit.
- A brief description of the difficulty.
- Authorization to return your kit COD for the service and shipping charges. (This will reduce the possibility of delay.)

Check the equipment to see that all screws and parts are secured. (Do not include any wooden cabinets or color television picture tubes, as these are easily damaged in shipment. Do not include the kit Manual.) Place the equipment in a strong carton with at least **THREE INCHES** of *resilient* packing material (shredded paper, excelsior, etc.) on all sides. Use additional packing material where there are protrusions (control sticks, large knobs, etc.). If the unit weighs over 15 lbs., place this carton in another one with 3/4" of packing material between the two.

Seal the carton with reinforced gummed tape, tie it with a strong cord, and mark it "Fragile" on at least two sides. Remember, the carrier will not accept liability for shipping damage if the unit is insufficiently packed. Ship by prepaid express, United Parcel Service, or insured Parcel Post to:

Heath Company  
Service Department  
Benton Harbor, Michigan 49022





**HEATH COMPANY • BENTON HARBOR, MICHIGAN**  
***THE WORLD'S FINEST ELECTRONIC EQUIPMENT IN KIT FORM***

LITHO IN U.S.A.