

**Instruction Manual  
Model 619  
Electrometer/Multimeter**

**©1981, Keithley Instruments, Inc.  
Cleveland, Ohio, U.S.A.**

# SPECIFICATIONS

## VOLTS

RANGE	MAXIMUM READING	ACCURACY	TEMPERATURE COEFFICIENT
		1 YR., 23° ± 5°C ± (%rdg + counts)	0-18°C & 28-50°C ± (%rdg + counts)/°C
200mV	199,999 × 10 <sup>-3</sup>	0.01 % + 25	0.002% + 30
2 V	1.99999	0.01 % + 10	0.002% + 3
20 V	19.9999	0.02% + 10	0.002% + 0.3
200 V	199.999	0.02% + 10	0.002% + 0.3

**INPUT CAPACITANCE:** Less than or equal to 20pF.

**INPUT RESISTANCE:** Greater than or equal to 20TΩ.

**NMRR:** Greater than 55dB (greater than 80dB with FILTER).

**CMRR:** Greater than 100dB (greater than 125dB with FILTER).

**ANALOG SETTling TIME (to 0.1% of final value, unfiltered):** Less than 5ms.

## AMPS

RANGE	MAXIMUM READING	ACCURACY	TEMPERATURE COEFFICIENT	INVERTING FULL SCALE ANALOG OUTPUT
		1 YR., 23° ± 5°C ± (%rdg + counts)	0-18°C & 28-50°C ± (%rdg + counts)/°C	
2 nA	1.99999 × 10 <sup>-9</sup>	0.35% + 65	0.02% + 30	0.2V
20 nA	19.9999 × 10 <sup>-9</sup>	0.35% + 35	0.02% + 3	2.0V
200 nA	199.999 × 10 <sup>-9</sup>	0.15% + 25	0.01% + 30	0.2V
2 μA	1.99999 × 10 <sup>-6</sup>	0.15% + 10	0.01% + 3	2.0V
20 μA	19.9999 × 10 <sup>-6</sup>	0.15% + 25	0.01% + 30	0.2V
200 μA	199.999 × 10 <sup>-6</sup>	0.15% + 10	0.01% + 3	2.0V
2mA	1.99999 × 10 <sup>-3</sup>	0.15% + 25	0.01% + 30	0.2V
20mA	19.9999 × 10 <sup>-3</sup>	0.15% + 10	0.01% + 3	2.0V
2 A	1.99999	0.15% + 25	0.01% + 20	None

**INPUT VOLTAGE DROP:** Less than 1mV at full-scale except less than 0.6V on 2A range.

**ANALOG SETTling TIME (to 0.1% of final value, unfiltered):** 2nA through 2μA: 50ms; 20μA through 2A: 5ms.

**NMRR:** 2nA through 2μA: 70dB; 20μA through 2A: 55dB.

## OHMS

RANGE	MAXIMUM READING	ACCURACY	TEMPERATURE COEFFICIENT	MAXIMUM OPEN-CIRCUIT VOLTAGE
		1 YR., 23° ± 5°C ± (%rdg + counts)	0-18°C & 28-50°C ± (%rdg + counts)/°C	
2 kΩ	1.99999 × 10 <sup>3</sup>	0.2 % + 25	0.01% + 30	5V
20 kΩ	19.9999 × 10 <sup>3</sup>	0.2 % + 10	0.01% + 3	5V
200 kΩ	199.999 × 10 <sup>3</sup>	0.15% + 25	0.01% + 30	5V
2MΩ	1.99999 × 10 <sup>6</sup>	0.15% + 10	0.01% + 3	5V
20MΩ	19.9999 × 10 <sup>6</sup>	0.35% + 25	0.02% + 30	5V
200MΩ	199.999 × 10 <sup>6</sup>	0.35% + 10	0.02% + 3	5V
2 GΩ	1.99999 × 10 <sup>9</sup>	0.35% + 10	0.02% + 0.3	300V
20 GΩ	19.9999 × 10 <sup>9</sup>	1 % + 10	0.15% + 3	300V
200 GΩ	199.999 × 10 <sup>9</sup>	4 % + 10	0.5 % + 0.3	300V
2 TΩ	1.99999 × 10 <sup>12</sup>	10 % + 10	0.5 % + 0.3	300V

**OHMS CURRENT SOURCES:** 2kΩ, 20kΩ: 100μA.  
200kΩ, 2MΩ: 1μA.  
20MΩ, 2GΩ: 10nA.  
20GΩ through 2TΩ: 100pA.

**ANALOG OUTPUT:** Analog output voltage level is the product of the Ohms current source and the resistance being measured.

### ANALOG SETTling TIMES:

To 0.1% of final value, unfiltered, with less than 100pF input capacitance:  
2kΩ through 2MΩ: 5ms.  
20MΩ: 20ms.  
200MΩ: 200ms.

To 10% of final value, unfiltered, using 6191 Guarded Input Adapter with less than 1pF unguarded input capacitance:  
2GΩ: 150ms.  
20GΩ: 1.5s.  
200GΩ: 15s.  
2TΩ: 150s.

## IEEE-488 BUS IMPLEMENTATION

(Requires installation of Model 6193):

**Multiline Commands:** DCL, LLO, SDC, GET.

**Uniline Commands:** IFC, REN, EOI, SRQ, ATN. Compatible with IEEE-488-1978 standard.

## PROGRAMMABLE PARAMETERS:

**Front Panel Controls:** Function, Range, Filter, Zero Check, Zero Correct, Baseline Store, Baseline Suppress.

**Internal Parameters:** SRQ Response, Trigger Modes, Binary or ASCII Data Formats, number of readings to be stored, data terminators, reading rates, integration period.

**ADDRESS MODES:** TALK ONLY and ADDRESSABLE.

## READING RATES

Programmed Reading Rate	Number Of Integrations Averaged	Time Per Integration (ms)	Trigger To First Byte (ms)	Readings Per Second
S0	1	4.1	32 (18 binary)	40
S1	1	16.67*	35	21
S2	2	16.67*	80	10
S3	4	16.67*	168	5.4
S4	1	100	120	4.7
S5	2	100	328	2.4
S6	4	100	742	1.2
S7	8	100	1680	0.6
S8	16	100	3360	0.3
S9	32	100	6720	0.15

\*20 @ 50Hz.

## GENERAL

**DISPLAY:** Numeric; 0.56" LED digits, 4½-digit mantissa @ 6.2rdg/s (5½-digits @ 2.4 rdg/s in high resolution mode), 2 digit exponent, decimal point, signed exponent and mantissa.

**OVERRANGE INDICATION:** Display reads OFLO.

**MAXIMUM ALLOWABLE INPUT:** 250V rms DC to 60Hz sinewave.

**INPUT CURRENT (18°-28°C):** Less than 0.4pA.

**EXTERNAL TRIGGER:** TTL compatible EXTERNAL TRIGGER and ELECTROMETER COMPLETE.

**INPUT CONNECTORS (6194 Electrometer rear panel):** 2A range: 5-way binding posts. All other functions and ranges via Teflon® insulated triaxial connector.

**OUTPUT CONNECTORS:** Analog: Amphenol Series 80 (Microphone), 6194 Electrometer rear panel. IEEE: Amphenol or Cinch Series 57, 6193 IEEE interface rear panel. BNC (chassis isolated) connections for EXTERNAL TRIGGER and ELECTROMETER COMPLETE.

### MAXIMUM ALLOWABLE COMMON MODE VOLTAGES:

Input LO (Channel A) to line ground: 250V rms, DC to 60Hz sinewave.  
Input LO (Channel B) to line ground: 250V rms, DC to 60Hz sinewave.  
Input LO (Channel A) to Input LO (Channel B): 250V rms, DC to 60Hz sinewave.

**WARMUP:** 1 hour to rated accuracy.

**POWER:** 90-110, 105-125, 180-220 or 210-250V, 50 or 60Hz (internal switch selected). 75W max., 100V•A max. (internally fan cooled).

**ENVIRONMENTAL LIMITS:** Operating: 0°-50°C, up to 35°C at 70% non-condensing R.H. Storage: -20°C to 70°C.

**DIMENSIONS, WEIGHT:** 432mm wide × 127mm high × 406mm deep (17" × 5" × 16"), stackable enclosure. Net weight, 9.8kg (22 lbs.) with Channel B Electrometer module and IEEE-488 Interface module.

**ACCESSORIES SUPPLIED:** One Model 6194 Electrometer Module and one Model 6011 Input Cable.

### ACCESSORIES AVAILABLE:

Model 1019A: 5½" Universal Fixed Rack Mounting Kit  
Model 1019S: Universal Slide Rack Mounting Kit  
Model 6011: Triaxial Input Cable, 1m (3 ft.)  
Model 6191: Guarded Input Adapter  
Model 6193: IEEE-488 Interface  
Model 6194: Electrometer Module  
Model 6195: Maintenance Kit  
Model 7008-3: IEEE-488 Cable (3 ft.)  
Model 7008-6: IEEE-488 Cable (6 ft.)

# TABLE OF CONTENTS

Paragraph	Title	Page
<b>SECTION 1. GENERAL INFORMATION</b>		
1.1	Introduction .....	1-1
1.2	Features .....	1-1
1.3	Warranty Information .....	1-1
1.4	Manual Addenda .....	1-1
1.5	Safety Symbols and Terms .....	1-1
1.6	Unpacking and Inspection .....	1-1
1.7	Specifications .....	1-1
<b>SECTION 2. OPERATION</b>		
2.1	Introduction .....	2-1
2.2	Preparation for Use .....	2-1
2.3	Pre-power Up Programming .....	2-1
2.4	Power Up .....	2-1
2.5	Beeper Selection .....	2-1
2.6	TAlk Only Mode/ Addressable Mode Selection .....	2-1
2.7	Reading Rate Selection .....	2-3
2.8	Operating Instructions .....	2-3
2.9	Front Panel Functions .....	2-3
2.9.1	Annunciator and Display Group .....	2-3
2.9.2	Function Selector Group .....	2-3
2.9.3	Dual Channel .....	2-4
2.9.4	Volts, Amps and Ohms .....	2-4
2.9.5	Range Selection .....	2-5
2.9.6	Zero Controls .....	2-5
2.9.7	Baseline Controls .....	2-6
2.9.8	Filter .....	2-6
2.9.9	Resolution .....	2-7
2.9.10	Current Ranges, Common Input .....	2-7
2.10	External Feedback Use .....	2-7
2.10.1	External Trigger .....	2-8
2.10.2	Charge .....	2-8
2.10.3	Logarithmic Currents .....	2-9
2.11	Non-Decade Current Gains .....	2-9
2.12	System Operation (Using the Model 6193 IEEE-488 Interface) .....	2-10
2.13	Address Selection .....	2-10
2.14	Bus Management Lines .....	2-10
2.14.1	Bus Commands Implemented .....	2-10
2.14.2	Input Channel Control (Secondary Address is a or b) .....	2-11
2.15	Data Format .....	2-11
2.16	ASCII Format .....	2-11
2.17	Binary Format .....	2-11
2.18	Programmable Terminator .....	2-14
2.19	Buffer Readings .....	2-14
2.20	Measurement Time .....	2-15
2.21	Reading Rate Modes .....	2-16
2.22	Filter .....	2-16
2.23	Zero Check .....	2-16
2.24	Zero Correct .....	2-16
2.25	Baseline Store .....	2-16
2.26	Baseline Suppression .....	2-16
2.27	Default Conditions .....	2-16
2.28	Talk-Only Mode .....	2-18
2.29	SRQ Status Byte Format .....	2-18
2.30	Machine Status .....	2-18

## TABLE OF CONTENTS (CONT.)

Paragraph	Title	Page
<b>SECTION 3. ACCESSORIES</b>		
3.1	Introduction .....	3-1
3.2	Model 6191 Guarded Input Adapter .....	3-1
3.3	Model 6193 IEEE Standard 488 Output .....	3-1
3.4	Model 6194 Electrometer Module .....	3-2
3.5	Model 6195 Calibration Cover .....	3-2
3.6	Model 6199 Rack Mounting Kit with Chassis Slides .....	3-3
3.7	Model 7008 IEEE-488 Digital Cable .....	3-3
3.8	Model 6011 Triax Input Cable .....	3-3
<b>SECTION 4. PERFORMANCE VERIFICATION</b>		
4.1	Introduction .....	4-1
4.1.1	Required Test Equipment .....	4-1
4.1.2	Environmental Conditions .....	4-1
4.2	Model 619 Performance Verification .....	4-1
4.2.1	Initial Conditions .....	4-1
4.2.2	Voltage Verification .....	4-1
4.2.3	Current Verification .....	4-1
4.2.4	Resistance Verification .....	4-2
<b>SECTION 5. THEORY OF OPERATION</b>		
5.1	Introduction .....	5-1
5.2	Power Supply .....	5-1
5.3	Model 6194 Electrometer Module .....	5-2
5.3.1	Theory of Operation for the Model 6194 Electrometer Module .....	5-2
5.4	Model 6193 IEEE-488 Interface Board .....	5-5
5.4.1	IEEE Interface Board Theory of Operation .....	5-5
5.5	CPU Board .....	5-7
5.5.1	CPU Theory of Operation .....	5-7
5.6	Isolator Board .....	5-9
5.6.1	Isolator Board Theory of Operation .....	5-11
5.7	Display/Keyboard .....	5-12
5.7.1	Display/Keyboard Theory of Operation .....	5-12
5.8	A/D Board .....	5-13
5.8.1	A/D Theory of Operation .....	5-13
5.9	Filter/Multiplexer Board .....	5-14
<b>SECTION 6. MAINTENANCE</b>		
6.1	Introduction .....	6-1
6.2	Pre-Power Up Programming .....	6-1
6.2.1	Line Voltage and Frequency Selection .....	6-1
6.3	Beeper Selection .....	6-1
6.4	Reading Rate Selection .....	6-2
6.5	Calibration Introduction .....	6-2
6.6	Calibration/Test Equipment and Conditions .....	6-3
6.6.1	Recommended Test Equipment and Related Information .....	6-3
6.7	Information and Assumptions .....	6-3
6.7.1	Standards .....	6-3
6.8	Volts .....	6-3
6.9	Amps .....	6-4
6.10	Ohms .....	6-5
6.11	Environmental Conditions .....	6-5
6.12	Calibration .....	6-5
6.13	Calibration Cover Installation .....	6-5
6.14	Calibration Adjustments .....	6-5

## TABLE OF CONTENTS (CONT.)

Paragraph	Title	Page
6.15	Calibration Fixture .....	6-8
6.16	Construction Information .....	6-9
6.17	Calibration of 1.9GΩ Source .....	6-9
6.18	Troubleshooting .....	6-9
6.18.1	Special Handling of Static Sensitive Devices .....	6-9
6.18.2	Troubleshooting Procedure .....	6-10
6.19	Fan Filter Cleaning .....	6-10
<b>SECTION 7. REPLACEABLE PARTS</b>		
7.1	Introduction .....	7-1
7.2	Parts List .....	7-1
7.3	Ordering Information .....	7-1
7.4	Factory Service .....	7-1
7-5	Schematic Diagrams and Component Location Drawings .....	7-1

## LIST OF ILLUSTRATIONS

Figure	Title	Page
2-1	Model 619 Rear Panel	2-2
2-2	Model 619 Front Panel Functions	2-2
2-3	Common Input Current Range	2-7
2-4	Model 6194 Electrometer Input Circuitry	2-8
2-5	Charge Measurement	2-9
2-6	Logarithmic Current Measurement	2-9
2-7	Non-Decade Current Gain Measurement	2-10
2-8	Timing Diagram	2-12
2-9	Start of Signal Integrate From Trigger (t <sub>1</sub> ) (Trigger is a Negative Going Pulse)	2-13
2-10	Binary Format	2-15
2-11	Status Byte	2-19
2-12	Machine Status	2-19
3-1	Model 6191 Guarded Adapter	3-1
3-2	Model 6193 IEEE Standard 488 Output	3-1
3-3	Model 6194 Electrometer Module	3-2
3-4	Model 6195 Maintenance Kit	3-2
3-5	Model 6199 Rack Mounting Kit with Chassis Slides	3-3
3-6	Model 6011 Triax Input Cable	3-3
4-1	Resistance Source Shielding	4-3
4-2	Resistance Source Shielding and Guarding	4-3
4-3	Measuring Resistance Sources Using Model 6191	4-3
5-1	Model 619 Block Diagram	5-1
5-2	Power Supply	5-2
5-3	Electrometer Module Block Diagram	5-3
5-4	Data Bus Buffer	5-7
5-5	Memory Map	5-10
6-1	Isolator Board and Switches	6-2
6-2	Calibration Cover	6-6
6-3	Supply Calibration .200mV	6-7
6-4	Supply Calibration 2 Volt	6-7
6-5	Range Calibration 20mA	6-7
6-6	Range Calibration 20nA	6-8
6-7	Range Calibration 20kΩ	6-8
6-8	Range Calibration 20GΩ	6-9
6-9	Calibration Fixture Schematic Diagram	6-10
6-10	Model 6191 Guarded Adapter	6-11
6-11	Integrator Output Waveform	6-12
7-1	Mother Board 30411C	7-31
7-2	Display Board 32003D	7-33
7-3	Power Supply Board 32004D	7-37
7-4	IEEE Interface Board 30329D	7-39
7-5	Processor Board 32005D	7-41
7-6	Isolator Board 32006D	7-43
7-7	A/D Converter Board 30395D	7-45
7-8	Electrometer Module Board 30387D	7-47
7-8	Electrometer Module Board 30391D	7-49

## LIST OF ILLUSTRATIONS (CONT.)

Figure	Title	Page
7-9	Filter Mux Board 30352D .....	7-51
7-10	Mother Board Schematic 30517D .....	7-53
7-11	Display Board Schematic 30515D .....	7-55
7-12	Power Supply Schematic 30516D .....	7-57
7-13	IEEE Interface Schematic 30518D .....	7-59
7-14	Processor Schematic (CPU) 30519D .....	7-61
7-15	Isolator Schematic 30520D .....	7-63
7-16	A/D Converter Schematic 30521D .....	7-65
7-17	Electrometer Module Schematic 30522D .....	7-67
7-17	Electrometer Module Schematic 30523D .....	7-69
7-18	Filter Mux Schematic 30524D .....	7-71

## LIST OF TABLES

Table	Title	Page
2-1	Maximum Input .....	2-3
2-2	External Feedback Measurements .....	2-5
2-3	C <sub>FB</sub> Selection .....	2-10
2-4	Secondary Address .....	2-10
2-5	Function .....	2-11
2-6	Range .....	2-11
2-7	Continuous Times (Typical) in Milliseconds .....	2-13
2-8	One Shot Times (Typical) in Milliseconds (Trigger to First Byte Delay) .....	2-14
2-9	Operating Function Format .....	2-15
2-10	Data Terminators .....	2-16
2-11	Data Storage Buffer Commands .....	2-16
2-12	Additional Trigger Time to First Byte Time .....	2-16
2-13	Reading Rate Modes .....	2-17
2-14	Error Codes .....	2-19
2-15	Data Codes .....	2-19
2-16	Byte Definitions .....	2-20
4-1	DC Voltage Performance Check .....	4-2
4-2	DC Current Performance Check .....	4-2
4-3	Ohms Reference Check .....	4-2
5-1	Register Commands .....	5-6
5-2	Register Commands .....	5-8
5-3	Jumpers for PROM Selection .....	5-9
5-4	Register Commands .....	5-11
5-5	Analog Bus Connector Pin Assignments Valid for Channel A .....	5-16
5-6	Analog Bus Connector Pin Assignments Valid for Channel B .....	5-17
5-7	Electrometer Control .....	5-18
5-8	Control Data Bit Designations .....	5-19
6-1	Line Voltage Selections .....	6-1
6-2	Recommended Test Equipment .....	6-4
6-3	Static Sensitive Devices .....	6-10
7-1	Cross-Reference of Manufacturers .....	7-2
7-2	Display Board PC-514, Parts List .....	7-4
7-3	Power Supply PC-515, Parts List .....	7-8
7-4	IEEE Interface PC-517, Parts List .....	7-10
7-5	CPU Board PC-518, Parts List .....	7-12
7-6	Isolator Board PC-519, Parts List .....	7-15
7-7	A/D Converter PC-520, Parts List .....	7-18
7-8	Electrometer Module PC-523 and PC-522, Parts List .....	7-20
7-9	Filter Mux Board PC-521, Parts List .....	7-26
7-10	Fan Assembly, Parts List .....	7-30



# SECTION 1

## GENERAL INFORMATION

### 1.1 INTRODUCTION

The Keithley Model 619 is a fully programmable, micro-processor based Electrometer/Multimeter. Its broad measurement range is from 2nA, with 100fA ( $10^{-13}$ A) resolution on the most sensitive range, to 2A. The Model 619 ohms measurement range is from 2k ( $0.1\Omega$  resolution) to 2T. The volts measurement range is from 200mV ( $1\mu$ V resolution) to 200V. The Model 619 is capable of 0.0005% resolution. It can be interfaced to any programmable measurement system utilizing the IEEE-488 Interface bus. (See Figures 2-1 and 2-2 for front and rear panel detail.)

### 1.2 FEATURES

The Model 619 includes the following features:

- Resolution of  $4\frac{1}{2}$  or  $5\frac{1}{2}$  is standard with the Model 619. Resolution of  $3\frac{1}{2}$  is available only when programmed through the IEEE-488 bus.
- The IEEE-488 Interface option (Model 6193) enables the Model 619 to be incorporated into a measurement system that utilizes programmed control through the IEEE-488 bus.
- The modular construction concept allows for future development of a line of interfaceable products.
- Whenever two Model 6194 Electrometer Modules are installed, there are two separate input channels. Channels A and B measure separately through the READ command and they are separately switched into the A/D Converter. Channel B is an option.
- Ratio A/B takes a ratio of the two channels, always dividing A by B.
- Difference A-B subtracts the electrometer value of Channel B from Channel A.
- A beeper sounds whenever a front panel push-button switch command is given. The beeper is enabled by Switch 1 on the Isolator Board.
- The Model 6191 Guarded Adapter, in the guarded switch position, reduces the effect of additional input cable capacitance (see paragraph 2.2).

### 1.3 WARRANTY INFORMATION

Warranty information is given on the inside front cover of this instruction manual. If there is a need to exercise the warranty, contact the Keithley representative in your area to determine the proper action to be taken. Keithley maintains service facilities in the United Kingdom and West Germany, as well as in the United States. Check the inside front cover of this manual for addresses.

The Model 619 and its installed options can be returned to Keithley for repair and calibration. Also, the Model 619 options (Models 6191, 6193, 6194 and 7008) can be returned to the factory without the basic Model 619. Information for returning the Model 619 and/or its options is given on the inside front cover of this instruction manual.

### 1.4 MANUAL ADDENDA

Improvements or changes to this manual will be explained on an addendum attached to the inside back cover.

### 1.5 SAFETY SYMBOLS AND TERMS

Safety symbols used in this manual are as follows:

The symbol  on the instrument denotes that the user should refer to the operating instructions.

The symbol  on the instrument denotes that 1000V or more may be present on the terminal(s).

The **WARNING** used in this manual explains dangers that could result in personal injury or death.

The **CAUTION** used in this manual explains hazards that could damage the instrument.

### 1.6 UNPACKING AND INSPECTION

The Model 619 was carefully inspected both mechanically and electrically before shipment. Upon receiving the Model 619, unpack all items from the shipping container and check for any obvious damage which may have occurred during transit. Report any damage to the shipping agent. Retain and use the original packaging materials if reshipment is required. The following items are shipped with all Model 619 orders:

- Model 619 Electrometer/Multimeter with one Model 6194 Electrometer Module and one Model 6011 Triax Input Cable.
- Model 619 Instruction Manual.
- Installed or separate optional accessories per request.
- Warranty Card(s).

### 1.7 SPECIFICATIONS

For Model 619 detailed specifications, refer to specifications that precede this section.

## SECTION 2 OPERATION

### 2.1 INTRODUCTION

This section contains information concerning unpacking, inspection, initial use and operation of the Model 619.

### 2.2 PREPARATION FOR USE

The Model 619 is shipped ready for use on the line voltage marked on its rear panel. The beeper is programmed to be operational, and if the Model 6193 IEEE-488 Output is installed, it will be set to the Addressable mode, binary address 6 (00110).

#### NOTE

The following procedure can be used to either confirm the factory setting or to set up the instrument for other modes of operation.

### 2.3 PRE-POWER UP PROGRAMMING

The top cover of the Model 619 must be removed to check or change the LINE VOLTAGE, LINE FREQUENCY, and BEEPER switches. To remove the top cover, refer to Section 6 Maintenance.

### 2.4 POWER UP

During power up, all LED annunciators, other than seven-segment displays, will momentarily light indicating they are functioning properly, and the Model 619 will go to the default conditions given in paragraph 2.27.

During power up, the Model 619 will do a RAM test using test patterns. If the RAM test fails, the bad chip will be indicated by a blinking annunciator as follows.

Low	BYTE	Low	1k	RAM	U919	CH.A
High	BYTE	Low	1k	RAM	U920	CH.B
Low	BYTE	High	1k	RAM	U922	RATIO
High	BYTE	High	1k	RAM	U923	DIFF

During power up, the Model 619 will do a cyclic redundancy check (CRC) on its PROM memory. If PROM test fails, it will be indicated by blinking annunciators as follows:

CHANNEL, CH B, RATIO, DIFF (All Blinking)

During power up the Model 619 displays the current software revision level and line frequency selected as follows:

Frequency	Current Software
Designation: F60 for 60 Hz	Revision Level: C-2
F50 for 50 Hz	C-2

During power up, the Model 619 will check the operation of each module in the unit as follows:

1. If Channel A is not present or malfunctions, "no ch-A" will be displayed.
2. If Channel B is not present or malfunctions, "no ch-B" will be displayed.
3. If the Filter/Mux or A/D are either not present or they malfunction, "no A-d" will be displayed.
4. If the Isolator is not present or malfunctions, "no ISO" will be displayed.

#### NOTE

During operation, the Isolator is doing error checking on data going across the Isolator.

In sending data, if after eight retries the data is not sent correctly a "SND E" will occur and the transmission is attempted again eight more times. This process continues until the data is correct.

In receiving data, if after eight retries the data is not received correctly, "REC E" will occur and the reception is attempted again eight more times. This process continues until the data is correct.

### 2.5 BEEPER SELECTION

When a button is depressed and the Model 619 circuitry recognizes it, the beeper will sound momentarily. Illegal conditions not recognized by error messages will not beep (i.e., highest range and uprange).

The beeper is programmed to be operational at the factory; however, it can be disabled if so desired. To disable the beeper, refer to Section 6 Maintenance.

### 2.6 TALK ONLY MODE/ADDRESSABLE MODE SELECTION (see Figure 2-1)

If the Model 6193 IEEE-488 Output is installed, it will be factory set to the Addressable mode at binary address 6. When in the Addressable mode, RATIO A/B and DIFFERENCE A-B are disabled. A different address can be selected by setting switches A1 through A5 of S701 and putting the Model 619 through the power up cycle (see Note). The switches permit five-bit binary selection of addresses 0 to 31.

The Talk Only mode can be selected by setting switch 7 to the closed (0) position and putting the Model 619 through the power up cycle (see Note). When in the Talk Only mode, the address switches are disabled. In this mode the TALK ONLY and TALK LED's will light.

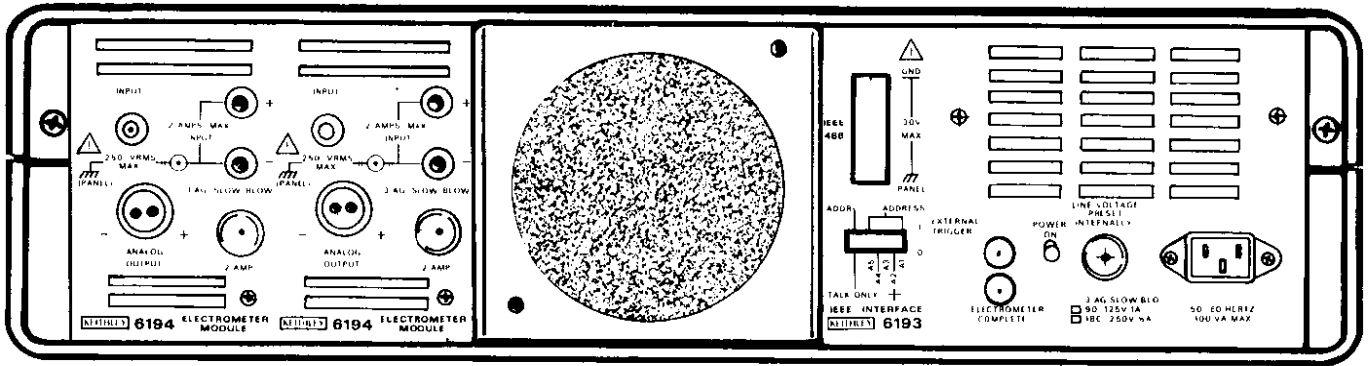

Figure 2-1. Model 619 Rear Panel

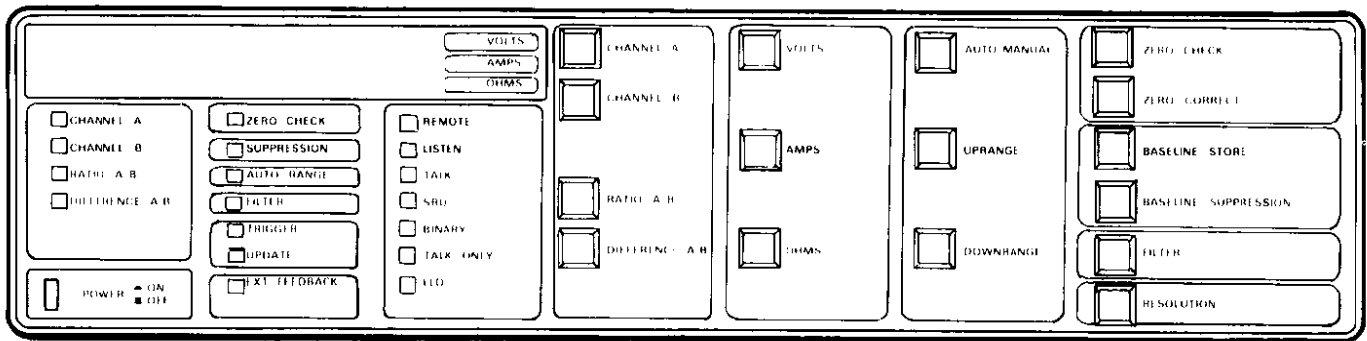

Figure 2-2. Model 619 Front Panel Functions

## NOTE

In order for the Model 619 to accept an address or mode change, the instrument must go through the power up cycle. If the Model 619 is already on, turn it OFF and then back to ON.

## 2.7 READING RATE SELECTION

When the Model 619 is in the Front Panel mode and the 5 1/2 digit resolution mode, two different reading rates can be chosen via S5 (2.41 rdg/sec) or S8 (0.30 rdg/sec). See Table 2-6. To select the S5 reading rate, refer to Section 6 Maintenance.

## 2.8 OPERATING INSTRUCTIONS

The basic operating instructions for the Model 619 are outlined in the following paragraphs. Variations and more complicated measurements will be described later in this section.

1. The Model 619 is provided with a three-wire line cord which mates with third-wire grounded receptacles.

### WARNING

**Ground the instrument through a properly earth-grounded receptacle before operation. Failure to ground the instrument can result in severe injury or death in the event of short circuit or malfunction. In addition, connect only to the line voltage selected. Application of incorrect voltage can damage the instrument.**

2. Turn on the power by depressing the ON/OFF push button in the lower left-hand corner of the front panel (see Figure 2-2). Allow one hour for warm up. An additional hour may be required for temperature extremes. Note that the rear panel power switch must also be in the ON position.
3. Upon power up, the Model 619 will go to the default conditions and a beeper will sound for approximately two seconds. The selected frequency and software revision level will also be momentarily displayed. To change any of the default conditions, refer to paragraph 2.27. Input connectors are located on the rear panel of the Model 6194 Electrometer Module. The main input is in the triax connector, with a separate input for the 2 Amp range. An Analog Output is provided for convenience on a DIN connector (refer to Figure 2-2). Connect the measurement source to the input terminals and make the desired measurement. See Table 2-1 for maximum input.

## 2.9 FRONT PANEL FUNCTIONS

The Model 619 Front Panel has two functional groups, an Annunciator and Display Group and a Function Selector Group. See Figure 2-2.

Table 2-1. Maximum Input

Function	Range	Maximum Input
DCV	200mV, 2V	250V RMS, DC to 60Hz sinewave
AMPS	2nA, 20nA, 200nA 2μA, 20μA, 200μA 2mA, 20mA 2A	250V RMS, DC to 60Hz sinewave 250V RMS, DC to 60Hz sinewave, Fuse Protected
OHMS	2kΩ, 20kΩ, 200kΩ 2MΩ, 20MΩ, 200MΩ 2GΩ, 20GΩ, 200GΩ 2TΩ	250V RMS, DC to 60Hz sinewave

### 2.9.1 Annunciator and Display Group

The software or manually selected status of the Model 619 may be determined at any time by looking at the Annunciators. There are four Annunciator Groups; Status Blocks A, B, C and D.

1. Status Block A indicates the channel status as either Channel A, Channel B, Ratio A/B, or Difference A-B.
2. Status Block B indicates the status of other functions including, Zero Check, Suppression, Auto Range, Filter, Trigger, Update, and External Feedback.
3. Status Block C indicates the IEEE-488 bus status as Remote, Listen, Talk, SRQ, Binary, Talk Only, or LLO.
4. Status Block D indicates the measurement; Volts, Amps, or Ohms.

The 8-Digit Display next to Status Block D indicates the measured value, power, and sign of the input to the Model 619 Electrometer/Multimeter. In addition to these Status Blocks, status may also be determined by controller sampling through the IEEE-488 bus.

### 2.9.2 Function Selector Group

The Function Selector Group consists of seven blocks; Dual Channel including Ratio and Difference, Volts-Amps-Ohms, Range Selection, Zero Controls, Baseline Controls, Filter, and Resolution.

### NOTE

Note that all front panel operations described below, except Ratio and Difference, may be programmed or controlled from the IEEE-488 bus using the optional Model 6193 Interface. In Remote (or Manual) mode, the Model 619 front panel selector push-button switches are active unless LLO is commanded through the bus.

### 2.9.3 Dual Channel

Whenever the Model 619 has a second Model 6194 Electrometer Module installed, Channel A or B may be selected from the front panel or bus. The two channels are independent so that they operate as two separate instruments and can be separately programmed.

1. Channel A
  - A. Upon power up of the Model 619, CHANNEL A will be displayed in the Channel Status Block.
  - B. Otherwise, depressing the CHANNEL A push button will:
    - (a) Display CHANNEL A data.
    - (b) Light the CHANNEL A annunciator.
2. Channel B
  - A. Depressing the CHANNEL B push button will:
    - (a) Display CHANNEL B data.
    - (b) Light the CHANNEL B annunciator.
  - B. If there is no Channel B installed in the Model 619, depressing the CHANNEL B push button will:
    - (a) Display the error message "no ch-b."
    - (b) Return the Model 619 to the previous operating mode.
3. Ratio A/B and Difference A-B. In any Function or Range the Ratio or Difference between Channel A and B, from  $10^{-18}$  to  $10^{+18}$ , may be calculated and displayed.

#### NOTE

The Model 6193 IEEE-488 Interface must be in the Talk Only mode or else not installed for Ratio and Difference operations.

- A. Ratio A/B
  - (a) If the Model 619 is in the Addressable mode, the RATIO A/B command is locked out and cannot be selected.
  - (b) Otherwise, when the RATIO A/B push button is depressed the Model 619 will:
    1. Light RATIO A/B annunciator.
    2. Take one reading at 4.8rdg/sec rate on Channel A.
    3. Take one reading at 4.8rdg/sec rate on Channel B.
    4. Compute the ratio.
    5. Display the ratio at 2.4rdg/sec rate with  $5\frac{1}{2}$  digit resolution.
    6. Repeat the above sequence.
  - (c) If there is no Channel B installed, depressing the RATIO A/B push button will:
    1. Display the error message "no ch-b."
    2. Return to the previous operating mode.
- B. Difference A-B
  - (a) If the Model 619 is in the Addressable mode, this command is locked out and cannot be selected.
  - (b) Otherwise, when the DIFFERENCE A-B push button is depressed the Model 619 will:

1. Light the DIFFERENCE A-B annunciator.
  2. Take one reading at 4.8rdg/sec rate on Channel A.
  3. Take one reading at 4.8rdg/sec rate on Channel B.
  4. Compute the difference.
  5. Display the difference at a 2.4rdg/sec rate, with a  $5\frac{1}{2}$ -digit resolution.
  6. Repeat the above sequence.
- (c) If there is no Channel B installed, depressing the DIFFERENCE A-B push button will:
1. Display the error message "no ch-b."
  2. Return to the previous operating mode.

#### NOTE

Observe that the largest value that can be displayed in the Ratio or Difference mode is  $1999.99 \times 10^{18}$ . The smallest value that can be displayed is  $0.00000 \times 10^{-18}$ . Any time a division by zero is attempted, the display message is "OFLO" (overflow). The data used internally by the Model 619 is to a higher resolution than the displayed reading. Therefore, a display of all zeros on Channel B will not necessarily result in a RATIO "OFLO."

### 2.9.4 Volts, Amps, and Ohms

Volts, Amps, or Ohms functions may be manually selected for a wide range of measurements. Programmed or software selected may also be obtained through the IEEE-488 Interface bus.

#### NOTE

In resistance and voltage modes, analog output is noninverted and can be used for guarding.

1. Volts
  - A. Upon power up the Model 619 will go to the Volts function.
  - B. If the Model 619 is in the Ratio A/B or the Difference A-B mode, this command is locked out and cannot be selected.
  - C. Otherwise, selecting the Volts function for the currently displayed channel will:
    - (a) Light the VOLTS annunciator.
    - (b) Program the Electrometer for the Volts function.
2. Amps
  - A. If the Model 619 is in the Ratio A/B or the Difference A-B mode, this command is locked out.
  - B. Otherwise, selecting the Amps function for the currently displayed channel will:
    - (a) Light the AMPS annunciator.
    - (b) Program the Electrometer for the Amps function.

3. Ohms

- A. If the Model 619 is in the Ratio A/B or the Difference A-B mode, this command is locked out.
- B. Otherwise, selecting the Ohms function for the currently displayed channel will:
  - (a) Light the OHMS annunciator.
  - (b) Program the Electrometer for the Ohms function.

2.9.5 Range Selection

1. Auto/Manual

- A. Auto or manual range may be selected by pressing the appropriate front panel button or by programming on the Interface bus.
- B. If the Model 619 is in the Ratio A/B or the Difference A-B mode, this command is locked out.
- C. If the channel currently being displayed is in AUTO RANGE, depressing the AUTO/MANUAL push button will:
  - (a) Turn off the AUTO RANGE annunciator.
  - (b) Place Model 619 into Manual Ranging.
  - (c) Then hold the present range.
- D. If the channel currently being displayed is in Manual Ranging, depressing the AUTO/MANUAL push button will:
  - (a) Light the AUTO RANGE annunciator.
  - (b) Begin Auto Ranging.
  - (c) Hold the previously displayed reading until settled range is found, then display it.
- E. The following ranges cannot be accessed in the Auto Range mode and actuation of Auto/Manual in any of these function range combinations will result in an error display of "noAU":
  - (a) 2 Amp Range. This range requires a separate input.
  - (b) External Feedback (Amps Function).
  - (c) 2G Ohm through 2T Ohm Range. These high resistances require long time constants.

2. Uprange/Downrange. Manual ranges are advanced up or down by pressing the appropriate front panel button. The desired range may also be programmed on the Interface bus.

A. Uprange

- (a) If either RATIO A/B or DIFFERENCE A-B is selected, this command is locked out and cannot be accomplished.
- (b) If the channel currently being displayed is in AUTO RANGE, depressing the UPRANGE button will place the Model 619 in Manual Ranging and advance Uprange one step.
- (c) If the channel currently being displayed is in MANUAL RANGE, depressing the UPRANGE push button will advance Uprange one step.
- (d) If the channel currently being displayed is in MANUAL RANGE and on the highest possible range for that function, depressing the UPRANGE push button will be ineffective.

B. Downrange. Downrange operates in the same manner as Uprange.

C. External Feedback. External Feedback is accessible on Amps function by touching or programming UPRANGE on the 2 Amp range.

- (a) If the displayed channel is in AMPS and Range 20 (range above the 2 Amp range), the Model 619 will:
  1. Place the Electrometer in the Ext Feedback mode.
  2. Light the EXT FEEDBACK annunciator.
- (b) All status which were in effect for Range 8 in AMPS are in effect for EXT FEEDBACK.
- (c) Refer to Table 2-2 for measurements which can be made on the Amps function by programming or touching UPRANGE beyond the 2 Amp range.

NOTE

When using a resistive feedback configuration either linear (resistor) or non-linear (log diode junction) additional parallel capacitance will be required for stable operation. See External Feedback Use, paragraph 2-10, also see Keithley App. note #101 "Using the 619 External Feedback."

Analog output will invert in the Amps function, but will not in Volts or Ohms functions. Output levels and gain are given in full specifications.

- (d) The A/D Converter inverts and displays  $V_{out}$  on the 2 Volt range.

Table 2-2. External Feedback Measurements

In Order to Measure	Connect these components between the Input and Analog Output
Charge	Capacitor $V_{out} = -Q/C$
Logarithmic Currents	Log Diode $V_{out} = -(K \log I + \text{constant})$
Non-Decade Current Gains	Non-Decade Resistors, R $V_{out} = -IR$

2.9.6 Zero Controls

When there is voltage offset which must be compensated in making precision measurements, this compensation is automatic using the ZERO CORRECT push button (or by Interface bus command). Compensation corrects for offsets on ranges within the selected channel and function.

## 1. Zero Check

- A. If the displayed Channel (A or B) is not currently in ZERO CHECK, depressing the ZERO CHECK push button will:
  - (a) Program the Electrometer to Zero Check.
  - (b) Light the ZERO CHECK annunciator.
- B. If the displayed Channel (A or B) is currently in ZERO CHECK, depress the ZERO CHECK push button, and the Model 619 will:
  - (a) Turn off ZERO CHECK annunciator.
  - (b) Program the Electrometer out of Zero Check.
- C. If the displayed channel is in AMPS, Range 9, depressing the ZERO CHECK push button will display the error message "no 2AC" (no Zero Check in 2 Amp range).

## 2. Zero Correct

- A. If either RATIO A/B or DIFFERENCE A-B is selected, this command is locked out and cannot be accomplished.
- B. If the Model 619 is not in ZERO CHECK or is 2 Amp current range, depressing the ZERO CORRECT push button will:
  - (a) Display the error message "corr IL"
  - (b) Then return to the previous operating mode.
- C. If the Model 619 is in ZERO CHECK, depressing the ZERO CORRECT push button will:
  - (a) Disable the filter.
  - (b) Put the A/D Converter in times 10 gain mode and in a 16.66msec integration period.
  - (c) Average 2 conversions.
  - (d) Take a reading with the Electrometer attenuator in -1 and then -10.
  - (e) Solve for Electrometer and A/D offsets.
  - (f) Repeat above steps for 100ms integration time period.
  - (g) Return to previous operating mode in Zero Check, compensating for all internal voltage offsets measured during Steps a through f.

### 2.9.7 Baseline Controls

Baseline Controls assist in making relative measurements as referenced to a known value (leakage, operating parameters, etc.). The Model 619 will subtract this amount on all ranges on the particular channel where a baseline is assigned.

#### WARNING

**The Suppression light will blink on the 200 Volt range, indicating a possible high voltage safety hazard.**

#### 1. Baseline Store

- A. If either RATIO A/B or DIFFERENCE A-B is selected, or the instrument is currently displaying "OFLO," this command is locked out and cannot be accomplished.
- B. Otherwise, depressing the BASELINE STORE push button will:

- (a) Store the current reading in the Baseline register assigned to the currently displayed Channel/Function. There are six Baseline registers: Channel A/Volts, Channel A/Amps, Channel A/Ohms, Channel B/Volts, Channel B/Amps, and Channel B/Ohms.
- (b) If in Baseline Suppression mode, take unit out of Baseline Suppression, which will turn off the BASELINE SUPPRESSION annunciator.
- (c) Return to previous operating mode (except Baseline Suppression).

#### 2. Baseline Suppression

- A. If either RATIO A/B or DIFFERENCE A-B is selected, this command is locked out.
- B. If the Model 619 is not currently in the Baseline Suppression mode, depressing the BASELINE SUPPRESSION push button will:
  - (a) Light the BASELINE SUPPRESSION annunciator.
  - (b) Subtract from display the contents of the appropriate Channel/Function Baseline register (e.g., if 0.10 volts is stored in the Channel B/Volts Baseline register, subtract 0.10 Volts from readings on all Channel B voltage ranges).
- C. If the Model 619 is currently in the Baseline Suppression mode, depressing the BASELINE SUPPRESSION push button will:
  - (a) Take unit out of Baseline Suppression.
  - (b) Turn off the BASELINE SUPPRESSION annunciator.

#### WARNING

**If the Model 619 is in the 200 Volt range and in Baseline Suppression, the BASELINE SUPPRESSION annunciator will blink indicating a safety warning. A dangerous voltage level could exist and still be read as a lower voltage as displayed by the instrument. This could present a shock hazard should the operator misinterpret the measurement relative to actual voltage.**

### 2.9.8 Filter

When the Filter is placed in operation, by pressing the FILTER push button or commanding it through the IEEE-488 Interface bus, an additional 25dB of line frequency rejection filtering is applied.

1. If either RATIO A/B or DIFFERENCE A-B is selected, this command is locked out.
2. If the displayed channel is not currently in the Filter mode, depress the FILTER push button and the Model 619 will:
  - A. switch the Filter in.
  - B. Light the FILTER annunciator.
3. If the displayed channel is currently in the Filter mode, depressing the FILTER push button will:
  - A. Switch the Filter out.
  - B. Turn off FILTER annunciator.

### 2.9.9 Resolution

Pressing the RESOLUTION push button provides an extra decade of sensitivity and resolution. This may also be accomplished, by command, on the IEEE-488 Interface bus.

#### NOTE

For example, the 2nA range, in Resolution, will go from 4½ digit, 100Fa, lsd, to 5½ digit, 10fA lsd resolution. Noise is typically a few digits in the fifth place.

1. If either RATIO A/B or DIFFERENCE A-B is selected, this command is locked out.
2. If the Model 619 is currently displaying the 4½ digits, depressing the RESOLUTION push button will:
  - A. Reduce the reading rate to 2.4rdg/sec.
  - B. Increase the display resolution to 5½ digits.
3. If the Model 619 is currently displaying 5½ digits, depressing the RESOLUTION push button will:
  - A. Increase the reading rate to 5.49rdg/sec.
  - B. Reduce the display resolution to 4½ digits.

#### NOTE

Displayed exponents are multiples of three (0, ±3, ±6, ±12, ±15, ±18). The Resolution feature increases only the resolution of the displayed reading.

### 2.9.10 Current Ranges, Common Input

Whenever a common input is required, which would include the 2 Amp range, the following triax adapter may be utilized. In this instance, a single input is used and an external relay connects the 2 Amp current range shunt to the triax input connector on the Model 6194 Electrometer Module. See Figure 2-3.

A 5 Volt control signal, external to the Model 619 Electrometer/ Multimeter, must be supplied to switch the relay to the 2 Amp current range. Any additional leakage current introduced by the relay can be nulled using the BASELINE STORE/BASELINE SUPPRESS feature.

#### WARNING

Care should be exercised in shielding the input from any extraneous pickup. Additionally, if a high common mode voltage is required, the entire circuit should be shielded by the chassis ground to prevent a potential shock hazard.

### 2.10 EXTERNAL FEEDBACK USE

The external feedback current range provides a varied and extensive additional measurement capability to the Model 619 Electrometer/Multimeter. Among these are charge, logarithmic currents, and non-decade current gains.

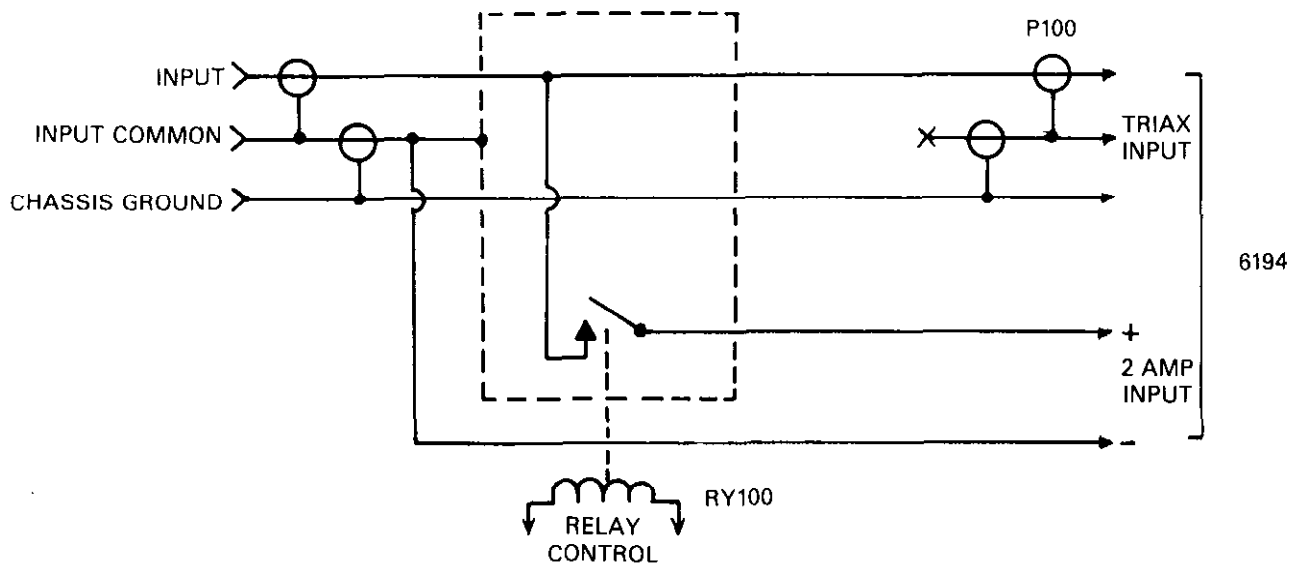

- S100: KEITHLEY CS-253 (POMONA #3580)
- P100: KEITHLEY CS-141 (SPECIALTY CONNECTOR CO. #30P-100-1)
- RY100: KEITHLEY RL-51 (5V-50Ω)

Figure 2-3. Common Input Current Range



The input circuitry used in the Model 6194 Electrometer in the Amps function is configured in the feedback Amps mode as illustrated in Figure 2-4. An input current applied at the negative input of the op amp is nulled with a current through the parallel combination of  $R_{FB}$  and  $C_{FB}$  from the output of the op amp. This is accomplished by the high open-loop gain (typically greater than 40,000) of the op amp which holds its negative input at virtual ground (its positive input which is connected to input common).  $R_{FB}$  in parallel with  $C_{FB}$  converts the input current to a voltage which is further processed by the A/D Converter in the Model 619. Included in this processing is a reinversion of the signal polarity to match that of the actual input.

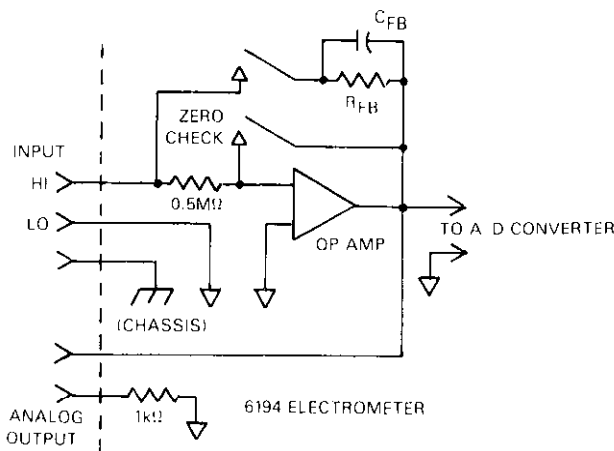

**Figure 2-4. Model 6194 Electrometer Input Circuitry**

The availability of the analog output permits the user to substitute an external network for the combination of  $R_{FB}$  and  $C_{FB}$ . In effectively applying the capability, a number of factors must be taken into account.

1. The total absolute value current supplied by the analog output for both feedback to the input and monitoring of the analog output must be less than 22mA.
2. The Model 619 processes the Model 6194 Electrometer output as a  $\pm 2.0000\text{VDC}$  ( $\pm 2.00000\text{VDC}$  in the  $5\frac{1}{2}$  digit mode) signal correctly inverting the polarity for an accurate representation of the input signal polarity. This output voltage is the level impressed across the external feedback network.
3. Accuracy of the response is the same as that for the 2 Volt range, excluding the contribution of all user-supplied external feedback circuitry. Noise and NMRR will also be a function of this external circuitry.
4. Input impedance is given by the relationship  $Z_{IN} = 0.5\text{M}\Omega \parallel (Z_{FB}/A_V)$ , where  $Z_{FB}$  is the external feedback network and  $A_V$  is the open-loop gain of the op amp (typically greater than 40,000). Note that in Zero Check,  $A_V$  is reduced to unity (1) and that  $\parallel$  represents the

parallel combination of the two quantities separated by this symbol ( $A \parallel B = AB/(A + B)$ ).

5. Selection of the external feedback network must incorporate the proper frequency compensation required by the Model 6194 Electrometer Module.
6. All external feedback circuitry should be housed in a suitably shielded enclosure. Insulators supporting the input node (input HI) should be constructed of Teflon® or other high quality insulator.

### 2.10.1 External Trigger

When the Model 619 is turned on it is in the continuous mode T0. When switch S3 (Figure 6-1, Isolator Board) is switched to ON and the Resolution button is pressed the Model 619 is placed into the one shot mode T1. The T1 mode allows a trigger only from the front panel by pressing the Ratio/Difference button or by the External Trigger.

The external trigger requires a falling edge pulse at TTL logic levels. The trigger voltage should be between, greater than or equal to zero, and less than or equal to +5 volts. The external trigger pulse initiates a measurement conversion. For one shot (T1, T3 and T5) times (trigger to first byte) refer to Table 2-8. For continuous (T0, T2 and T4) times refer to Table 2-7.

#### NOTE

The external trigger is inhibited in the S0 mode or by LLO (local lockout).

Electrometer Complete-The Electrometer Complete output is a  $400\mu\text{sec}$  wide positive pulse that signifies completion of the measurement conversion cycle. The Electrometer Complete line can be used to trigger another instrument or to inform an instrument that the measurement conversion cycle has been completed.

For example: The Model 619 can be used with a scanner. The Electrometer Complete line can trigger the scanner to switch to the next available channel when the Model 619 measurement cycle has been completed.

### 2.10.2 Charge

The measurement of charge can be made directly by using an external feedback capacitor,  $C_{FB}$ , as illustrated in Figure 2-6. In the relationship  $Q = CV$ ,  $Q =$  charge (coulombs) applied to input,  $C =$  capacitance (farads) of  $C_F$ , and  $V =$  voltage (volts) at output as indicated on the display. The Model 619 display will read charge directly in the units determined by  $C$ . For example, using  $1\mu\text{F}$  capacitor will provide a display in  $\mu\text{C}$ .

In practice,  $C_{FB}$  should be greater than 100pF for feedback stability and of a suitable dielectric material to ensure low leakage and low dielectric absorption. Polystyrene and

polypropylene dielectric capacitors offer good performance in this regard.

As shown in Figure 2-5 an external Zero Check contact may be desirable in certain applications where  $0.5M\Omega$  Zero Check input impedance cannot be tolerated.  $R_{LIMIT}$  protects this contact from the discharge surge of  $C_{FB}$ . Care should be exercised in the selection of this contact (switch or relay) that the high impedance, low current requirements of the circuitry are not compromised.

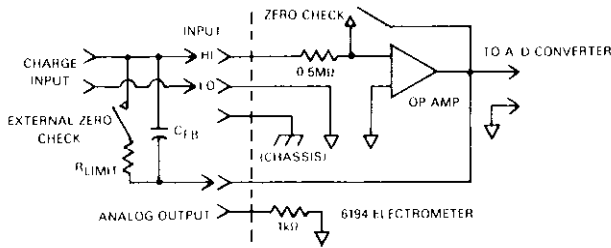

Figure 2-5. Charge Measurement

### 2.10.3 Logarithmic Currents

The use of a diode junction in the external feedback path permits a logarithmic current-to-voltage conversion. This relationship for a junction diode can be given by the equation:

$$V = m \frac{kT}{q} \ln \left( \frac{I}{I_0} \right) + IR_B$$

where  $q$  = unit charge ( $1.6022 \times 10^{-19}C$ ),  $k$  = Boltzmann's constant ( $1.3806 \times 10^{-23}J/^{\circ}K$ ), and  $T$  = Temperature ( $^{\circ}K$ ).

The limitations in this equation center on the factors  $I_0$ ,  $m$ , and  $R_B$ .  $I_0$  is the extrapolated current for  $V=0$ . An empirical proportional constant,  $m$ , accounts for the different character of current conduction (i.e., recombination and diffusion) mechanisms within the junction, typically varying in value between 1 and 2. Finally,  $R_B$  constitutes the ohmic bulk resistance of the diode junction material.  $I_0$  and  $R_B$  limit the usefulness of the junction diode as a log converter at low and high currents, respectively. The factor  $m$  introduces non-linearities between these two extremes. With all these factors taken into account, most diodes have a limited range of useful logarithmic behavior.

A solution to these constraints is the use of a transistor configured as a "transdiode" in the feedback path as shown in Figure 2-6. Analyzing the transistor in this configuration leads to the relationship:

$$V = \frac{kT}{q} \ln \left( \frac{I}{I_0} \ln \left( \frac{h_{FE}}{1 + h_{FE}} \right) \right)$$

where  $h_{FE}$  is the current gain of the transistor.

From this equation, proper selection of transistor Q1 (Figure 2-6) would require a device with a high current gain ( $h_{FE}$ ) which is maintained over a wide range of emitter currents. Suitable devices include Analog Devices AD812 and Precision Monolithics MAT-Q1.

Frequency compensation/stabilization is accomplished by  $C_{FB}$ . Selection of a proper value depends on the particular transistor being used and the maximum current level anticipated. Compensation at the maximum current is required since the dynamic impedance of the transistor will be a minimum at this point. It should be noted that the response speed at lower currents will be compromised due to the increasing dynamic impedance.

$$Z \text{ (impedance)} = 2V/2I = kT/qI = 0.026/I \text{ @}25^{\circ}C$$

Using the MAT-01 or AD818, a minimum RC time constant of  $50\mu\text{sec}$  at maximum input current should be used. At  $I_{IN}(\text{max})$  of  $100\mu\text{A}$ , this would correspond to  $0.2\mu\text{F}$ . Note that at  $100\text{nA}$ , this would increase the RC response time constant to  $50\text{msec}$  (5 sec at  $1\text{nA}$ ). A minimum capacitance of  $100\text{pF}$  is recommended.

Although the input to this configuration is a current source, a voltage source can be used with a suitable ballast resistor. In this configuration, the input burden of  $1\text{mV}$  must be considered as an error source against the input voltage.

Further processing of the response can be accomplished with Baseline Suppression and Ratio. Baseline Suppression provides an offset and Ratio provides a scaling factor (with optional Channel B, Model 6194 Electrometer Module installed). Alternately, a controller (computer) can process the data via the IEEE-488 bus output (with optional Model 6193 IEEE Interface installed).

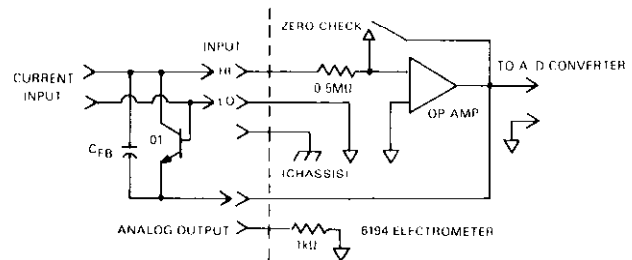
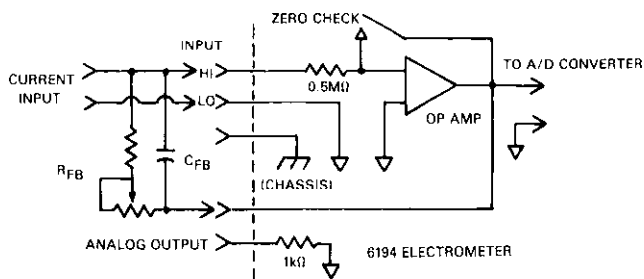

Figure 2-6. Logarithmic Current Measurement

### 2.11 NON-DECADE CURRENT GAINS

The Model 6194 Electrometer uses internal decade resistance feedback networks for the  $2\text{nA}$  through  $20\text{mA}$  current ranges. In some applications a non-decade current-to-voltage conversion (gain) may be desirable. As illustrated in Figure 2-7 a calibratable resistance,  $R_{FB}$ , serves this purpose.



**Figure 2-7. Non-Decade Current Gain Measurement**

Limitations on the value of  $R_{FB}$  require it to be in the range of  $10^2\Omega$  to  $10^{10}\Omega$ . Frequency compensation/stabilization is accomplished by  $C_{FB}$ . Selection of  $C_{FB}$  based on an RC response time should be per Table 2-3 with a minimum value of 100pF:

**TABLE 2-3  $C_{FB}$  SELECTION**

$R_{FB}$	RC Response Time
$10^2$ to $10^3$	50 $\mu$ sec
$10^5$ to $10^6$	500 $\mu$ sec
$10^6$ to $10^7$	5msec
$10^7$ to $10^{10}$	C = 100pF

## 2.12 SYSTEM OPERATION (Using the Model 6193 IEEE-488 Interface)

### 2.13 ADDRESS SELECTION

1. Primary Address. The Primary Address of the Model 619 is selected by 5 switches on the IEEE-488 module (see Figure 2-1). These switches are accessible from the rear panel of the unit. This allows the selection of 31 primary listener/talker address pairs. Binary 11111 is reserved for the Untalk and Unlisten commands.
2. Secondary Address. The Model 619 uses a secondary addressing to distinguish between SRQ requests, commands and data associated with input Channel A and input Channel B. To address the Model 619, the IEEE-488 controller must send the primary address of the Model 619 followed by the secondary address of the desired channel. See Table 2-4 for secondary addresses.

### 2.14 BUS MANAGEMENT LINES

1. Remote Enable (REN). To place the Model 619 into the remote mode, send REN and the appropriate listen address and the remote indicator will light. The statement used to enter the remote mode (i.e. REN and Address) must not contain any other commands. The Model 619 must be in the remote mode to be programmed. If it is

not in the remote mode, the first arguments preceding the remote mode will not program the Model 619 and will cause "NO rN" to be displayed. The Model 619 front panel push-button switches will respond unless LLO is commanded through the bus. Pressing the RATIO button initiates a conversion(s) if a trigger is being awaited by the Model 619 (the RATIO button is a manual trigger during bus operation). After programming, the front panel does not reflect the new configuration until the Model 619 is triggered.

**Table 2-4. Secondary Address**

FUNCTION	ASCII	HEX
Channel A (LISTEN)	a	61 <sub>H</sub>
Channel A (TALK)	a	61 <sub>H</sub>
Channel B (LISTEN)	b	62 <sub>H</sub>
Channel B (TALK)	b	62 <sub>H</sub>
SRQ (TALK)	f	66 <sub>H</sub>
Status Request A (TALK)	c	63 <sub>H</sub>
Status Request B (TALK)	d	64 <sub>H</sub>

2. Interface Clear (IFC). Clears the Interface and goes to talker/listener idle states. There are no state (function, range, etc.) changes in the Model 619.
3. Service Request (SRQ). Requests serial poll service.
4. End (EOI). Asserted during last byte of multi-byte data transfer.
5. Attention (ATN). Asserted when address or commands are present on the bus.

#### 2.14.1 Bus Commands Implemented

1. Universal Commands
  - A. Device Clear (DCL). The Model 619 goes to default conditions (see paragraph 2.27)
  - B. Local Lock Out (LLO). If LLO is given, the front panel controls cannot cause a change in status in the Model 619. (The LLO annunciator will light when in LLO).
  - C. Serial Poll Disable (SPD). Disables serial polling.
  - D. Serial Poll Enable (SPE). When addressed to Talk, the Model 619 will send the SRQ status word.
  - E. Untalk (UNT). Puts the Model 619 into a talker idle state if it was a talker.
  - F. Unlisten (UNL). Puts the Model 619 into a listener idle state if it was a listener.
2. Address Commands
  - A. Selected Device Clear (SDC). If the Model 619 is addressed to listen it will go to default conditions.
  - B. Group Execute Trigger (GET). If the Model 619 is addressed to listen and in the proper trigger mode (T2 or T3), it will automatically trigger a conversion.

## 2.14.2 Input Channel Control (Secondary Address is a or b)

1. Channel. Input Channels A and B can be separately addressed and controlled using secondary addressing. Each input channel has several internal status words which define the current operating status of the channel. When addressed to Talk, the status words define the function, range, and mode of operation by which the data will be accepted. The status words can be modified by the following device dependent commands sent via the bus (see Status Section). In order to program Channel A or Channel B the machine must be in Remote mode.
2. Device Dependent Commands. The following device dependent commands apply to either Channel A or Channel B as defined by the secondary address. Any or all may be used followed by an execute command "X" to initiate the change. Only after the execute command will the change take place. Commands may also be sent in sections, for example:  
 First Commands - Send F1  
 Second Command - Send R2X  
 The above commands are the same as sending F1R2X in one command.
  - A. Function and Range. Refer to Tables 2-5 and 2-6 for function and range information.
  - B. Bus Response Mode
    - (a) MØ Standard. On error or data, the Model 619 will not access SRQ (status byte will still contain up-to-date information if serial poll done).
    - (b) M1 Interrupt. On error or data, the Model 619 will access SRQ when appropriate.
    - (c) Pwr ON/DCL/SDC, Default MØ.
  - C. Trigger Mode (same for both Channels A and B)
    - (a) TØ Continuous on Talk. The Model 619 continuously updates the display at the programmed reading rate after being address to Talk. The output data buffer will be updated at the same rate as the display if the data is read out at the same rate. If the data is not read out, the reading will be held in the output data buffer until it is read out. When it is read out, the next value will then be placed in the buffer.
    - (b) T1 One-Shot on Talk. The Model 619 will update the output data buffer at the programmed rate, once each time a conversion is initiated by being addressed to Talk (to retrigger, address to Talk again) (see Figure 2-8).
    - (c) T2 Continuous on GET. The same as Continuous on Talk except it is done on GET (see Figure 2-8).
    - (d) T3 One-Shot on GET. After a GET command is accepted by the Model 619, it will initiate a conversion. The Model 619 will update the output data buffer once at the programmed reading rate (see Figure 2-8).
    - (e) T4 Continuous on X. The same as Continuous on Talk except it is done on X (see Figure 2-8).

- (f) T5 One-Shot on X. After an "X" command is accepted by the Model 619, it will initiate a conversion. The Model 619 will then update the output data buffer once at the programmed reading rate (see Figure 2-8).
- (g) Pwr ON/DCL/SDC, Default TØ.

**Table 2-5. Function**

Command	Function
FØ	Volts
F1	Amps
F2	Ohms
Power ON/DCL/SDC, Default FØ	

**Table 2-6. Range**

Command	Volts	Amps	Ohms
R0	Auto	Auto	Auto
R1	200mV	2nA	2k
R2	2V	20nA	20k
R3	20V	200nA	200k
R4	200V	2µA	2M
R5	*200V	20µA	20M
R6	*200V	200µA	200M
R7	*200V	2mA	*2G
R8	*200V	20mA	*20G
R9	200V	*2Amps	200G
R:	*200V	**EXT FEEDBACK	*2T
Pwr ON/DCL/SDC, Default R4			

\*Will not autorange into these ranges.

\*\*EXT FEEDBACK is considered to be an Amps range and not an individual function.

## 2.15 DATA FORMAT

1. DØ ASCII Data String. The internal Model 619 priorities are such that ASCII data is passed to the interface after the display is updated (same for Channels A and B).
2. D1 Binary Data String. The internal Model 619 priorities are such that Binary data is passed to the interface before going to the display. The display will be blank except for bus annunciators.

## 2.16 ASCII FORMAT

Channels A and B can be separately addressed to talk using secondary addresses a and b. When the Model 619 is addressed to Talk, it will transmit the current contents of its output data buffer as a 16 to 18 byte ASCII string. The actual length of the ASCII string depends on the number of programmed terminators. Refer to Figures 2-9 and 2-10 and Tables 2-7 through 2-9.

## 2.17 BINARY FORMAT (Refer to Figure 2-11)

1. In the binary data mode, the Binary annunciator will turn ON and the display becomes blank except for the bus annunciators.

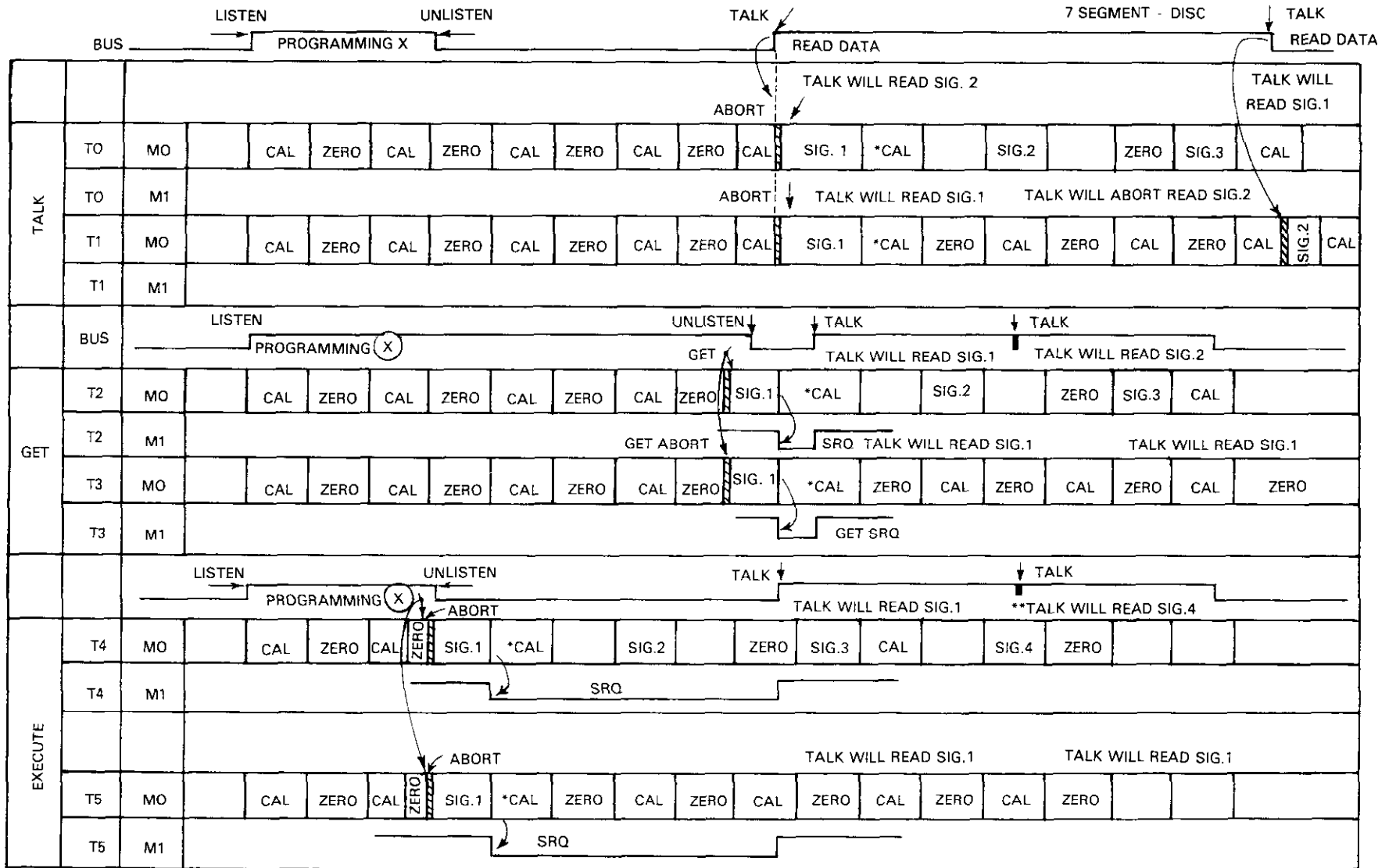

\*Phase to run depends on previous abort or power up.

\*\*Reading held in communications buffer until taken by Bus; only then will a new reading be stuffed.

Figure 2-8. Timing Diagram

**Table 2-7. Continuous Time (Typical) in Milliseconds**

RATE	T0, T2, and T4	
	BIN	ASCII
S0	13	13
S1	41.5	42
S2	81	81
S3	160	160
S4	210	210
S5	412	430

$t_1$ in msec	S0	S1 - S3	S4 - S8
$t_1$	1.1msec	1.1msec	1.1msec

**Figure 2-9. Start of Signal Integrate from Trigger ( $t_1$ )**  
(Trigger is a negative going pulse.)

**Table 2-8. One Shot Times (Typical) in Milliseconds ( $t_{TAB}$ )**

RATE	T1*		T3**		T5**	
	BIN	ASCII	BIN	ASCII	BIN	ASCII
S0	17	28	18	28	40	40
S1	29	33	30	32	43	36
S2	72	76	73	75	87	83
S3	155	160	156	164	170	180
S4	108	112	108	116	122	122
S5	305	305	305	320	320	320
S6	700	700	700	730	720	720
S7	1500	1500	1500	1540	1540	1500
S8	3150	3100	3100	3200	3100	3100
S9	6300	6200	6300	6400	6200	6200

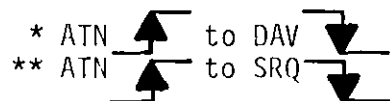

2. Byte 1: (Refer to Figure 2-10)
  - A. Sign Bit - 1 = negative, 0 = positive
  - B. Overflow Bit - 1 = overflow
  - C. Data bits - Most significant 6 bits of absolute value binary data.
3. Byte 2,3: 16-bit binary data.
4. Byte 4: 2's complement binary representation of decimal exponent.
5. Binary Format is not available in "Talk Only" mode.
6. Binary Format is not defined for secondary channels c and d.

**NOTE**

Bus Line E01 is asserted during transmission of the last byte (Dummy byte).

**2.18 PROGRAMMABLE TERMINATOR**

1. The Model 619 utilizes the ASCII Code for terminating data transfer, see Table 2-10. The Model 619 is programmed with a CR LF terminator that is designated as Y (LF) when sent over the bus.

2. However, a different terminator can be programmed into the Model 619. Example: To use A as a terminator, program Y (A) to be sent over the bus. Reserved letters are not usable as terminators.
3. No terminator is used if a Y (DEL) is sent over the bus. The EOI will identify the last byte of the data transfer.
4. On power up of the instrument, the default condition puts the Model 619 back into the CR LF terminator mode.

**2.19 BUFFER READINGS (Same for both Channels A and B)**

Data Storage Buffer commands for buffer contents are shown in Table 2-11.

Q(ASCII): The (ASCII) byte contains an ASCII number from 0 to 5. This number will allow 1-50 readings "T" to be stored going in groups of 10 readings.

1. (ASCII) = 1 says that "T" equals 10 readings (i.e., Q1 says that "T" equals 10 readings).

**Table 2-9. Operating Function Format**

FUNCTION	DATA
Volts	*NDVC ±1. 2 3 4 5 6 E ± 0 9 (Terminators)
Amps	NDCA ±1. 2 3 4 5 6 E ± 0 9 (Terminators)
Ohms	NOHM ±1. 2 3 4 5 6 E ± 0 9 (Terminators)
Ratio**	NRAT ±1. 2 3 4 5 6 E ± 0 9 (Terminators)
Difference**	NDIF ±1. 2 3 4 5 6 E ± 0 9 (Terminators)

\*\*Available in "Talk Only" operation only.

\*N = Normal Reading

0 = Overflow Reading

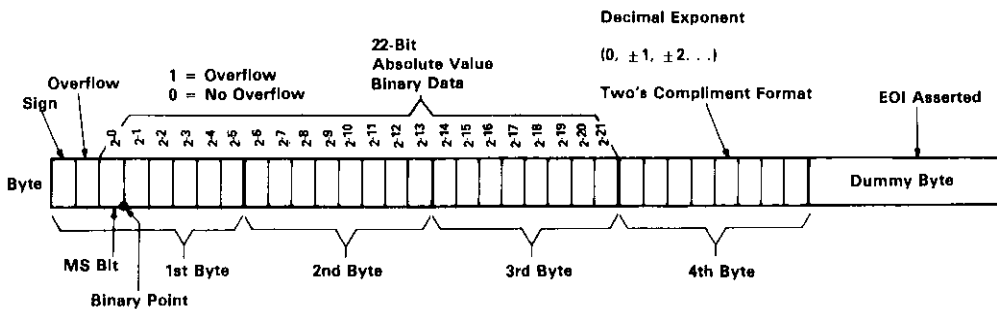

**Figure 2-10. Binary Format**

2. Default is (ASCII= $\emptyset$  or "T" equals 1 reading (i.e., Q $\emptyset$  says that "T" equals 1 reading).
3. To empty the buffer, read "T" readings or reprogram (i.e., give an "X").
4. Data storage buffer must be filled up to the programmed length (multiple of 10 up to 50) before any data is transmitted on the bus. Format is first in, first out. An "X" command clears the buffer.
5. In M1, which is a Bus Response Mode, when the buffer is full it will generate an SRQ (see SRQ Status Byte Format, paragraph 2-29).
6. Cannot use buffer with T5 which is one of six Trigger modes. In the T5 Trigger mode each time an "X" is given, the Model 619 will update the output data buffer and then clear it; therefore, it will never fill up. This will work with T4 Trigger mode since in this mode only one "X" is needed (see Table 2-12).
7. If the Model 619 is in a one-shot Trigger mode, there will be no reading until the buffer is filled up. Therefore, it will take multiple triggers to fill the buffer.

**Table 2-10. Data Terminators**

Y COMMAND	FUNCTION
Y <DEL>	No terminator
Y <CR>	<LF> <CR> dual terminators
Y <LF>	<CR> <LF> dual terminators
Y <CHAR>	CHAR any 8 bit ASCII value except reserved letters E,R,M,T,D,Q,Y,S,P,Z,N,U,X
Pwr ON/DCL/SDC	Default Y <LF>
Note: <CR> = 0D <sub>H</sub> <LF> = 0A <sub>H</sub>	

**Table 2-11. Data Storage Buffer Commands**

COMMAND	FUNCTION
Q $\emptyset$	BUFFER NO READINGS
Q1	BUFFER 10 READINGS
Q2	BUFFER 20 READINGS
Q3	BUFFER 30 READINGS
Q4	BUFFER 40 READINGS
Q5	BUFFER 50 READINGS
Pwr ON/DCL/SDC	Default Q $\emptyset$

**Table 2-12. Typical Trigger Time to First Byte Time**

Change	S $\emptyset$	S1
Function	3 msec	3 msec
Range	3 msec	3 msec
Channel	42 msec	42 msec
Integration (S $\emptyset$ - S1)		114 msec
(S1 - S $\emptyset$ )	48 msec	

## 2.20 MEASUREMENT TIME

The time required to make a measurement is the sum of:

1. Control or command time to the Electrometer or measurement source.
2. The analog settling time. This is specified to 0.1% settling. All time constants are roughly first order.
3. The time from trigger to first byte available.
  - A. This time is specified for various resolutions.
  - B. In addition, time must be added if the conversion is the first on a new range or function, see Table 2-12 for conversion times.
4. Time to transmit data over the bus.
  - A. In ASCII data format, 16 to 18 bytes are to be transmitted (4 in binary mode).
  - B. Time is determined mainly by the controller.
  - C. The Model 619 can transmit data as fast as 57 $\mu$ s per byte. However, in the S0 mode, a 6ms delay occurs with each string.
  - D. If the controller waits more than 5.2msec before obtaining the next byte, the Model 619 may delay completion of the bus handshake by up to 3ms.



## 2.21 READING RATE MODES (See Table 2-13)

The Integration period is measured in milliseconds. Signal zero and calibrate integration periods are equal. When one of the measurement modes is triggered, the A/D will signal integrate, autozero and autocalibrate. The A/D will do a new autozero and autocalibrate if there is time to do them and another trigger is not given.

The Z is autozero; C is autocalibrate; S is signal integrate. The trigger is indicated by a single quotation mark ('). The data is ready signified by double quotation marks ("").

The delays are measured in milliseconds. The IEEE bus has approximately 5.2msec to take a reading once data is available. If the reading is not taken in this time, the retrigger rate will be slowed down and will miss the reading in the continuous mode.

Integration periods for S1, S2, and S3 are for 60Hz line operation. These are changed to 20msec integration periods for 50Hz. For measurement mode S $\emptyset$ , 50/60Hz integration period is 4.1msec. Switch 8 $\emptyset$ 1-S1 on the Isolator board configures A/D timing appropriate for 50/60Hz.

Following a range change or channel changes, two additional integration periods are required for update of zero and calibration.

At sufficiently high trigger rates, autozero and autocalibrate phases are bypassed. When a trigger is given the A/D will do a signal integrate and then autozero and autocalibrate. If the trigger is given before it can autozero and autocalibrate, it will do a signal integrate. Therefore, if trigger is given at a faster rate, autozero and autocalibrate will be bypassed.

In the A $\emptyset$  measurement modes, the front panel push-button switches will not respond. The LLO annunciator will turn on and the display goes blank except for the bus annunciators.

## 2.22 FILTER

1. P $\emptyset$ —The filter is disabled.
2. P1—The filter is enabled.
3. Pwr ON/DCL/SDC, default P $\emptyset$ .

## 2.23 ZERO CHECK

Each channel has either Zero Check ON or OFF (not function dependent, just channel dependent).

1. C $\emptyset$ —The Model 619 is not in Zero Check.
2. C1—The Model 619 is in Zero Check.
3. Pwr ON/DCL/SDC, default C1.

## 2.24 ZERO CORRECT

1. Z $\emptyset$ —Zero Correct table is not updated.
2. Z1—Update Zero Correct table.
3. Pwr ON/DCL/SDC, default Z $\emptyset$ .

There are 6 Zero Correct registers (channel and function dependent)—ch A V, ch A A, ch A  $\Omega$ , ch B V, ch B A, and ch B  $\Omega$ . After power up each register has a  $\emptyset$  in it. To Zero Correct select the desired channel and function (lowest range) and perform the correction. After correction is done, the machine reverts back to the Z $\emptyset$  mode (no need to program Z $\emptyset$  after Z1—the Model 619 does it automatically).

## 2.25 BASELINE STORE

1. N $\emptyset$ —Contents of baseline registers are not updated.
2. N1—Baseline registers are updated, then it returns to N $\emptyset$  mode.
3. Pwr ON/DCL/SDC, default N $\emptyset$ .

There are 6 Baseline Store registers (channel and function dependent) 1—ch A V, ch A A, ch A  $\Omega$ , ch B V and ch B  $\Omega$ . After power up, each register has a 0 in it. To store select the desired channel and function, and perform the storage. The value stored will be used as the correction to the reading when Baseline Suppression is given.

## 2.26 BASELINE SUPPRESSION

1. U $\emptyset$ —The contents of any Baseline register will not be subtracted from the reading.
2. U1—Subtract contents of appropriate Baseline register from reading.
3. Pwr ON/DCL/SDC, default U $\emptyset$ .

### NOTE

For Zero Check, Zero Correct, Baseline Store and Baseline Suppress, a trigger must be provided to complete these commands. For example if in "T1" mode, giving Z1X will only set the Model 619 up to do a Zero Correct, The Model 619 will need to be addressed to talk (since in T1) to complete the command.

## 2.27 DEFAULT CONDITIONS

When an SDC or DCL, Channels A and B will go to the following default conditions:

- F $\emptyset$  - Volts
- R4 - 200V Range
- M $\emptyset$  - Bus Response Mode (Standard)
- T $\emptyset$  - Trigger Mode (Continuous on Talk)
- D $\emptyset$  - Data Format (ASCII Data String)
- Y(LF)— Programmable Terminator (CR)(LF)
- S3 - Measurement Mode
- P $\emptyset$  - Filter (Filter Out)
- C1 - Zero Check (In Zero Check)
- Z $\emptyset$  - Zero Correct (No update of Zero Correct table)
- N $\emptyset$  - Baseline Store (No update of contents in the Baseline register)
- V $\emptyset$  - Baseline Suppression (Do not subtract contents of any Baseline register from reading)

Channel A will be displayed.

Table 2-13. Reading Rate Modes

Mode	Continuous rdg/sec (ASCII)	Conversions Averaged	Integration Period (a,d)	Data† Resolution	Trigger to First** Byte Delay (c,e)		One Shot Sequence (b,f)	Continuous Sequence
					ASCII D0	Binary D1		
S0	40	1	4.1	3½	31.5	18	Z,C,*Z,C...'S'	
S1	21.2	1	16.66	4½	34.5	30.5	Z,C,*Z,C...'S'	...S''CS''C...
S2	10.7	2	16.66	4½	80	75	Z,C,*Z,C...'S,Z,S''	...S''CSZS''C...
S3***	5.49	4	16.66	4½	168	164	Z,C,*Z,C...'S,Z,S,C,S,Z,S''	...S''CSZSCSZS''C...
S4	4.83	1	100	5½	119	112	Z,C,*Z,C...'S'	...S''CSZSCSZS''C...
S5***	2.41	2	100	5½	328	323	Z,C,*Z,C...'S,Z,S''	...S''CSZSCSZS''C...
S6	1.20	4	100	5½	741	736	Z,C,*Z,C...'S,Z,S,C,S,Z,S''	...S''CSZSCSZS''C...
S7	0.60	8	100	5½	1680	1680	Z,C,*Z,C...'S,Z,S,C,S,Z,S'',S...	...S''CSZSCSZS''C...
S8	0.30	16	100	5½	3300	3300	Z,C,*Z,C...'S,Z,S,C,S,Z,S'',S...	...S''CSZSCSZS''C...
S9	0.15	32	100	5½	6700	6700	Z,C,*Z,C...'S,Z,S,C,S,Z,S'',S...	...S''CSZSCSZS''C...

†Bus resolution is always 5½ digits.

\*Must allow ZC time for analog specs.

\*\*In mSec ±250µSec

\*\*\*Available in front panel operation via Resolution pushbutton.

On power up the Model 619 will default to the above conditions. In addition, the Zero Correct table and Baseline registers are cleared. Also if the software Watch Dog detects a processing error the instrument is placed automatically in these default conditions.

## 2.28 TALK-ONLY MODE

The Model 619 may be used with a printer or other nonintelligent devices through the IEEE Bus in Talk-Only mode. This particular mode is selected by SW7 on the IEEE-488 module. (See the sketch regarding SW7). In the Talk-Only mode, ASCII data is sent continuously out to the interface. The front panel will default to these conditions MØ, TØ, DØ, Y(LF). All other device dependent commands (function, range, reading rate, filter, etc.) are selected via the front panel pushbutton. Ratio and difference may be sent in Talk-Only mode, by not in Addressable mode. See Figure 2-1. Address switch A6 is not used as a primary address switch.

### NOTE

In Addressable mode, the following front panel push buttons are non-functional (Commands are locked out):

- RATIO (Only available in Talk-Only mode).
- DIFFERENCE (Only available in Talk-Only mode).

Programming Example (Channel A, Using H.P. 9820 Desk Top Computer Codes).

Let Model 619 primary address = 6 (Binary 00110).

```
? Unlisten
A Talk Address of Controller
6 Primary Address of Model 619
a Secondary Address of Channel A
T
Ø Continuous on Talk
M
Ø Model 619 will not access SRQ on error or data
F
1 Amps
R
4 100nA Range
S
3 6.25 Readings/Second
P
Ø Filter Out (disabled)
D
Ø ASCII Data String
X Execute (This character terminates the command string and causes their execution).
```

The sequence of commands after the secondary address and prior to execute is unimportant except that Baseline Store cannot be in the same line as function or channel change ISBS error (see SRQ status byte formats).

All commands are executed after "X" is given. Only commands that you wish to change need to be programmed.

## 2.29 SRQ STATUS BYTE FORMAT

If an invalid command is given, no change in status will occur. If in the M1 response mode, service will be requested, and the error will be indicated in the SRQ byte. Extensive error checking is done during programming of the Model 619. The errors can be classified into two types; Pre"Execute" errors and Post"Execute" errors.

1. Examples of Pre"Execute" errors:

- A. VX = IddC
- B. V2X = IddC
- C. ggX = IddC
- D. Fggg = IddC (must see and X to accept next command string)
- E. F4X = IddCO

2. Examples of Post"Execute" errors:

Do a Z0 when not in Zero Check (C0).

3. Status Byte (see Figure 2-11).

4. Error Codes (D106= 1, error; see Table 2-14)

5. Data Codes (D106-0, nonerror; see Table 2-15)

## 2.30 MACHINE STATUS (Secondary Addresses c and d)

The Model 619 can be addressed to give its current machine status. To get the current status of Channel A, send (Talk Address) secondary address c. To get the current status of Channel B, send (Talk Address) secondary address d. Figure 2-12 and Table 2-16 and 2-17 define each byte of information. Q0 must be in effect when reading machine status.

### NOTE

If SRQ is not read within 100ms after "SPE and Talk address," the Model 619 resets to default conditions.

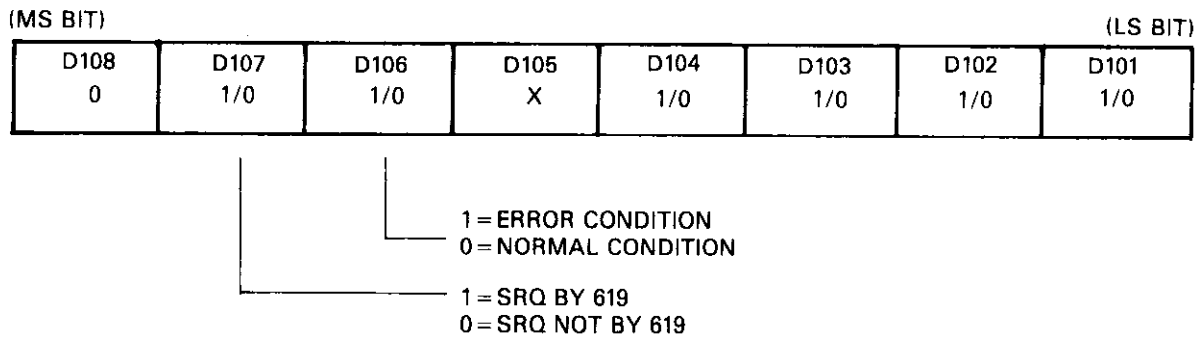

**Figure 2-11. Status Byte**

**Machine Status Ch. A (Secondary Address 63<sub>11</sub>)**

0	+1	+2	+3	+4	+5	+6	+7	+8	+9	+10	+11	+12	+13	+14	+15
ZERO CORRECT	FILTER	ZERO CHECK	FUNCTION	RANGE	MODE	RATE TYPE	0	TRIGGER	BASELINE STORE	BASELINE SUPPRESS	AUTO RANGE	INT PERIOD	TERMINATOR	50/60 Hz	#READINGS TO AVE
Z	P	C	F	R	M	S	D	T	N	U			Y		

**Machine Status Ch. B (Secondary Address 64<sub>11</sub>)**

0	+1	+2	+3	+4	+5	+6	+7	+8	+9	+10	+11	+12	+13	+14	+15
ZERO CORRECT	FILTER	ZERO CHECK	FUNCTION	RANGE	MODE	RATE TYPE	DATA	TRIGGER	BASELINE STORE	BASELINE SUPPRESS	AUTO RANGE	INT PERIOD	TERMINATOR	0	#READINGS TO AVE
Z	P	C	F	R	M	S	D	T	N	U			Y	Q	

For example, after power on, Channel A status would read in 60Hz operation in ASCII: 0010403000004 02 In 50Hz operation: 0010403003008 72

**Figure 2-12. Machine Status**

**Table 2-14. Error Codes**

*Hex Code	Meaning	Display
0	ILLEGAL DEVICE DEPENDENT Command	IddC
1	ILLEGAL DEVICE DEPENDENT Command Option	IddCO
2	Attempt to PROGRAM when not in remote	no rn
3	No zero check with 2 AMP	no 2AC
4	No zero check with zero correct	Corr II.
5	Spare	no Au
6	No autoranging in this range	
7	Spare	
8	Invalid string with baseline store	ISbS

\*D104 through D101

**NOTE**

Data Codes (0106-0, nonerror) (see Table 2-16).

**Table 2-15. Data Codes**

*Hex Code	Meaning	Display
0	Normal	--
1	OVERFLOW	OFLO
2	DIFFERENCE	--
4	RATIO	--
5	Buffer Full	--

\*D104 through D101

**Table 2-16. Byte Definitions**

<p>Byte 0 Zero Correct</p> <p>chA: 0 = Zero Correct off (Z0) 1 = Zero Correct on (Z1)</p> <p>chB: Same as chA</p>	<p>Byte 1 Filter</p> <p>chA: 0 = Filter off (P0) 1 = Filter on (P1)</p> <p>chB: Same as chA</p>
<p>Byte 2 Zero Check</p> <p>chA: 0 = Zero Check off (C0) 1 = Zero Check on (C1)</p> <p>ch B: Same as chA</p>	<p>Byte 3 Function</p> <p>chA: 0 = Volts (F0) 1 = Amps (F1) 2 = Ohms (F2)</p> <p>chB: Same as chA</p>
<p>Byte 4 Range</p> <p>chA: 0 = Autorange 1 = Range 1 (R1) 2 = Range 2 (R2) 3 = Range 3 (R3) 4 = Range 4 (R4) 5 = Range 5 (R5) 6 = Range 6 (R6) 7 = Range 7 (R7) 8 = Range 8 (R8) 9 = Range 9 (R9) : = Range 10(R:)</p> <p>chB: Same as chA</p>	<p>Byte 5 Mode</p> <p>chA: 0 = Non SRQ (M0) 1 = SRQ (M1)</p> <p>chB: Same as chA</p>
<p>Byte 6 Rate Type</p> <p>chA: 0 = Rate (S0) 1 = Rate (S1) 2 = Rate (S2) 3 = Rate (S3) 4 = Rate (S4) 5 = Rate (S5) 6 = Rate (S6) 7 = Rate (S7) 8 = Rate (S8) 9 = Rate (S9)</p>	<p>Byte 7 Data</p> <p>chA: 0 = ASCII (D0) 1 = Binary (D1)</p> <p>chB: Same as chA</p>

chB: Same as chA

**Table 2-16. Byte Definitions (Cont.)**

<p>Byte 8 Trigger</p>	<p>Byte 9 Baseline Store</p>
<p>chA: 0 = Continuous on Talk (T0)          1 = One-Shot on Talk (T1)          2 = Continuous on Get (T2)          3 = One-Shot on Get (T3)          4 = Continuous on X (T4)          5 = One-Shot on X (T5)</p> <p>chB: Same as chA</p>	<p>chA: 0 = No Store (N0)          1 = Store Reading (N1)</p> <p>chB: Same as chA</p>
<p>Byte 10 Baseline Suppress</p>	<p>Byte 11 Auto Range</p>
<p>chA: 0 = Suppress off (U0)          1 = Suppress on (U1)</p> <p>chB: Same as chA</p>	<p>chA: 0 = Non-Autorange          7 = Autorange</p> <p>chB: Same as chA</p>
<p>Byte 12 Int Period</p> <p>chA: 4 = 16.66ms          5 = 4.1ms          8 = 20ms          8 = 100ms</p> <p>chB: Same as chA</p>	<p>Byte 13 Terminator</p> <p>ch A ? = Y (DEL)          = = Y (CR)          : = Y (LF)</p> <p>chB: Same as chA</p>
<p>Byte 14</p>	<p>Byte 15 No. Readings to Ave.</p>
<p>chA: 50/60Hz          0 = 60Hz          ? = 50Hz</p> <p>chB: Buffer State          1 = Buffer no readings (Q0)          : = Buffer 10 readings (Q1)          4 = Buffer 20 readings (Q2)          &gt; = Buffer 30 readings (Q3)          8 = Buffer 40 readings (Q4)          2 = Buffer 50 readings (Q5)</p>	<p>chA: 0 = 1          1 = 2          2 = 4          3 = 8          4 = 16          5 = 32</p> <p>chB: Same as chA</p>

## SECTION 3 ACCESSORIES

### 3.1 INTRODUCTION

Section 3 lists the optional modules and accessories available for installation in, or use with, the Model 619 Electrometer/Multimeter.

### 3.2 MODEL 6191 GUARDED ADAPTER

The Model 6191 Adapter is an outboard option for use with the Model 6194 Electrometer Module. It reduces effective cable capacity by driving the inner shield of triaxial cable at guard potential and thereby reduces time constants due to high source resistances when measuring volts and ohms. By reducing the additional effective cable capacitance to approximately 2pF, it permits measurements from high impedance sources. (See Figure 3-1.)

The Adapter OUTPUT connects directly to the Model 6194 Electrometer Module INPUT shielded connector. Guard potential is obtained from the Model 6194 Analog Output.

The Adapter's INPUT is connected to the measurement. The unit is switch selectable for guarded or unguarded operation. In the guarded mode of operation the outside conductor of the input connector is at input common as opposed to power line ground for the "unguarded" mode.

Note that the Adapter will reduce the input common mode voltage to a maximum of 30V RMS at DC to 60Hz. Also, a  $10^7\Omega$  isolation resistance can be placed in series with the input by removal of an internal jumper. This is for use in measurement of voltage sources which cannot tolerate the Model 6194's 500k $\Omega$  input impedance in "zero check" operation.

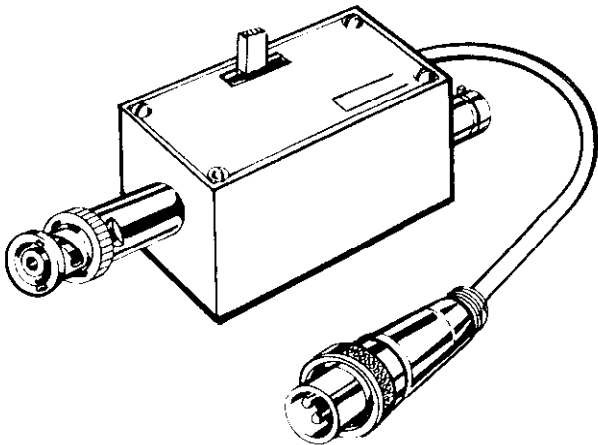

Figure 3-1. Model 6191 Guarded Adapter

### 3.3 MODEL 6193 IEEE STANDARD 488 OUTPUT

The Model 6193 is an IEEE Standard 488 Bus Interface. It permits the Model 619 to interface with any measurement system utilizing the IEEE Standard Bus. The primary 5-bit address is selected by five switches on the rear panel of the Model 6193. This allows the selection of 31 primary listen or talk address pairs. Binary 31 (11111) is reserved for the Un-talk and Unlisten commands. The five rear panel switches are set at the factory for a primary address of binary 6 (00110). The literature pertaining to the Model 6193 assumes that binary 6 is the primary address. (See Figure 3-2.)

Interface specifications (including line commands, parameters and response time) are provided in the detailed specifications which precede Section 1. Address modes or Addressable (ADDR) or Talk Only are also switchable on the rear panel of the Model 6193 module.

The Model 6193 was designed to be an interrupt driven I/O device. The board uses the Motorola 68488 IEEE chip which is capable of performing all IEEE Talker/Listener protocols. Along with the 68488 IEEE chip, it also contains Motorola 3448A IEEE bus transceivers, which are capable of driving and/or terminating the IEEE bus lines per the IEEE specifications. See Model 7008 IEEE-488 Digital Cable (paragraph 3.7) for cable interconnect.

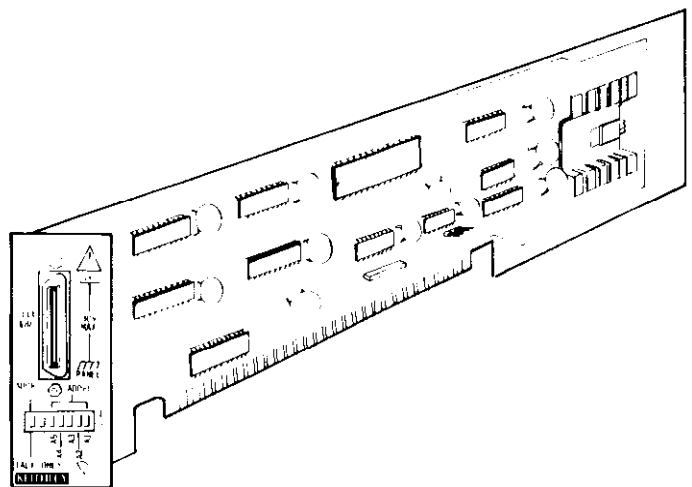

Figure 3-2. Model 6193 IEEE Standard 488 Output

### 3.4 Model 6194 Electrometer Module

The Model 6194 is an Electrometer Module that has three functions - Volts, Ohms and Amps. It is an input module for the Model 619 Electrometer/Multimeter. Addition of a second Model 6194 provides dual channel capability with independent ranges and functions as well as ratio and difference capabilities. (See Figure 3-3.)

The Module structure consists of two printed circuit boards mounted on a common rear panel. The inputs and analog output of the Model 6194 are located on its rear panel. The power and control inputs are obtained through the Model PC edge connectors plugged into the Model 619.

All Model 6194 Electrometer Module functions and ranges are programmed over the analog bus. Converted into its various measurement configurations, the Model 6194 Electrometer Module processes an input measurement to a 200mV or 2V signal which is in turn processed further by the A/D Converter module and the Filter/Mux module.

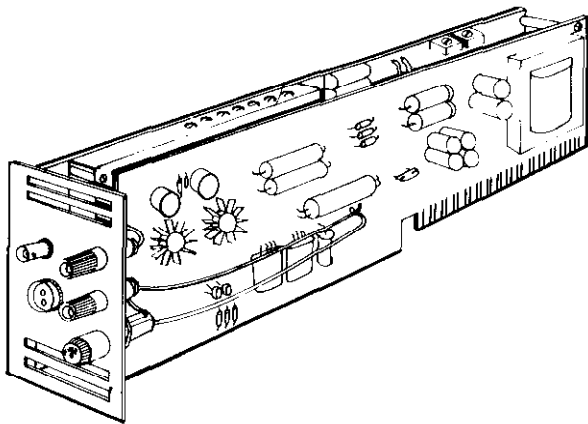

Figure 3-3. Model 6194 Electrometer Module

### 3.5 MODEL 6195 MAINTENANCE KIT

The Model 6195 is a maintenance kit for the Model 619. The calibration cover is installed in place of the normal Model 619 top cover during calibration. It allows the Model 619 to reach normal internal operating temperature and has

adjustment openings that are marked to facilitate making the calibration alignments. (See Figure 3-4). The extender cards allow easy access to the individual board for troubleshooting purposes.

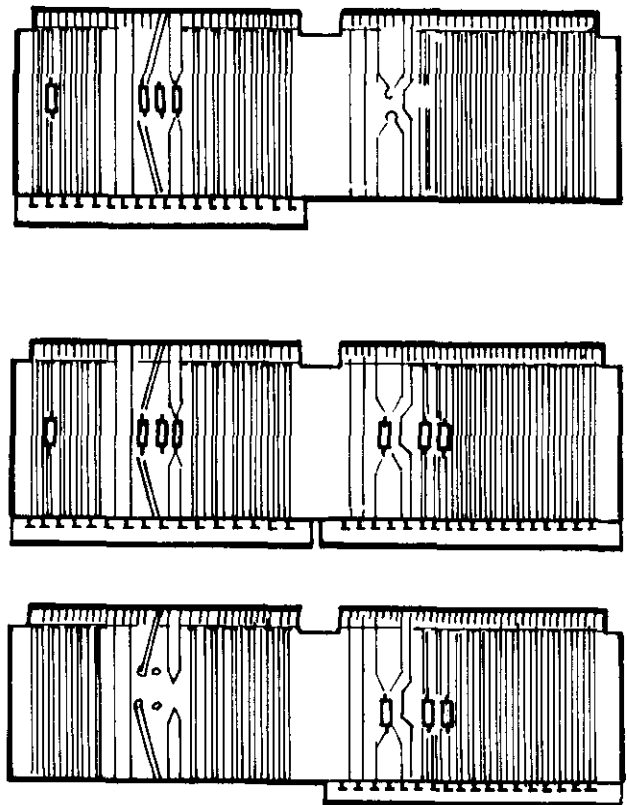
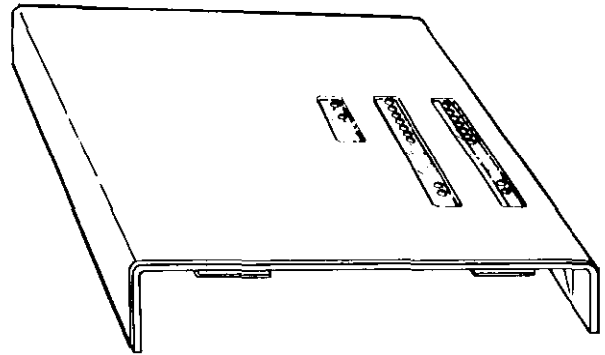

Figure 3-4. Model 6195 Maintenance Kit



### 3.6 MODEL 6199 RACK MOUNTING KIT WITH CHASSIS SLIDES

The Model 6199 is a rack mounting kit for the Model 619. It provides the necessary hardware to mount the Model 619 in a 5 1/2 inch (140 millimeter) rack height. The chassis slide permits the unit to be pulled forward, the top cover removed, and internal adjustments or changes in configuration to be made. (See Figure 3-5.)

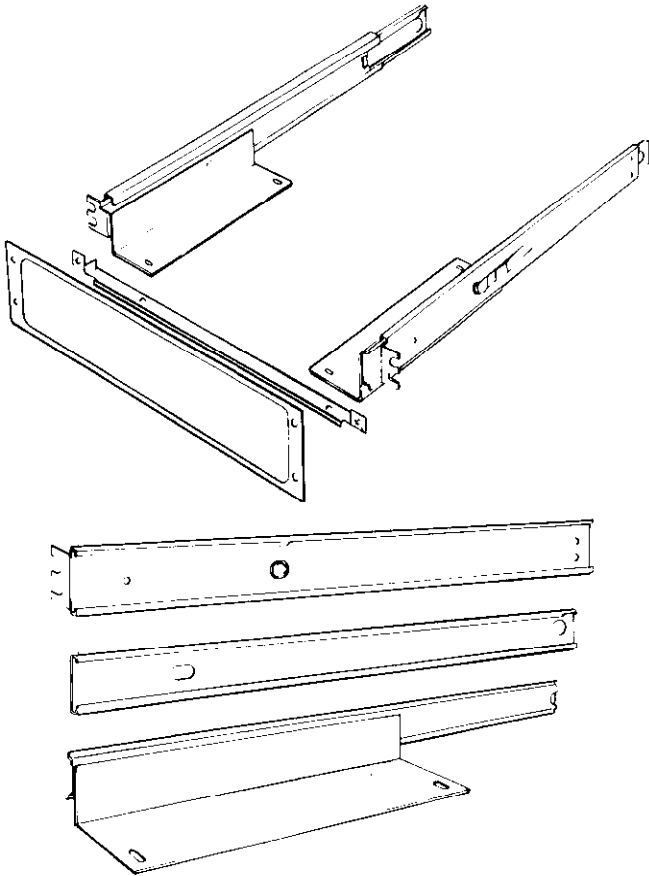

Figure 3-5. Model 6199 Rack Mounting Kit with Chassis Slides

### 3.7 MODEL 7008 IEEE-488 DIGITAL CABLE

The Model 7008 is a six foot (two meter) IEEE-488 digital cable. The cable has 24 stranded wire conductors and is terminated with IEEE Standard 488 connectors. This will connect the Model 6193 to any IEEE Standard 488 connectors.

### 3.8 MODEL 6011 TRIAX INPUT CABLE

The Model 6011 is a four foot (1 1/2 meter) low noise triax cable terminated with alligator clips at one end and a triax connector at the other end. This is a supplied accessory with the Model 6194 Electrometer Module. (See Figure 3-6.)

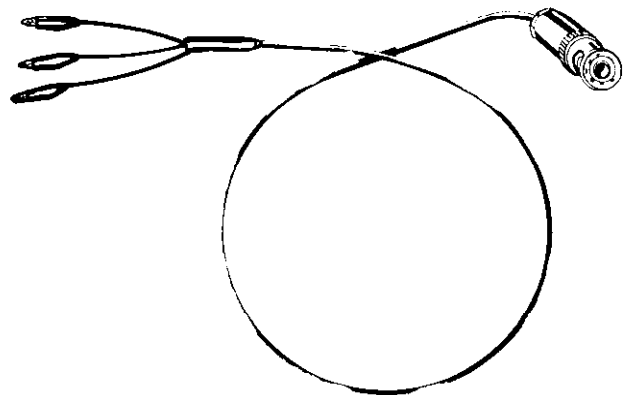

Figure 3-6. Model 6011 Triax Input Cable

## SECTION 4

# PERFORMANCE VERIFICATION

### 4.1 INTRODUCTION

Performance verification is recommended upon receipt of the instrument, to ensure that no damage or misadjustment has occurred during transit. Verification may also be performed whenever the instrument's accuracy is questioned or following calibration.

#### NOTE

For instruments that are still under warranty (less than 12 months since date of shipment), and whose performance falls outside specifications at any point, contact your Keithley representative or the factory immediately.

#### 4.1.1 Required Test Equipment

The accuracy of the test equipment should be at least five times better than the instrument specifications. The minimum required accuracy ratings of the voltage, current, and resistance sources are as follows:

1. Voltage sources:
  - A. 190mV to 1.9V - .002%
  - B. 19V to 190V - .003%
2. Current sources:
  - A. 1.9nA to 19nA - .07%
  - B. 190nA to 1.9A - .03%
3. Resistance sources:
  - A. 1.9k $\Omega$  to 19k $\Omega$  - .04%
  - B. 190k $\Omega$  to 1.9M $\Omega$  - .03%
  - C. 19M $\Omega$ , 190M $\Omega$ , 1.9G $\Omega$  - .07%
  - D. 19G $\Omega$  - .2%
  - E. 190G $\Omega$  - .8%
  - F. 1.5T $\Omega$  - 2%

If the accuracy of the test equipment is not at least five times better than the instrument specifications, additional allowance must be made in the readings obtained.

#### 4.1.2 Environmental Conditions

All measurements should be made at an ambient temperature within the range of 18° to 28°C (65° to 82°F) and a relative humidity of less than 70%.

### 4.2 MODEL 619 PERFORMANCE VERIFICATION

Use the following procedures to verify the basic accuracy of the Model 619. If the instrument is out of specification at any point, a complete calibration may be performed as

described in Section 6. However, if the instrument is still under warranty, contact your Keithley representative or the factory immediately.

#### NOTE

Performance verification should be performed by qualified personnel using accurate test equipment with current calibration and traceability.

#### 4.2.1 Initial Conditions

Before beginning the verification procedure the instrument must meet the following conditions:

1. If the instrument has been subjected to extremes of temperature, allow sufficient time for internal temperature to reach normal operating environmental conditions specified in paragraph 4.1.3. Typically, it takes one hour to stabilize a unit that is 10°C (18°F) out of the specified temperature range.
2. Turn on the Model 619 and allow it to warm up for one hour.

#### WARNING

**Some procedures require the use of high voltage. Take care to prevent contact with high potential circuits which could cause electrical shock resulting in injury or death.**

#### 4.2.2 Voltage Verification

1. Place the instrument in Zero Check, Channel A, Volts, and Manual ranging.
2. Set the Model 619 to the 200mV range and apply +190.00mV to the Channel A input. Zero correct the instrument and verify a display reading of 0.00 -3 to within  $\pm 1$  count.
3. Release the Zero Check and verify a display reading of +190.00 -3 to within  $\pm 6$  counts.
4. Repeat steps 1 through 3 using negative voltage.
5. Refer to Table 4-1 and repeat the above procedures for the remaining voltage ranges.
6. If an Electrometer is installed in Channel B, repeat steps 1 through 5 for that channel.

#### 4.2.3 Current Verification

1. Place the instrument in Zero Check, Channel A, Amps, and Manual ranging.

2. Set the Model 619 to the 2nA range and apply 1.9000nA to the Channel A input. Zero correct the display if necessary.
3. Release the Zero Check and verify a display reading of 1.9000 -9 within  $\pm 59$  counts.
4. Refer to Table 4-2 and repeat the above procedures for the remaining current ranges.
5. If an Electrometer is also installed in Channel B, repeat steps 1 through 4 for that channel.

**NOTE**

For the 200 $\mu$ A through 20mA ranges, for valid zero correction, input current must be no greater than 100 $\mu$ A. Zero correction does not apply to the 2A range.

**Table 4-1. DC Voltage Performance Check**

Range	Applied Voltage	Allowable Readings at 18° to 28°C	*
200mV	190.00mV	189.94 to 190.06	-3
2V	1.9000V	1.8997 to 1.9003	+0
20V	19.000V	18.996 to 19.004	+0
200	190.00V	189.96 to 190.04	+0

\*These display readings take into account the errors that may be generated using the input sources listed in paragraph 4.1.2.

**4.2.4 Resistance Verification**

1. Place the instrument in Zero Check, Channel A, Ohms, and Manual ranging.
2. Set the Model 619 to 2k $\Omega$  and apply 1.9000k $\Omega$  to the input of Channel A. Zero Correct the display if necessary.
3. Release the Zero Check and verify a display reading of 1.9000 +3 within  $\pm 34$  counts.
4. Refer to Table 4-3 and repeat the above procedures for the remaining resistance ranges.
5. If an Electrometer is also installed in Channel B, repeat steps 1 through 4 for that channel.
6. For ohms sources above 200k $\Omega$ , the resistance element should be shielded to prevent noise pickup. Refer to Figure 4-1.

7. For ohms sources greater than 200M $\Omega$  the resistance should be both guarded and shielded. The shield prevents noise injection into the measurement and the guard reduces response settling times (see Figure 4-2). This can also be accomplished by using Model 6191 Guarded Adapter (see Figure 4-3).

**Table 4-2. DC Current Performance Check**

Range	Applied Current	Allowable Readings at 18° to 28°C	*
2nA	1.9000nA	1.8941 to 1.9059	-9
20nA	19.000nA	18.943 to 19.057	-9
200nA	190.00nA	189.73 to 190.27	-9
2 $\mu$ A	1.9000 $\mu$ A	1.8976 to 1.9024	-6
20 $\mu$ A	19.000 $\mu$ A	18.973 to 19.027	-6
200 $\mu$ A	190.00 $\mu$ A	189.76 to 190.24	-6
2mA	1.9000mA	1.8973 to 1.9027	-3
20mA	19.000mA	18.976 to 19.024	-3
2A	1.9000A	1.8973 to 1.9027**	+0

\*These display readings take into account the possible errors that may generated using the input sources listed in paragraph 4.1.2.

\*\*When using the 2A range, the input must be applied to the terminals designated as 2 AMPS MAX INPUT.

**Table 4-3. Ohms Reference Check**

Range	Applied Resistance	Allowable Readings at 18° to 28°C	*
2k $\Omega$	1.9000k $\Omega$	1.8966 to 1.9034	+3
20k $\Omega$	19.000k $\Omega$	18.969 to 19.031	+3
200k $\Omega$	190.00k $\Omega$	189.73 to 190.27	+3
2M $\Omega$	1.9000M $\Omega$	1.8976 to 1.9024	+6
20M $\Omega$	19.000M $\Omega$	18.943 to 190.57	+6
200M $\Omega$	190.00M $\Omega$	189.46 to 190.54	+6
2G $\Omega$	1.9000G $\Omega$	1.8946 to 1.9054	+9
20G $\Omega$	19.000G $\Omega$	18.847 to 1.9153	+9
200G $\Omega$	190.00G $\Omega$	183.91 to 196.09	+9
2T $\Omega$	1.5000T $\Omega$	1.3800 to 1.6200	+12

\*These display readings take into account the errors that may be generated using the input sources listed in paragraph 4.1.2.

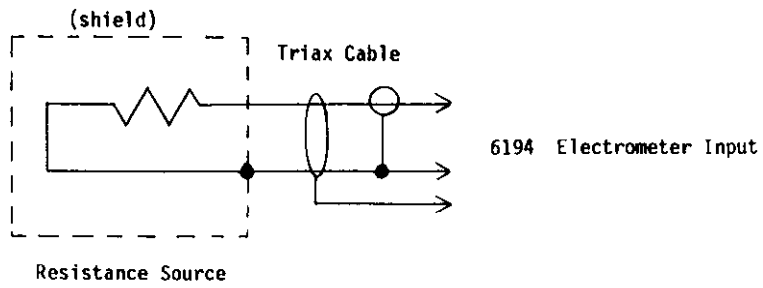

**Figure 4-1. Resistance Source Shielding**

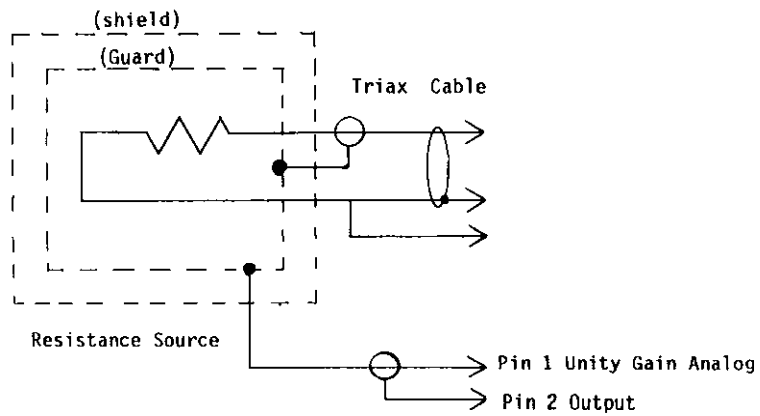

**Figure 4-2. Resistance Source Shielding and Guarding**

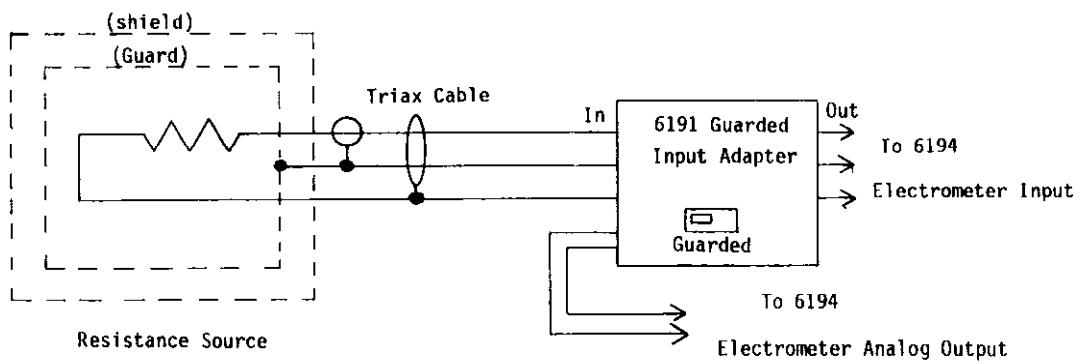

**Figure 4-3. Measuring Resistance Sources Using Model 6191**

## SECTION 5 THEORY OF OPERATION

### 5.1 INTRODUCTION

This section contains functional and circuit descriptions of the component parts of the Model 619 and its related modules and options. The following components are included:

- Power Supply, PC-515
- Electrometer Module, PC-522 and PC-523
- IEEE-488 Interface, PC-517
- CPU, PC-518
- Display/Keyboard, PC-514
- A/D Converter, PC-520
- Filter/Multiplexer, PC-521

The Model 619 is a versatile Electrometer/Multimeter intended for use independently or with programmed test and measurement systems. Current sensitivity and input impedance meet or exceed practical limits for most applications. Figure 5-1 provides an overall operational view. Section 7 contains schematic diagrams to aid in understanding circuit operation.

### 5.2 POWER SUPPLY

The Power Supply, shown in Figure 5-2, is mounted on the cabinet left side (as viewed from the front) and consists of a PC board, Shield (30450), and Rear Panel (30448). The Rear Panel contains the line fuse, line cord plug, and a series ON/OFF switch (S303). Refer to Schematic Diagram 30516 and 32004 in Section 7.

AC power is provided to the Model 619 by the line plug/filter, P301. Transformer 301 and the fan receive power through the series circuit of fuse F301, and switches S303 and S304. F301 and S303 are located on the rear panel of the power supply. Switch S304, mounted on the instrument front panel, is connected to the power supply through R303. The AC power is also applied to the transformer, T301, through switches S301 and S302. These switches permit transformer operation in four AC line voltage ranges (refer to Table 5-1). The vent fan is powered from the transformer primary through connector P302. T301 acts as an autotransformer, setting the voltage level to the fan.

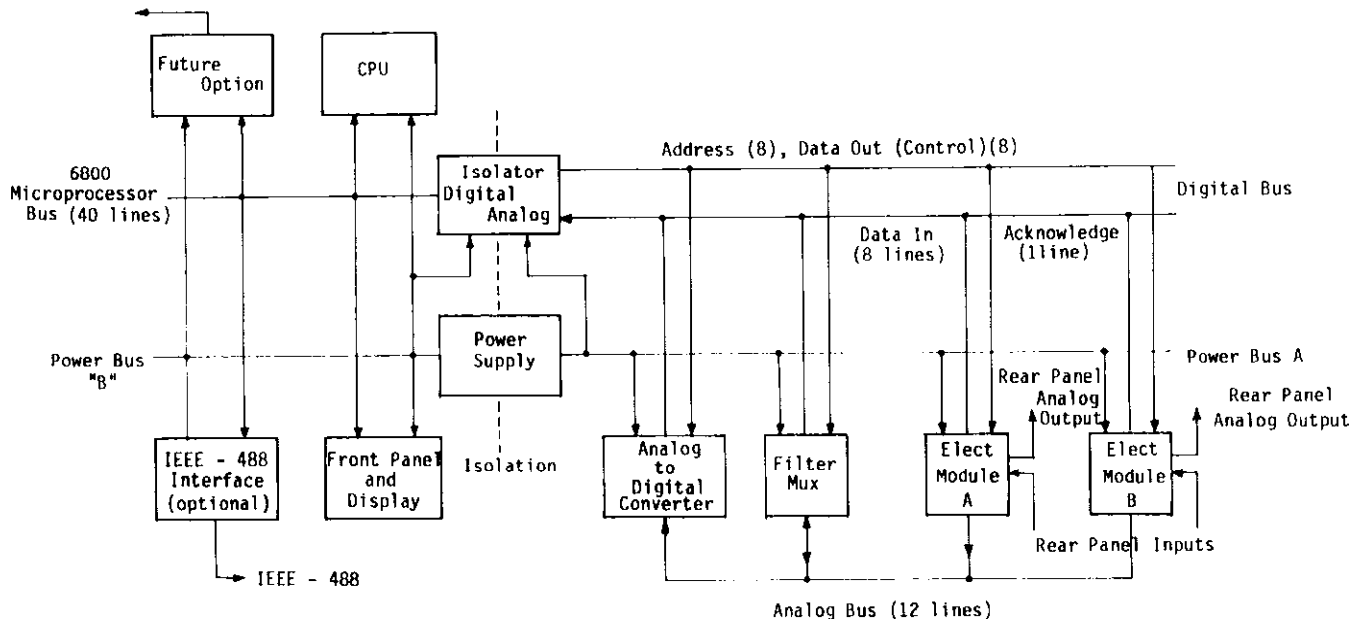

**Figure 5-1. Model 619 Block Diagram**

The transformer secondaries are grouped to provide power to the Model 619 digital and analog buses. The digital portion, which provides +9.5V unregulated, consists of a bridge rectifier CR301, filter capacitors C302 and C303, bleeder resistor R302, and a parallel network consisting of R301 and C301. The R301 and C301 network makes digital common electrically equal to power line (chassis) ground. The unregulated DC voltage developed is connected to the mother board digital bus J304.

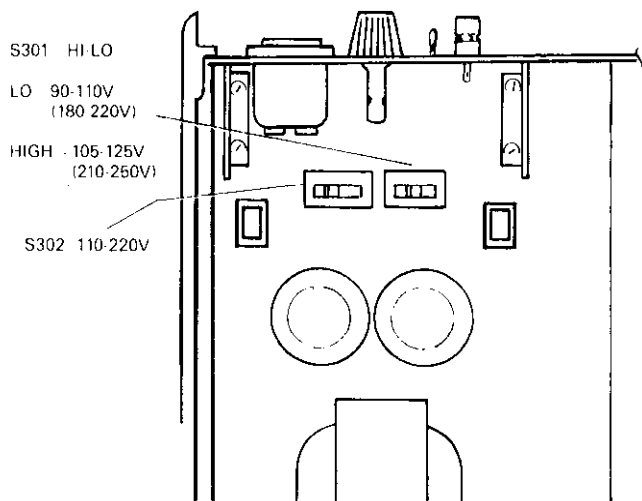

**Figure 5-2. Power Supply**

The analog portion consists of bridge rectifiers CR303 and CR302, filter capacitors C304 through C312, voltage regulators VR301 through VR303 and voltage bleeder resistors R303 through R305. The AC power, 33VAC, that is used by the Electrometer modules, is obtained from the winding that powers the  $\pm 15$ VDC rectifier, filter, and regulator portions of this circuitry. The regulated voltage potentials, of +5VDC and  $\pm 15$ VDC are provided to the mother board analog bus through connector J305.

### 5.3 MODEL 6194 ELECTROMETER MODULE

The Electrometer Module is a three-function component (volts, ohms, and amps). The module construction consists of two PCB's mounted together with a common rear panel. All of the module functions and ranges are programmed over the analog bus. In its various measurement configurations, the module processes an input measurement to an output of 200mV, or 2V, which is further processed by the A/D Converter and Filter/Multiplexer.

A Model 619 instrument may contain one or two Model

6194 Electrometer Modules. When two are installed, the one on the left (as viewed from the rear) is Channel A. The second Model 6194 is Channel B. Figure 5-3 provides an overall view of the Electrometer Module.

The heart of the design is a bootstrapped op-amp with an ultra-low input bias current. The input overload protection is provided by a ballast resistance and by current limiting on the bootstrapped output. This circuit can be arranged in two versions.

1. In Amps the circuit is arranged as a current to voltage converter. Various feedback resistances are used to measure a wide range of input currents.
2. The circuit can also be arranged as a high input impedance unity-gain buffer which is utilized for both volts and ohms measurements. When in the Ohms configuration, a constant current source consisting of a bootstrapped voltage reference and various feedback resistances is used to convert an unknown resistance to a measurable voltage level.

The input to the module is via a triax connector. Separate binding posts and a microphone connector are provided for the 2 Amp current range and analog output respectively. All input/output connections, along with a fuse, are located on the rear panel of the module. A calibrated resistive divider couples the module output to the input of an A/D Converter at 200mV and 2V.

Power is supplied to the module via a transformer isolated, floating power supply. The logic for decoding and latching system commands to the Electrometer module are shown in the block diagram in Figure 5-3.

#### 5.3.1 Theory of Operation for the Model 6194 Electrometer Module

##### NOTE

When reading through the theory of operation for the Electrometer Module, refer to Schematic Diagrams 30522D and 30523D, located in Section 7.

The Power and Control inputs are obtained by plugging the module P-C edge connectors into the appropriate connectors on the Model 619 mother board (PC-516). This connector ties the module to the analog bus. Tables 5-5 and 5-6 are the pin assignments for Channel A and B Electrometers respectively. The input module identity is wired into the mother board by transposing address lines A0 and A1 between Channel A and Channel B locations on the mother board.

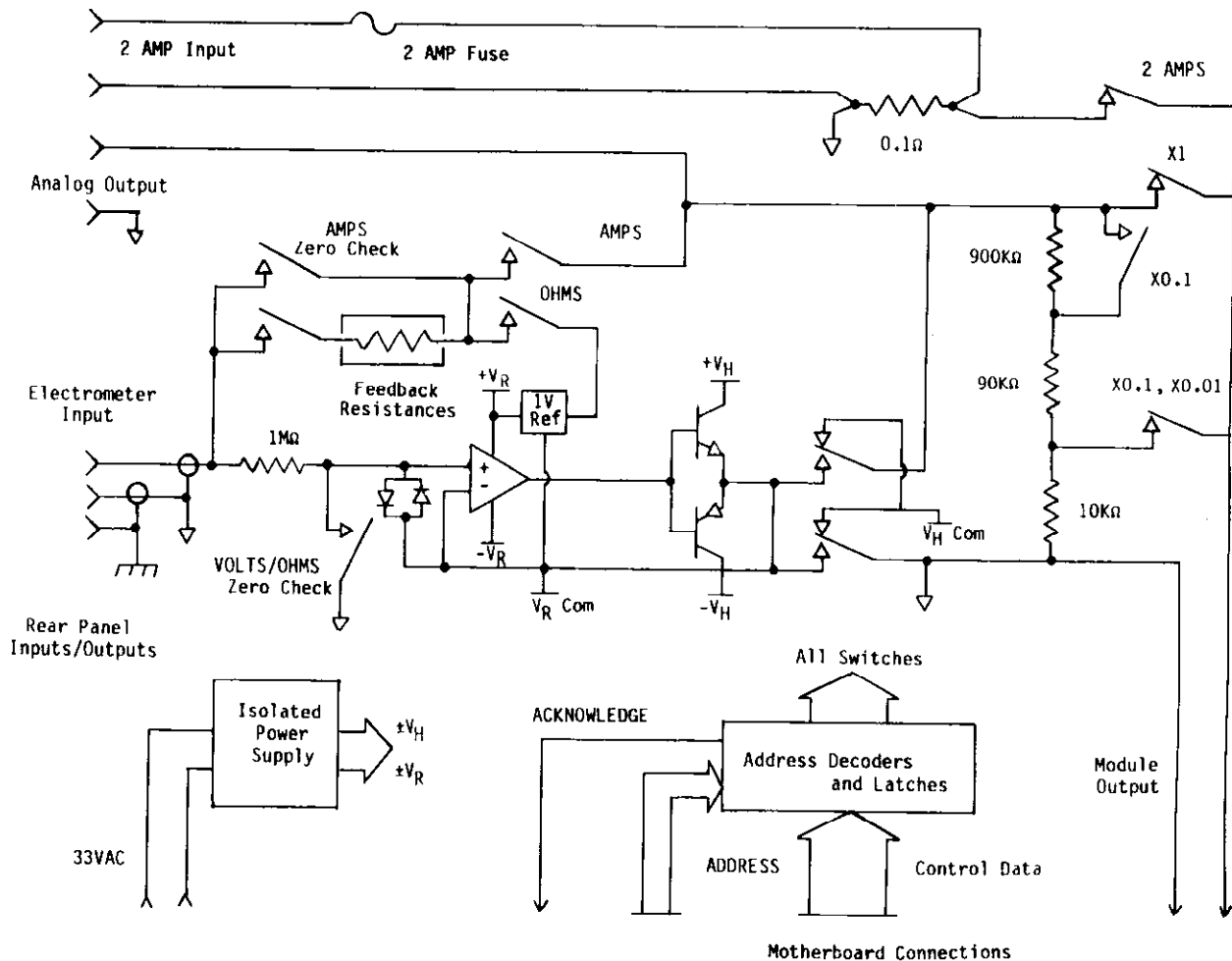

Figure 5-3. Electrometer Module Block Diagram

PC-522 (30522D) contains the module power supply, output circuitry and 1 Amp current range shunt. The power supply portion of the circuitry provides three basic voltage levels for the module. It provides  $\pm 260\text{VDC}$  (TP-1 and TP-2 to input common) which is used by the output circuitry when configured in the Volts or Ohms functions. It also provides  $\pm 8\text{VDC}$  (TP-3 and TP-4 to TP-6) for use by the output circuitry when configured in the Amps function. This also eliminates the necessity of the  $\pm 260\text{V}$  supply having to supply greater than 2mA. The  $\pm 17\text{VDC}$  (TP-7 and TP-8 to TP-9) bootstrapped supply is used by the input amplifier and ohms reference on 30523D. The transformer (T601) in addition to providing the various voltage levels, serves to isolate the module from other instrument voltage sources.

The center of the output circuitry is a bipolar totem pole arrangement consisting of high voltage transistors Q601, Q603, Q604, and Q602. Resistors R601, R606, R608, and R602 bias their respective transistors to ensure that the voltage burden is equally divided between the two transistors at each end of the network. The network is current

biased by the voltage developed across CR615 through CR618. CR615 through CR618 are essentially connected across the totem pole arrangement. In the Amps function, the contacts B and C of relay K602 short out R615 and R617. This action increases the bias current level. The bipolar networks consisting of Q605, Q606, CR620, CR619, R613, and R615, limit the output current ranges. The top ends of the high voltage "totem pole," which are disconnected by contacts A and B of relay K601, prevent excessive power from getting to this particular portion of the circuitry. In this mode, input is supplied to Q603 and Q604 through CR605 and CR608. Capacitor C605 serves as response stabilization in the Amps configuration. CR605 through CR608 have an additional function in disconnecting the  $\pm 8\text{VDC}$  supply (TP-3 and TP-4 to TP-6) from the circuit when it is in the Volts or Ohms functions. CR602 and CR604 disconnect the entire output circuit from the  $\pm 260\text{VDC}$  supply during input voltage overload in either volts or ohms. The drive to the output circuit is provided by the bootstrapped amplifier U651 on PC-523 and via Pin 56 on the intramodule bus.

R607, R609, CR613, and CR614 provide extra drive current to Q601 and Q602 when the circuit is operating near the  $\pm 260\text{V}$  supply voltage levels. CR601 and CR603 protect the emitter-base junctions of transistors Q601 and Q602 from reverse voltage bias.

Controlling the configuration of the output circuitry are the relays K601 and K602. These two relays are actuated by R611, R610, Q607, and Q608 along with commutation diodes CR623 and CR622. Control is provided via Pin 52 on the intramodule bus from logic decoders on PC-523. K601 sets up the output for both Volts and Ohms functions providing for a non-inverting gain. K602 sets up the output for the Amps function by providing for an inverting gain conversion.

The remaining circuitry on PC-522 includes the 2 Amp current range shunt resistance, R605. The 2 Amp range has separate binding post inputs, J601 and J602, and fuse protection F601. Relay K603 along with commutation diode CR621 selects this range for connection to the module output. Control is provided from logic decoders on PC-523 via Pin 52 on the intramodule bus. Fuse F601 provides overload protection and is mounted for access on the rear panel of the module.

The rest of the Electrometer module circuitry is located on PC-523. The circuitry includes the following:

- Input Amplifier
- Feedback Networks
- Ohms Reference
- Bootstrapped Power Supply Regulators
- Module Output Attenuator
- Control Logic Decoders.

The input amplifier consists of a group of components: R664, R665, R668, R667, R669, R656, C651, C658, C661, K656, and U651. The heart of this section of the circuit is the Electrometer operational amplifier, U651. Providing the active forward gain portion of the Electrometer module, this circuitry is combined with the feedback networks and bootstrapped ohms voltage reference to provide amps and ohms along with the basic volts measurements.

Potentiometer R656 is used to trim the input offset voltage for U651 while R667 and C661 provide a pole/zero stabilization to this forward gain block of the module. R669 is the pull-up resistor for the output circuitry on PC-522. R668 provides the input protection for U651 by limiting the input current. C658 (along with R668) provides input stabilization on Volts and Ohms functions. Relay K656 is the zero check contact with R665 limiting the zero check input current. R664 and C651 provide compensation for this extra input resistance in the Amps function.

Five feedback networks are used in setting up the Electrometer module for both the Amps and Ohms functions. Utilizing the inverting mode of the module output circuitry a current to voltage converter is obtained.

A bootstrapped voltage reference develops a constant current source for use with the non-inverting module output circuitry mode, for ohms measurements. The five networks used are 100 ohms (R601, R607), 10kohms (R659, R652), 1Mohm (R660, R653), 100Mohms (R662, R654), and 10Gohms (R663, R655, R666). Potentiometers R651 through R655 permit calibration of five networks. Capacitors C652, C653, C656, C655, and C657 stabilize the feedback response. Resistors R661 and R688 protect relay contact K657 from momentary current surges when capacitors C653 and C656 are connected together. Connection of the proper feedback network into the circuit is made by high isolation impedance relays K651 through K654 and normal isolation impedance relay K657. High isolation impedance relay K655 provides a low resistance feedback network which is used for amps zero check. Connection to the input by relay K655 is made after R665, to limit the effect of the real contact resistance on the measured zero offset.

The ohms voltage reference consists of K658, K659, VR653, U653, R676, R675, R672, R673, R670, R657, and C662. The voltage reference is obtained from VR652; scaled by R670, R672, and R673; and calibrated by R657. Op amp U653 buffers the scaled voltage across R670 providing a low output impedance to the feedback networks. C662 and R675 serve to frequency compensate U653. R676 limits the overload current on the output of U653. When VR653 is switched in by relay K659, it limits the voltage across the resistance being measured. The connection of the ohms reference to the feedback networks is made via relay K658.

Power to ohms reference and the input amplifier is provided by the power supply circuitry which consists of U652, VR651, VR652, R674, R677, R671, C654, C659, and C660. These bipolar voltage supplies are bootstrapped to the Electrometer module output in the volts and ohms configurations. The negative voltage (-VR) is provided by regulator VR651. Positive voltage (+VR) is provided by U652 which amplifies the reference zener (VR652) voltage. Capacitors C654, C659, and C660 provide the transient response protection.

The parallel combination of R687 and C665 serves to limit output current from U651 preventing excessive current draw from U652 and subsequent latch up of the input circuitry.

The module output attenuator provides a 2 Volt full scale output to the A/D Converter for those ranges and functions which result in a 20V or 200V full scale analog output. This portion of the circuitry consists of R679 through R683 and relays K660 through K662. As mentioned previously, the A/D Converter has two ranges of operation, 2V and 200mV full scale. Potentiometers R679 and R680 calibrate the two attenuation gains of 0.1 and 0.01. Relays K660 through K662 select either the unscaled module output (K661) or the output attenuator (K662)  $\times 0.01$  or  $\times 0.1$  (K660).



Resistors R686 and R678 are included to protect the Electrometer module circuitry. Resistor R678 protects the module from imposing a voltage potential from analog output (J652) common to module input (J651) common. Resistor R686 protects the module from transient voltage input from the module output connection in the analog bus.

The remaining portion of the Model 6194 Electrometer circuitry is the Control Logic Decoder. This portion of the module consists of U654 through U658, Q651, R685, C664, and commutation diodes CR652 through CR663 and CR664. U654 and U655 are octal D-type transparent latches which store the appropriate data from control data inputs and drive the module configuration relays. Data is clocked in by decoding the module address through U656A and B. Controlling the module requires "Function Byte" (U654) and a "Range Byte" (U655) which are latched with the appropriate address. These addresses and function/range bytes are listed in Table 5-7. The identification or control performed by each data bit in the function/range bytes is listed in Table 5-8.

An acknowledge circuit, which consists of U656, R684, and Q651, provides output to a wired NOR control line on the "Analog Bus." This serves to acknowledge the receipt of a proper address by the module.

The section of circuitry consisting of U657C and D, R685, CR664, and C664 performs a power up disable function. The output of both latches U654 and U655 will be disabled upon power up until receipt of a proper module function-byte address. This prevents a random (and erroneous) configuration of the Electrometer module by power up transients. Additional logic prevents erroneous, simultaneous actuation of relays which could result in damage to the module.

Capacitors C666 through C668 prevent noise pickup and subsequent erroneous relay actuation.

#### 5.4 MODEL 6193 IEEE-488 INTERFACE BOARD

The IEEE-488 Interface Board utilizes the Motorola 68488 IEEE IC which is capable of performing all IEEE Talker/Listener protocols. The board was designed to be an interrupt driven I/O device. The board contains Motorola 3448A IEEE bus transceivers, which are capable of driving and terminating the IEEE bus lines per the IEEE-488 specifications.

A rear-panel accessible address switch is on the board for choosing an IEEE Talk/Listener pair address for the Model 619. The IEEE connector is on the rear panel. An Interface Bus Cable (Model 7008), six feet (2-meters) in length, is provided with the Model 6193 module. The five-bit Interface address is back-panel selectable. The address switches are preset, prior to shipment, to primary address of binary 6 (00110).

#### 5.4.1 IEEE Interface Board Theory of Operation

##### NOTE

When reading the theory of operation for the IEEE Interface Board, refer to associated block diagrams and Schematic Diagram 30518 for reference designations.

The Model 6193 IEEE Interface is built around the Motorola 68488 IEEE LSI device U706. The 68488 is a Motorola 6800 family peripheral IC.

The PCB is buffered on data, address, and control lines to present only a 1 bus load. U703 buffers all of the address and control lines. BA0-BA2 make up the RS0-RS2 register selects on the 68488. The 68488 has 16 registers of which 8 are read only and 8 are write only. The use of the R/W (read/write) line allows access to the two 8 register banks. See Table 5-1 for Register Commands.

U707A and U708A decode A11, A12, and IOEN to form  $\overline{\text{BDSEL}}$  (Board Select) (TP1). The  $\overline{\text{BDSEL}}$  decoding will place the PCB at memory space address  $9000_{\text{H}}-97\text{FF}_{\text{H}}$ . This allows 2k of address space for the 68488 of which the first 16 bytes are used. U707B inverts  $\overline{\text{BDSEL}}$  to form  $\text{BDSEL}$ . U708B decodes  $\text{BDSEL}$ , E, and R/W to  $\overline{\text{DRVENB}}$  (Drive Enable) (TP2) which when high allows the inverting tri-state data buffers U711 and U710 to drive the data bus.

U707C inverts the R/W signal to form  $\overline{\text{R/W}}$ . U708C decodes  $\overline{\text{R/W}}$ ,  $\text{BDSEL}$ , and E to form  $\overline{\text{REC ENB}}$  (Receive Enable) (TP3) which when low allows the inverting tri-state data buffers U711 and U710 to receive from the data bus.

The E signal (System  $\Phi$  2) is used in the decoding of U708B and U708C to turn the buffers OFF when they are not driving/sending, thereby lowering their power consumption.

In the 68488 one of the 16 registers R4R is not present on board the chip itself. When the chip decodes this register, it generates  $\overline{\text{ASE}}$  which is used to enable an external register U709 onto the data bus. U709 is a tri-state buffer which is tri-stated when  $\overline{\text{ASE}}$  is high and drives the data lines when  $\overline{\text{ASE}}$  is low. The information on U709's input is provided by address switch S701. S701 is located on the rear panel of the Model 6193 IEEE-488 Interface Board. The necessary pull up resistors for the switch bank are provided by the thick film resistor network R701. The processor reads these switches and then knows which Talker and Listener address to assign to the 68488 chip, and thereby access the instrument.

U702 and U705 are the data bus buffers for the IEEE bus. U704 and U701 are the handshake and control buffers for the IEEE bus. The buffers consist of four independent driver/receiver pairs with bus termination resistors on board. They also have the capability of either tri-state or

**Table 5-1. Register Commands**

RS2	RS1	RS0	R/W	REGISTER TITLE	SYMBOL
0	0	0	1	Interrupt Status	R0R
0	0	0	0	Interrupt Mask	R0W
0	0	1	1	Command Status	R1R
0	0	1	0	NOT USED	---
0	1	0	1	Address Status	R2R
0	1	0	0	Address Mode	R2W
0	1	1	1	Auxiliary Command	R3R
0	1	1	0	Auxiliary Command	R3W
1	0	0	1	Address Switch	R4R
1	0	0	0	Address	R4W
1	0	1	1	Serial Poll	R5R
1	0	1	0	Serial Poll	R5W
1	1	0	1	Command Pass-Through	R6R
1	1	0	0	Parallel Poll	R6W
1	1	1	1	Data In	R7R
1	1	1	0	Data Out	R7W

open collector operation depending on the bus requirement. The Model 6193 is designed to use them in the open collector configuration. U707E, T/R2, and T/R1 form the control for the bus buffers U701, U704, U705, and U702.

U702 and U705 data bus buffers are fully bi-directional as indicated by the arrows on the schematic (30518). U701 Pins 3, 5, and 13 (which are NRFD, NDAC, and DAV respectively) are also fully bi-directional. U704 Pin 11 (EOI) is fully bi-directional. U707 Pin 11 (ATN) and U704 Pins 3 and 13 (REN and IFC respectively) are receive only and U704 Pin 5 (SRQ) is send only. A typical section is shown in Figure 5-4.

VR701 supplies the +5 volt  $\pm 5\%$  regulated power needed by the PCB.

### 5.5 CPU BOARD

The CPU board has a circuit which resets the processor upon power up to ensure proper system operation. This circuit can also be controlled via the watchdog line from one of the interval timers in case of program malfunction. This function will be discussed in more detail later in this section. The CPU has provisions for 8K words of ROM (or EPROM) program memory on board with decoding for an additional 8K ROM external. It also has provisions for up to 2K RAM

scratch-pad memory on board. With the 6840 LSI chip, the CPU can have three hardware interval timers. It can support both interrupt and DMA driven I/O systems. A 4MHz crystal oscillator is used to provide all timing for the 6808 CPU chip and digital system components. A partially decoded I/O enable line (IOEN) is provided for use by system I/O components to ease their memory space decoding. The board is capable of supporting signature analysis troubleshooting techniques.

### 5.5.1 CPU Theory of Operation

#### NOTE

When reading through the theory of operation for the CPU board, refer to Schematic Diagram 30519 for reference designations.

The Model 619 Electrometer/Multimeter control processor unit (CPU) is constructed around the Motorola 6808 microprocessor (U905). This particular processor is a Motorola 6800 series processor with an internal clock.

The Motorola 6808 LSI microprocessor requires a 20msec reset pulse when power is turned on to get its dynamic buffers and the clock running properly. This reset delay is provided by timer U917. The output of U917 is inverted by U916D and applied to the reset pin of the microprocessor

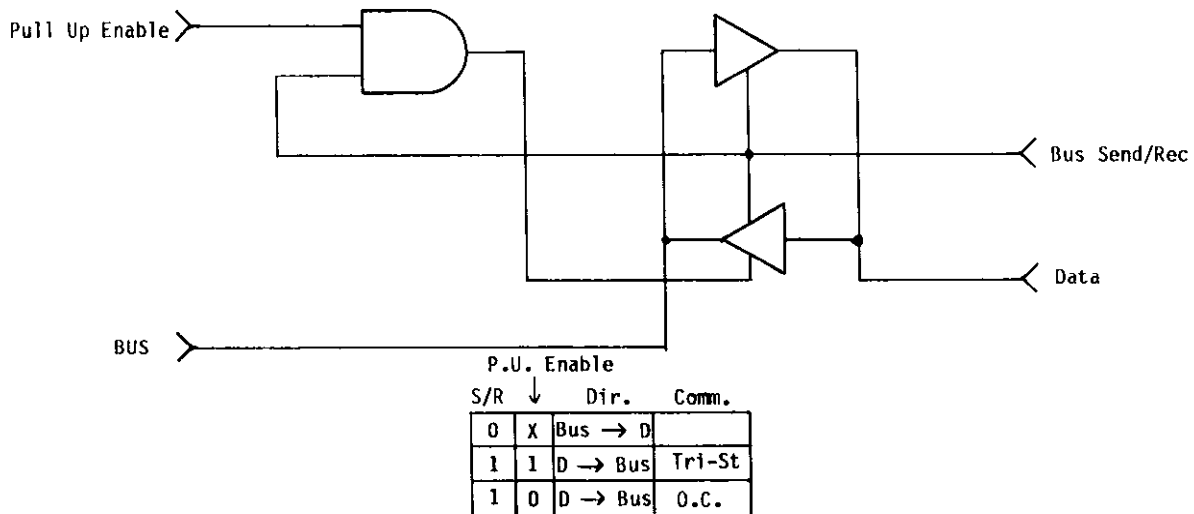

Figure 5-4. Data Bus Buffer

(Pin 40). It also goes to all other devices in the system which require power up resets via bus Pin 28 (i.e., PIA's, VIA's, etc.)

U913 is a Motorola 6840 timer peripheral. It is part of the Motorola 6800 series family of parts. The 6840 (U913) contains three fully programmable hardware timers with interrupt and output capability. U913c is controlled by the 6840 (U913) software controllable timer 1, which monitors the running software. U913 timer 3 is used to establish real time interrupts to the running software. U913 timer 2 outputs a 120Hz signal on Pin 3 (TP12) to allow oscilloscope monitoring for determining whether the IC is functional. U913 is an I/O device to the system, U902B decodes BA9, BA10, BA11, and BA12 to form one chip select for U913. The other chip select for U913 is provided by BIOEN which will be discussed later in this section. The memory space is  $9E00_H-9FFF_H$ , of which eight locations are used by the chip. Placing U913 in the I/O configuration gives it added flexibility in that it can be used by DMA (Direct Memory Access) devices or other I/O components if needed. See Table 5-2 for Register Commands.

The 6808 microprocessor data bus  $D0-D7$  is buffered and inverted by U921 and U918 to form  $\overline{BD0-BD7}$  and is provided to the system. The unbuffered data bus is routed to all the memory devices on the PC board. The control for data transfer into the CPU is derived by U903B (TP7). It decodes  $\phi 2$ , A15, A13, and R/W to form the RECENB (Receive Enable) signal. The  $\overline{RECENB}$  signal allows the buffer to receive from the data bus. The control for data transfer into the CPU is derived by U904C (TP6). It decodes R/W, BA,  $\overline{B\phi 2}$  to form the DRVENB (Drive Enable) signal. The DRVENB signal allows the buffer to drive the data bus.

Decoded  $\phi 2$  is used for all of the buffers in order to make them tri-state for reduction in power consumption.

The 6808 address bus  $A0-A15$  is buffered by U908 and U901 to form  $BA0-BA15$  which is provided to the system. To aid I/O device decoding in the system BA13, BA14, BA15, and BVUA are decoded by U909C, B, A, and U902A to form the IOEN (I/O Enable) signal. This signal is buffered by U911 to form BIOEN. In addition to IOEN, U911 does all

Table 5-2. Register Commands

RS2	RS1	RS0	R/W=0	R/W=1
0	0	0	CR2=0 Write #3 CR1=1 Write #3	NOP NOP
0	0	1	Write Control Register #1	Read Status Register
0	1	0	Write MSB Register	Read Timer #1 Counter
0	1	1	Write Timer #1 Latch	Read LSB Register
1	0	0	Write MSB Register	Read Timer #2 Counter
1	0	1	Write Timer #2 Latch	Read LSB Register
1	1	0	Write MSB Register	Read Timer #3 Counter
1	1	1	Write Timer #3 Latch	Read LSB Register

the control line buffering; it buffers I, R/W, VMA (to form BVUA) and BBA/DMAGNT (Direct Memory Access Grant) for use by the Model 619 System.

All on board ROM memory decoding is done by U914A, U903A, U904A, U912, and U910B. U903A and U904A form the ROME (ROM Enable) signal. This enables U914A, the 2 or 4 decoder to select the appropriate device based on A11 (Pin 2) and A12 (Pin 3) of U914. The 6808 requires vectors from memory to branch to various sections of software. These vectors must appear in locations FFF8<sub>H</sub>-FFFF<sub>H</sub> in the memory space.

The Vector JAM signal allows the top block of ROM to be double address for this purpose. The top block responds to FFF8<sub>H</sub>-FFFF<sub>H</sub> as well as its normal address. U912D and U912C perform the necessary "OR"ing function. Therefore, DSEL4 (TP4) decodes memory spaces B800<sub>H</sub>-BFFF<sub>H</sub> and E000<sub>H</sub>-FFFF<sub>H</sub>. Signal DSEL1 (TP3) decodes A800<sub>H</sub>-F<sub>H</sub> memory space, ROM U924. Signal DSEL2 (TP2) decodes A800<sub>H</sub>-AFFF<sub>H</sub> memory space, ROM U915. Signal DSEL3 (TP1) decodes B000<sub>H</sub>-B7FF<sub>H</sub> memory space, ROM U907. The above process is used for 2716 memory devices. Refer to Table 5-3 for selection of PROMS. DSEL3 selects A000<sub>H</sub>-AFFF<sub>H</sub> memory space, ROM U907, and DSEL4 selects B000<sub>H</sub>-BFFF<sub>H</sub> memory space, ROM U906, as there is only 8K maximum of ROM allowed. Memory space C000<sub>H</sub>-DFFF<sub>H</sub> is reserved for external ROM. See Figure 5-5 for memory space map.

**NOTE**

The subscript H, as in E000<sub>H</sub>, denotes a hexadecimal location in memory or hex notation of a number.

All of the on board RAM decoding is done by U904B and U914B. U904B decodes A14, A15, and  $\Phi$ 2 to form RAME (RAM Enable) which enables U914B the 2 of 4 decoder. When A13 is low, depending on the state of A10 (Pin 14), either SRAM1 (Select lower 1K) memory space 0000<sub>H</sub>-03FF<sub>H</sub> or SRAM2 (Selected upper 1K) memory space 0400<sub>H</sub>-07FF<sub>H</sub> is generated to select the appropriate RAM bank. The RAM chips are 1K by 4K (21147) memory devices; thus two chips in each bank are necessary for the required 8 bits of data. U919 and U920 are the low order 4 bits and U922 and U923 are the high order 4 bits. The other signal needed by the RAM's is the WE (Write Enable) signal. This signal is generated by U910C and U909F which decode R/W,  $\Phi$ 2, and VMA.

The 5VDC regulated to  $\pm$ 5% is provided by VR901 and associated capacitors. Crystal Y901 and capacitors C910 and C911 form the 4MHz oscillator clock needed by the 6808 IC. The 6808 divides this frequency by 4 and provides a 1MHz output (Pin 37) E clock for system synchronization.

**5.6 ISOLATOR BOARD**

The Isolator board interfaces digital bus A to analog bus B. Four optical isolators are utilized for signal coupling without impedance coupling. Data, control, and address information is transmitted (with odd parity) to the analog side of the isolator, using three of the optical isolators. At the same time data from the A/D is transmitted to the digital side of the Isolator board across the fourth optical isolator.

The Isolator board also provides address decoding and power for the display board as well as buffering for all lines going to the display board from the digital bus.

**Table 5-3. Jumpers for PROM Selection**

Configuration	W901	W902	W903	W904	W905	W906	W907	W908	W909
2716 PROMS (2k)	0	X	X	0	*	X	X	X	
2732 PROMS (4k)	*	X	X	*	0	X	X	X	0
X = Don't Care      * = In      0 = Out									

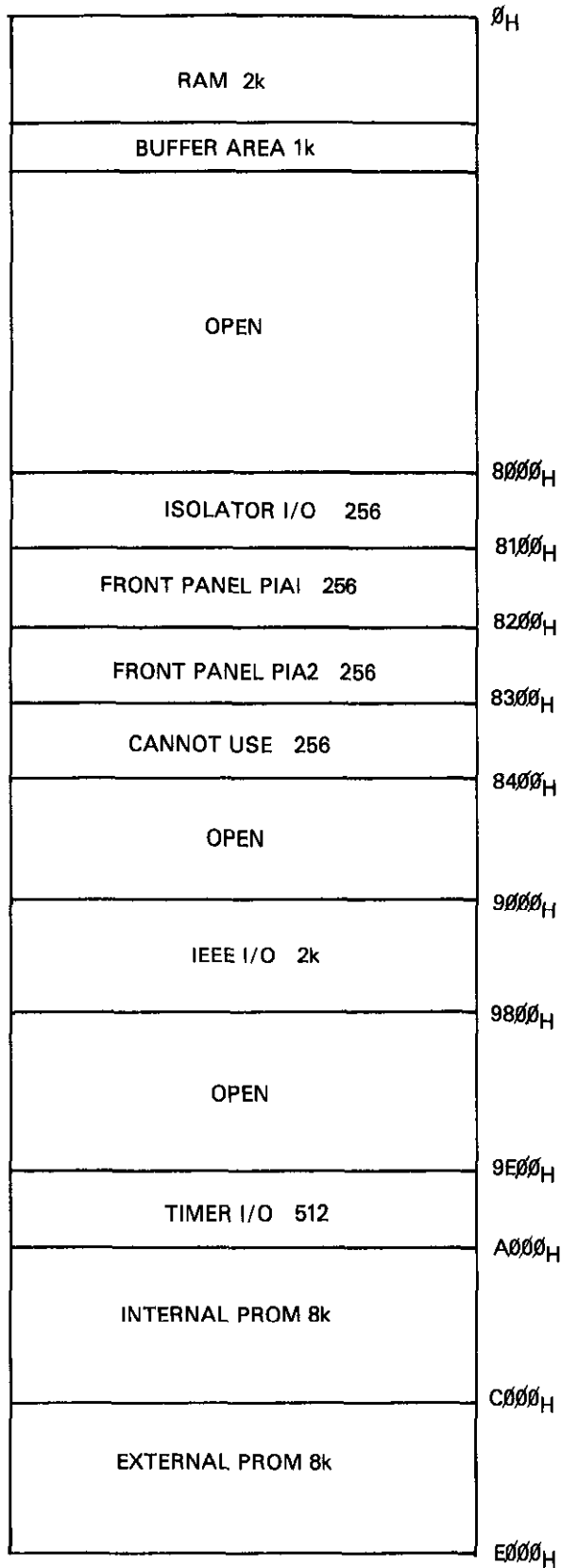

Figure 5-5. Memory Map

### 5.6.1 Isolator Board Theory of Operation.

#### NOTE

When reading through the theory of operation for the Isolator Board, refer to Schematic Diagram 30520D.

The Model 619 Isolator board is designed around the Synertek 6522 Versatile Interface Adapter (U807).

The board is buffered on data, control, and address lines to present one bus load to the Model 619 bus. U805 and U806 buffer the data lines. U803 buffers the control and address lines. U801E, F, and U804A decode BA12, BA11, and BIOEN respectively to form BDSEL (Board Select) signal. There is no buffering on lines BA12, BA11, and BIOEN as well as BA8, BA9, and BA10 since they only represent one load to the bus. U801A inverts BDSEL to form BDSEL. There is also one chip select for U807. BDSEL is also inverted by U801B to form one chip select for the display board PIA's.

U802A decodes BA8, BA9, and BA10 to form other chip selects for the interface. U802A Pin 4 selects U807. This decoding arrangement places U807 in memory space 8000-80FF allowing 256 memory locations, however, only 16 are used. U802A Pin 5 forms S1 which selects U204 on the display board. This arrangement provides 256 memory locations of which only four are used.

U802A Pin 6 forms S2, which selects U207 on the display board. This provides 256 memory locations of which only four are used. U802A Pin 7 is not used. All of the additional signal control lines needed by the display board, E, A6, A7, and R/W, are buffered by U803. The Data lines D0-D7 are buffered by U805 and U806. Reset and +5VDC and ground (B com) are not buffered. All of these lines go to the display board through connector 801.

U804C and U801C decode R/W, E, and BDSEL to form DRVENB (Drive Enable) (TP1) in order to gate the data buffers and to send data to the data bus.

U801D and U804B decode R/W, E, and BDSEL to form RECENB (Receive Enable) (TP2) in order to gate the data buffers for receiving from the data bus.

The heart of the Isolator board is the Synertek 6522 Versatile Interface Adapter (VIA) a fully programmable I/O device. The VIA internally consists of 2 software programmable timers, 2 programmable bi-directional 8-bit parallel I/O ports (similar to PIA's) and a serial communication port. The device contains control registers which are programmable in determining which of the many modes of operation are to be utilized. Lines CB1 and CB2 form the serial communications port and PA0-PA7 (Port A) and PB0-PB7 (Port B) form the bi-directional parallel I/O ports. Internal register bits are shown below in Table 5-4.

Table 5-4. Register Commands

RS3	RS2	RS1	RS0	Register	Comments
0	0	0	0	ØRB, IRB	Effect Handshake
0	0	0	1	ØRA, IRA	Effect Handshake
0	0	1	0	DDRB	Data Direction B
0	0	1	1	DDRA	Data Direction A
0	1	0	0	T1	Timer 1
0	1	0	1	T1	Timer 1
0	1	1	0	T1	Timer 1
0	1	1	1	T1	Timer 1
1	0	0	0	T2	Timer 2
1	0	0	1	T2	Timer 2
1	0	1	0	SR	Serial Port Data
1	0	1	1	ACR	Control Register
1	1	0	0	PCR	Peripheral Control
1	1	0	1	IFR	IRQ Mask
1	1	1	0	IEB	IRQ Enable
1	1	1	1	ØRA	No-Effect Handshake

For the serial I/O, the clock is programmed for a 500kHz shift rate. The parallel I/O Port A lines PA0-PA7 are programmed as inputs and Port B lines PB3-PB7 are also programmed as inputs. Port B lines and PB0 are programmed as outputs.

The actual operation is as follows: A byte of data is written via the software into the 6522 (VIA) serial out register. The LSI device forms the clock and data for the serial bit streams on CB1 and CB2. The clock bit stream goes through U809A and opto isolator AT3 and U810A to be the shift clock for U812, U815 serial to parallel converters, and U816 parallel to serial converter on the isolated side. U809A Pin 14 is a clock enable which is utilized to disable the clock if the need arises. U809A also provides the drive needed by the opto isolator AT3. The data bit stream goes through opto isolator AT3 and U810A to be the data for shift register U812 and U815. U809B provides the drive for the opto isolator AT2. U811 and U814 are generator parity/checker devices.

When the shifting is completed and U811 Pin 5 goes low, this indicates odd parity. During the shifting operation, this line goes low many times depending on the state of the shift registers. Therefore, U810B Pin 9 is an enable line, so that when the data has been sent, the software causes an enable low after shift. On the analog/digital bus this is used as an address latch enable signal to latch in the address of the analog device to which data is being sent. The data to be written is placed on the outputs of U815 and the address is placed on the outputs of U812. The software then sends PB2, which disables the address latch enable, making the enable line go high. At the same time U810D Pin 4 (latch line) goes low, this causes the ACK line path to be selected and ACK (Acknowledge) will be sent back from the analog side. If the receiving analog device has latched in its address, it responds via the ACK line. This is inverted by U813A and goes to opto isolator AT4 and then to U807, CA1, and PB7. CA1 interrupts the system when the ACK line becomes true. Polling can be done to sense a change on PB7. U813C provides the drive needed by the opto isolator AT4. There are 2 types of error checking in transit. A parity check followed by an ACK handshake completion. Upon error, retransmission of data can be requested via the software.

To receive data from the analog side, U807 PB2 is set to disable the ACK path and enable the data path via U813D Pin 12. The data shifts out at clock CB1 rate from U816 going through U813C, D, and opto isolator AT4 into serial parallel converter U808. It is then presented to U807 Port A. The software can then read the 8-bit data. On receive U816 recirculates the data presented to it by the analog side. Thus, multiple reads and compares may be done via software to enable error checking for receive data. Upon error, retransmission of data can be requested via the software.

For test purposes Jumper J1 is provided to allow the Isolator to recirculate data or talk to itself (provided U815 Pin 13 is not being interrupted by the analog bus).

Jumper J2 allows for odd parity checking, or no parity checking depending on the system needs.

The regulated 5V  $\pm$ 5% is provided to the isolator digital side by VR801 and associated capacitors.

## 5.7 DISPLAY/KEYBOARD

The display/keyboard has three main areas, the keyboard, annunciators, and numeric displays. The keyboard area consists of a four by six matrix for a total of 24 switch locations. Sixteen of these switches are used in the Model 619 to select range, function and channel. The annunciator area consists of 23 LED's. The Model 619 uses 21 annunciators to display the status of the instrument. The display area consists of a signed 5½-digit mantissa and a signed 2-digit exponent.

All the display board hardware decoding is done on the ISOLATOR PCB. The decoding places the PCB at memory address 8100<sub>H</sub>-82FF<sub>H</sub>. U204 is located at 8100<sub>H</sub>-81FF<sub>H</sub> and U207 is located at 8200<sub>H</sub>-82FF<sub>H</sub>. The power for the display board is also derived from the Isolator board. All signal and power lines are delivered to the display PCB via the connector cable.

### 5.7.1 Display/Keyboard Theory of Operation

#### NOTE

When reading through the theory of operation for the display/keyboard, it will be helpful to refer to Schematic Diagram 30515.

The heart of the display board consists of U204 and U207 Motorola 6800 family peripheral interface adapter chips (PIA's) which are fully software programmable.

The PIA's internally consist of two programmable control registers which determine which of many modes of operation are to be used. The PIA's also contain two programmable data direction registers, which are also data I/O registers if bit 2 in the corresponding control register is set to 1. Both control registers are initialized to 3C<sub>H</sub>. This configures the PIA's for non-interrupt operation standard mode.

Data direction is configured for U204 by Port A outputs and Port B outputs, and for U207 by Port A inputs and Port B outputs.

U204 I/O Port B is the common cathode control strobe used to turn the display on. Each of the eight lines turns on one bank of LED's plus one display digit. U207 I/O Port B is the segment select control to select appropriate segments of the display digits U204 I/O Port A lines. PA0, PA1, and PA2 are the LED select controls to select the appropriate



LED in the LED bank. U204 I/O Port A line PA3 is used to key the beeper on and off; U204 Port A lines PA4-PA7 form the column lines to the switch matrix and U207 Port A lines form the row lines to the switch matrix. U204 Port A lines PA4-PA7 are used to enable the appropriate switch column for the software switch scan. U207 Port A is used to read the scanned switch bank to determine which switch has been depressed. Switch debounce, N key rollover, and switch validation are all done in software.

U201, U203, and U205 are buffers to drive the displays, LED's, and switches.

### 5.8 A/D BOARD

The A/D board consists of the basic hybrid charge balance dual slope A/D. There are no references or multiplexed inputs. The control of this board is from the CPU board through the digital Isolator board.

The input voltage is converted into a current in the GAMP (Transconductance Amplifier). When the output of the Integrator ramps up to the threshold of the "D" flip-flop, the 2mA current source is turned on until the output of the Integrator ramps down below the threshold of the "D" flip-flop. The number of pulses produced is accumulated in the Event Counter.

Upon completion of Signal Integrate, and based on the length of time determined by the number loaded into the Integration Time Counter, the number in the Event Counter is multiplexed into the processor. The Event Counter is cleared and the Single Slope current source is switched on. The time required to ramp to zero is measured by counting the clock in the Event Counter. This number is also multiplexed into the processor. From these two numbers the total number of counts can be calculated.

#### 5.8.1 A/D Theory of Operation

##### NOTE

When reading through the theory of operation for the A/D board, refer to Schematic Diagram 30521.

The Transconductance Amplifier (GAMP) performs two functions:

1. Converts the input signal voltage to a current for the integrator.
2. It provides an offset to make the A/D bipolar. That is a plus and minus voltage for input to the A/D.

The op amp reference is biased at approximately -2.5 volts or minus full scale by VR501 as a negative reference, and by resistors R501 (25k) and KR501 (39k). Resistor R501 (3.9k) forms a current source due to the constant voltage across it. It is equal to the voltage across R501 (39k) due to the feedback action of the op amp.

Ib is set to approximately the value of  $V_{in\ max}/R_{in}$ .

Then  $V_{in} = V_{max}, I = 0$   
 $V_{in} = 0, I = I_b$   
 $V_{in} = V_{max}, I = 2I_b$

The charge balancing consists of an integrator, a positive current source with a current switch, and the negative signal current.

When U513 Pin 1 (Signal Integrate) goes low, Isig (Signal Current) flows out of the summing junction and ramps up to the threshold of the "D" flip-flop, therefore, the current Icb (Charge Balancing Current) is turned on for one clock period. Icb is slightly greater than Isig full scale.

The value of C502 which is the integrator capacitor prevents the output of the integrator from ramping below ground or above +5 volts.

U513A enables charge balance pulses only during Signal Integrate. Q503 prevents current limiting in the output of U507 op amp and clamps the output of the integrator to  $\pm 5$  volts to protect the "D" flip-flop. U507 is a FET input op amp that prevent any extra currents from flowing out of the summing junction during the instantaneous overloads as the charge balance pulses or signal current are switched OFF and ON.

R503 is a linearity resistor. The nonlinearity in the A/D is a square law curve. The amount of current removed from the summing junction by this resistor is proportional to the voltage across the diode junction to the summing junction in U507. This induces a compensating logarithmic nonlinearity. The basic nonlinearity is only 10 to 50ppm. The compensation corrects this error to 1 to 10ppm.

The residual charge on the capacitor is ramped down to zero volts by the Start Single Slope control signal. The single slope current is 1/128 of the charge balance current. This ratio is between R501 (320k) and R501 (2.44k) taking into account the base emitter coltage drops of Q505, Q506, and Q507d. However, the charge balance is on only 50% of the time, so the effective ratio is 1/256 (Refer to Event Counter Operation). During operation, the last digit displayed is approximately the single slope contribution, so this ratio only has to be accurate to 1% to 10%.

The IMC1 line has 10 volts on it and is a byproduct of the reference circuit on the Filter/Mux board.

The Clock is composed of an oscillator and a divider circuit. The oscillator is a classic Pierce oscillator circuit developing 4.915MHz. U516 (74193) divides the oscillator frequency to 307.2kHz and 614.4kHz. The 307.2kHz after being buffered by U508A is divided down even further to 1200Hz by U505 (LS393). The 614.4kHz is gated into the charge balance circuit through U513C and B.

The A/D essentially runs on its own until it has data for the processor at certain essential times during the conversion.

The Event Counter is a 16 bit binary counter that is used in two modes. The first mode is to count the number of charge balance pulses during Signal Integrate. The second mode is to count the 5MHz clock during the ramp down of the Single Slope. Using the 5MHz clock in this manner, makes one Single Slope count equal to 1/1024 of charge balance counts. The resolution is thereby increased. The output of this counter is multiplexed to the Data In Bus, and then to the processor, 8 bits at a time.

The Integration Time Counter consists of an 8 bit prescaler counter U505 and an 8 bit programmable down counter U509 and U510. U505 receives its input from the lowest frequency tap of the oscillator divider. U505 drives U510 and therefore U509 with a frequency of 1200Hz. U509 and U510 are loaded from the processor. Thus, the integration time can be programmed in increments of 833 microseconds. This is convenient for integration periods of 16.66msec or 20msec.

The Control Bit Latch register, U517, holds the control bits, to set up the various control and data paths on this board.

1. Bit 0, LS byte A turns on the tri-state buffer, U512, onto the Data In Bus.
2. Bit 1, MS byte A0 turns on the tri-state buffer, U519, onto the Data In Bus.
3. Bit 2, Single Slope A1 starts slope and remains at logic level 1 during the complete ramp down. The counting and the ramping will stop automatically when the ramp has crossed zero.
4. Bit 3, Parity. this is not used in hardware. It is used for the parity bit in software.
5. Bit 4, Force Integration is normally a logic 1 for the present software, but is could be used to produce long integrations under direct processor control.
6. Bit 5, Event Counter ACK Enable normally a logic 1 in present software. It is used to sense MSB of Event Counter on the ACK line when an overflow occurs in a long integration.
7. Bit 6, Integrate ACK Enable is normally a logic 1 in present software. ACK is asserted during the time the integration time counter is counting.
8. Bit 7, Clear A1 resets all counters to zero and thus stops all functions in progress.

A 3 input Nand gate package (U504) is used to decode so that only 3 of 8 bits are high at any time. There are two addresses on the board.

1.  $B0_H$  latches the data on the control Bus into the Integration Time Counter. The address must be present for 4 microseconds and no longer than the integration time, otherwise it will retrigger the integration.
2.  $A8_H$  latches the data on the control bus into the Control Bit Latch on the trailing edge of the address decoding.

#### NOTE

The ACK line is low under the conditions described in the preceding steps 1 through 8.

### 5.9. FILTER/MULTIPLEXER BOARD

#### NOTE

When reading through the theory of operation for the Filter/Mux board, refer to Schematic Diagram 30524.

The Filter/Mux board consists of the signal conditioning circuitry and references for the A/D board. Channel A and B Electrometers are selected by the appropriate relays. These relays (K401 and K402) connect signal and ground on the Electrometer module to the A/D's signal and ground inputs.

The Signal FET Driver amplifier (U405) is used to minimize charge injection from the gate source capacitance of the FET, into the filter when it is in use.

The Input Buffer (U404) is bootstrapped for linearity. It can be switched from a times one gain to a times ten gain. Two references are available for calibration; a 2 volt reference and a 0.2 volt reference.

The Electrometer Multiplexing relays switch signal and ground from the two Electrometer modules to the input of the A/D. The switching is done by K401 and K402. The relays also provide isolation between the two channels.

The Ground Relay K405 protects K401 and K402 from arcing or flashover when switched to the A/D. A large transient is possible when this happens due to the stray capacitance between the A/D ground and the Electrometer ground R431 (10k) limiting the current during the transient. K405 is then closed to eliminate rejection problems caused by having the resistor in the ground lead.

The RC filter, which is a single pole filter, can be switched into the input of the A/D Converter via relays K403 and K404. The filter consists of C408 and C409, R433, R436, and R437.

The neon bulbs DS401 and DS402 fire at approximately 85 volts in order to protect the capacitors in the filter from over voltage. The leakage resistance at this point, due to the neon bulbs, will be an order of magnitude less than the least significant digit, i.e., approximately 1ppm. This means the off resistance of the neon bulbs is  $> = 130Gohms$ .

The short time constant RC (C410 and C411, R436, R437, R433, and R434) is included to suppress high frequency noise from the output of the Electrometer modules. When K403 and K404 are actuated, R435 and R432 limit the resulting discharge current.

Protection for the input to the A/D Buffer amplifier is provided by FET's Q407 and Q412. They clamp the input to  $\pm 5$  volts.

The op amp U405 provides a zero volt difference bias voltage for the signal FET Q409 and compensating FET Q406. Q406 provides cancellation of the charge injection due to gate-drain capacitances of these FET's into the filter capacitors C408 and C409.

FET's Q410, Q408, and Q411 provide inputs for Zero, 2 volts, and 0.2 volts respectively.

The A/D Buffer Amplifier is an X1 or X10 gain, high input impedance, low output impedance stage to couple the various inputs to the 5k input of the A/D board. The different gains are obtained by switching in the different feedback resistors. The resistors are R418 and R419. They are switched in and out by FET's Q404 and Q405. The op amp has a bootstrapped power supply of  $\pm 6$  volts. The bootstrap supply consists of U403, Q401 and C403, R404, and R407. The bootstrap ground potential is the potential at the summing junction of U404. This ground is used to reference the drive resistors of the other input FET's Q408, Q410, and Q411. Decoupling or compensation to prevent instability in the bootstrap is provided by RC's, C403/R404 and C402/R405.

The control or logic section consists of two latches. One latch to switch relays and one latch to control the FET switches for the A/D buffer amplifier. U408, which is the FET control latch, clocks in the data that is on the control bus on

the trailing edge of address  $E_0^H$ . The output of U408 drives U406 and U407 which are open collector comparators. These comparators are used to level shift the 0 to 3 volt TTL signal to -15 to +5 volt signal to drive the FET switches.

Assignments are signals to drive the FET switches. The bit assignments are as follows:

1. Bit 0, A1 put the buffer amplifier in X10 gain.  $A_0$  puts it in the X1 gain.
2. Bit 1, A1 turns on the signal FET (Q409).
3. Bit 2, A1 turns on the zero FET (Q410).
4. Bit 3, A1 turns on the 2 volts FET (U408).
5. Bit 4, A1 turns on the 0.2 volts FET (Q411).
6. Bit 5, not used.
7. Bit 6, A1 turns on the charge compensating FET (Q406). The software drives this bit with the compliment of Bit 1.
8. Bit 7 Parity. Not used in hardware.

U409, which is the relay latch, clocks in data that is on the control bus on the trailing edge of address  $D_0$ .

The bit assignments are as follows:

1. Bit 0,  $A_0$  turns on relay K401, Channel A.
2. Bit 1,  $A_0$  turns on relay K403, Channel A's filter capacitor.
3. Bit 2,  $A_0$  turns on relay K402, Channel B.
4. Bit 3,  $A_0$  turns on relay K404, Channel B's filter capacitor.
5. Bit 4,  $A_0$  turns on relay K405 ground relay.
6. Bit 5, not used.
7. Bit 6, not used.
8. Bit 7, Parity. Not used.

**Table 5-5. Analog Bus Connector Pin Assignments Valid for Channel A**

SIGNAL	PIN	PIN	SIGNAL
A COM*	1	2	A COM*
33VAC	3	4	33VAC
A COM*	5	6	A COM*
BLANK	7	8	BLANK
BLANK	9	10	BLANK
CH A HI	11	12	CH A HI
CH A LO	13	14	CH A LO
A COM*	15	16	A COM*
A COM	17	18	A COM
A COM	19	20	A COM
A COM	21	22	A COM
+ 15VDC	23	24	- 15VDC
+ 5VDC	25	26	+ 5VDC
+ 5VDC	27	28	+ 5VDC
A COM*	29	30	A1
A0	31	32	A2
A3	33	34	A4
A5	35	36	A6
LATCH ENABLE	37	38	A COM*
D00	39	40	C01
D02	41	42	D03
D04	43	44	D05
D06	45	46	D07
A COM*	47	48	/ACK
IM A0	49	50	IM A1
IM A2	51	52	IM A3
IM A x (CH A LO)	53	54	IM A5
IM A6	55	56	IM A7
IM A8	57	58	IM A9
IM A10	59	60	IM A11
IM A12	61	62	IM A13

\*Shielding ground not to be used as a current supply line.

**Table 5-6. Analog Bus Connector Pin Assignments Valid for Channel B**

SIGNAL	PIN	PIN	SIGNAL
A COM*	1	2	A COM*
33VAC	3	4	33VAC
A COM*	5	6	A COM*
CH A HI	7	8	CH A HI
CH A LO	9	10	CH A LO
CH B HI	11	12	CH B HI
CH B LO	13	14	CH B LO
A COM*	15	16	A COM*
A COM	17	18	A COM
A COM	19	20	A COM
A COM	21	22	A COM
+ 15VDC	23	24	- 15VDC
+ 5VDC	25	26	+ 5VDC
+ 5VDC	27	28	+ 5VDC
A COM*	29	30	A0
A1	31	32	A2
A3	33	34	A4
A5	35	36	A6
LATCH ENABLE	37	38	A COM*
D00	39	40	D01
D02	41	42	D03
D04	43	44	D05
D06	45	46	D07
A COM*	47	48	/ACK
IM B0	49	50	IM B1
IM B2	51	52	IM B3
IM B4 (CH A LO)	53	54	IM B5
IM B6	55	56	IM B7
IM B8	57	58	IM B9
IM B10	59	60	IM B11
IM B12	61	62	IM B13

\*Shielding ground not to be used as a current supply line.

**Table 5-7. Electrometer Control**

ADDRESSES	BYTE	A/D RANGE
CHANNEL A, FUNCTION BYTE	000 0101 (05)	
RANGE BYTE	000 1001 (09)	
CHANNEL B, FUNCTION	000 0110 (06)	
RANGE BYTE	000 1010 (0A)	
VOLTS	1*11 0111 (FF, B7)	
VOLTS, ZERO CHECK	1*11 0011 (FB, B3)	
OHMS		
1kohm to 10kohm	0*01 0110 (5E, 16)	
100kohm to 100Mohm	1*01 0110 (DE, 96)	
1Gohm to 1000Gohm	1*11 0110 (EE, B6)	
OHMS, ZERO CHECK		
1kohm to 10kohm	0*01 0010 (5A, 12)	
100koh, to 100Mohm	1*01 0010 (DA, 92)	
1Gohm to 1000Gohm	1*11 0010 (EA, B2)	
AMPS		
External Feedback	1*11 0101 (FD, B5)	
1nA to 1 $\mu$ A	1*11 0101 (FD, B5)	
10 $\mu$ A to 100 $\mu$ A	0*11 0101 (7D, 35)	
1mA to 10mA,		
External Feedback	1*11 0101 (FD, B5)	
1A	1*10 0101 (ED, A5)	
AMPS, ZERO CHECK		
1nA to 1 $\mu$ A	1*10 0101 (ED, A5)	
10 $\mu$ A to 100 $\mu$ A	0*10 0101 (6D, 25)	
1mA to 10mA,		
External Feedback	1*10 0101 (ED, A5)	

RANGE BYTE	BYTE	A/D RANGE
VOLTS		
100mV	1111 0111 (F7)	100mV
1V	1111 0111 (F7)	1V
10V	1101 1101 (DD)	1V
100V	1111 1101 (FD)	1V
OHMS		
1kohm	1111 0011 (F3)	100mV
10kohm	1111 0011 (F3)	1V
100kohm	1111 0011 (F3)	100mV
1Mohm	1111 0011 (F3)	1V
10Mohm	1110 0111 (E7)	100mV
100Mohm	1110 0111 (E7)	1V
OHMS		
1Gohm	1100 1101 (CD)	1V
10Gohm	1011 0111 (B7)	1V
100Gohm	1001 1101 (9D)	1V
1000Fohm	1011 1101 (BD)	1V

**Table 5-7. Electrometer Control (Cont.)**

AMPS		
1nA	1110 0111 (E7)	100mV
10nA	1110 0111 (E7)	1V
100nA	1111 0011 (F3)	100mV
1 $\mu$ A	1111 0011 (F3)	1V
10 $\mu$ A	1111 0011 (F3)	100mV
100A	1111 0011 (F3)	1V
1mA	0111 0111 (77)	100mV
10mA	0111 0111 (77)	1V
1A	1111 1110 (FE)	100mA
External Feedback	1111 0111 (F7)	1V

\*Range Disabled Bit (D06)

1 Range Byte control disabled

0 Range Byte control enabled

Byte data is binary.

Data in parenthesis is in hexadecimal notation.

**Table 5-8. Control Data Bit Designations**

DATA BIT	FUNCTION BYTE	RANGE BYTE
<del>D00</del>	K658 Ohms Reference	K603 1Amp
<del>D01</del>	K601 Volts/Ohms	k662 X0.1/X0.01 Output
<del>D02</del>	K656 Volts/Ohms, Zero Check	K652 1Mohm/10kohm Feedback
<del>D03</del>	Not Used	K661 X1 Output
<del>D04</del>	K655 Amps, Zero Check	K653 100Mohm Feedback
<del>D05</del>	K659 ohms Input Voltage Limit	K660 X0.1 Output
<del>D06</del>	Range Disable	K654 10Gohm Feedback
<del>D07</del>	K657 10kohm Feedback	K651 100ohm Feedback

\*Relay Designation Refer to Schematics 30522D and 30523.

## SECTION 6 MAINTENANCE

### 6.1 INTRODUCTION

This section contains information necessary to maintain the Model 619. Adjustment calibration, troubleshooting and fuse replacement procedures are provided.

### 6.2 PRE-POWER UP PROGRAMMING

The top cover of the Model 619 must be removed to check or change the LINE VOLTAGE, LINE FREQUENCY and BEEPER switches. To remove the top cover, remove the two retaining screws located at the rear of the instrument and lift the cover off.

#### WARNING

**All service information is intended for qualified electronic maintenance personnel only.**

#### WARNING

**To prevent a shock hazard, remove the line cord and all test leads from the instrument before removing the top cover.**

#### 6.2.1 Line Voltage and Frequency Selection

Position switches and install appropriate fuse as follows (refer to Figure 5-2):

1. Remove the power supply shield by carefully lifting it off of the four retaining clips.

2. Set up switches S301 and S302 per instructions given in Table 6-1. Instructions are also printed on the power supply shield.
3. Refer to Table 6-1 and select and install the properly rated line fuse.

#### CAUTION

**Installing a higher rated fuse than the one specified could result in damage to the instrument.**

4. Reinstall the power supply shield.

Select the appropriate line frequency by setting switch 4 of S801 (Figure 6-1) to the closed position (0) for 60Hz operation or to the open position (1) for 50Hz operation. If the Model 619 is on while changing the switch position, the new frequency setting will not be accepted until the instrument is turned off and then powered back on.

### 6.3 BEEPER SELECTION

The beeper is programmed to be operational at the factory; however, it can be disabled if so desired.

1. Remove the top cover.

#### WARNING

**To prevent a shock hazard, remove the line cord and all test leads from the instrument before removing the top cover.**

**Table 6-1. Line Voltage Selection**

Line Voltage	S301 HI-LO Switch	S302 110-220V Switch	Type	Keithley P/N
90V-110V	LO	110V	3AG, SLO BLO 250V, 1A	FU-10
105V-125V	HI	110V	3AG, SLO BLO 250V, 1A	FU-10
180V-220V	LO	220V	3AG, SLO BLO 250V, 1/2A	FU-4
210V-250V	HI	220V	3AG, SLO BLO 250V, 1/2A	FU-4



2. Set switch 1 of S801 on the Isolator Board to the open position (1) (refer to Figure 6-1).
3. Reinstall the top cover.

### 6.4 READING RATE SELECTION

When the Model 619 is in the Front Panel Mode and the 5 1/2 digit resolution mode, two different reading rates can be chosen via S5 (2.41 rdg/sec) or S8 (0.30 rdg/sec). See Table 2-6. To select the S5 reading rate:

1. Remove the top cover.

#### WARNING

To prevent a shock hazard, remove the line cord and all test leads from the instrument before removing the top cover.

2. Set switch 2 (Figure 6-1) on the Isolator Board to the closed position (0).
3. Reinstall the top cover.

To select the S8 reading rate:

1. Remove the top cover.

#### WARNING

To prevent a shock hazard, remove the line cord and all test leads from the instrument before removing the top cover.

2. Set switch 2 (Figure 6-1) on the Isolator Board to the open position (1).
3. Reinstall the top cover.

### 6.5 CALIBRATION INTRODUCTION

Perform the following procedures and make the adjustments indicated to calibrate the Model 619 Electrometer/Multimeter, and the Model 6194 Electrometer Module(s). Calibration of the Model 6194 requires installation in a Model 619 main frame. Therefore, the following procedures include calibration of the module as part of the entire instrument. Calibration should be performed yearly (every 12 months) or whenever performance verification (see Section 3) indicates that the instrument is out of specification.

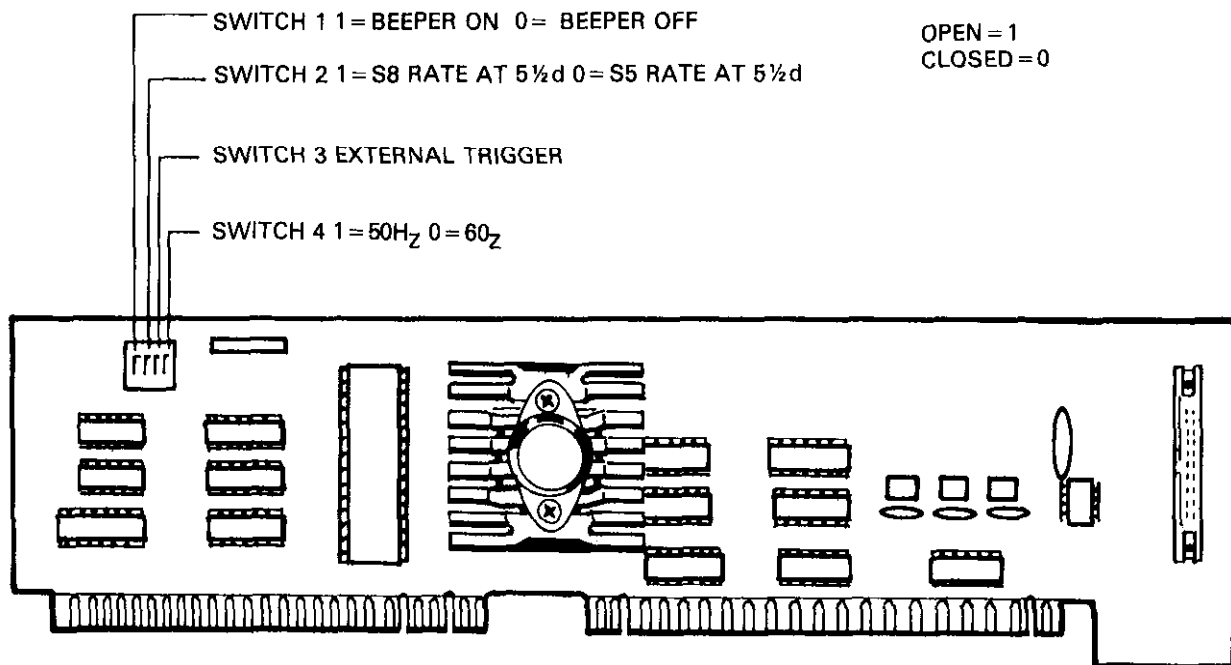

Figure 6-1. Isolator Board and Switches

## NOTE

Calibration of the Model 619 requires currents and impedances outside the ranges normally encountered in calibration laboratories. Due to the need for special handling, high level technical expertise, and non-standard test equipment, it is strongly recommended that the Model 619 be returned to the factory for service and/or calibration.

## 6.6 CALIBRATION/TEST EQUIPMENT AND CONDITIONS

### 6.6.1 Recommended Test Equipment and Related Information

Test equipment for calibration is listed in Table 6-2. Alternate test equipment may be used. However, the accuracy of the alternate test equipment must meet specifications listed below:

Voltage Sources ( $\pm 20$ ppm)

190.0000mV  
1.999999V  
19.99999V  
199.9999V

Current Sources ( $\pm 200$ ppm)

19.000mA  
190.00 $\mu$ A  
1.9000 $\mu$ A  
19.000nA

Calibration Resistance

19k $\Omega$   $\pm 100$ ppm  
19G $\Omega$   $\pm 1000$ ppm

## 6.7 INFORMATION AND ASSUMPTIONS

### 6.7.1 Standards

Maximum Allowable Input:

Input overload source must be noninductive with a capacitive component less than 5000pF.

Isolation:

Input LO to power line ground,  $> 100$ Mohm shunted by approximately 750pF. A/D Converter common to Electrometer Module Input,  $< 0.5$ pF.

Input Stability:

Stable with  $< 5000$ pF input to input common and/or guard (analog output in Volts or Ohms) and analog output to input common.

Ranging:

Manual or Automatic in Talk-Only mode.

Manual in Addressable mode.

Range exponents are multiples of three (0,  $\pm 3$ ,  $\pm 6$ ,  $\pm 9$ ,  $\pm 12$ ,  $\pm 15$ ,  $\pm 18$ ).

Weight:

Model 6194 Electrometer: 1lb. 12oz. (0.81kg)

Model 6193 IEEE-488 Interface: 6.5oz. (0.18kg)

Model 6191 Guarded Adapter: 5oz. (0.18kg)

Maximum Allowable Common Model Slew-Rate:

$10^9$  volts/sec., with no loss of data or commands across isolator.

Analog Output Characteristics:

Voltage:  $V_{out} = V_s \pm 1$ mV

Current:  $V_{out} = -(I_s \times R_{feedback}) \pm 1$ mV = 200mV F.S. on 2nA, 200nA, 20 $\mu$ A, 2mA ranges.

2 Volt F.S. on 20nA, 2 $\mu$ A, 200 $\mu$ A, 20mA ranges.

Resistance:  $V_{out} = R_s \times I_{sense} \pm 1$ mV (Output same as voltage across unknown. Refer to paragraph 6.6.1 for F.S. values.)

Output Resistance: 1kohm

Maximum Allowable Output Current: 1mA

Maximum Allowable Input Voltage (externally applied with respect to Analog Output common): 20 Volt peak.

## 6.8 VOLTS

Accuracy Specification Assume:

With input offset corrected by Zero Correct function after warm-up, and every 24 hours thereafter. Correct whenever  $|dT_a| > 1^\circ\text{C}$ . Spec exclusive of noise. Specified temperatures are package ambient. With  $> 1$  line period integration.

Temperature Coefficient Specifications Assume:

With source resistance  $< 100$ Mohm.

NMRR Specifications Assume:

$> 55$ dB valid with DC inputs up 90% of  $\pm$  full scale.

Rating based on 1 digit injection on 2 Volt through 200 Volt ranges and 4 digits injection on 200mV range.

At 50 and 60Hz, max. rdg rate, with 1 line-period integration.

Filtering adds 25dB.

CMRR Specifications Assume:

$> 100$ dB valid for 200mV and 2 Volt ranges. Rating decreases to 80dB for 20 Volt range and 60dB for 200 Volt range.

At DC, 50, and 60Hz with 1kohm unbalance, max. rdg rate, 1 line-period integration.

Analog Settling Time Specifications Assume:

Exclusive of input noise, with less than 1mA of total resistive and dV/dT capacitive analog output load (max. capacitance 5000pf).

Exclusive of source response time and A/D conversion time. Refer to Model 619 Systems Use Specifications for digitization times.

Input Noise: 20 $\mu$ V p-p Assuming:

With source resistance  $< 100$ Mohm. Over 1 minute, unfiltered, self-generated.

**Table 6-2. Recommended Test Equipment**

Item	Description	Output	Accuracy	Mfr.	Model	
A	DC Calibration	1.999999V 19.99999V 199.9999V	0.002% or 20ppm	Fluke	343A	1
B	Current Source	10 $\mu$ A-2A	0.01%	Valhalla	2500	1
C	Decade Resistor	120k $\Omega$ /10k-Step S 110M $\Omega$ /1M-Step S	50ppm 50ppm	ESI	SR-1010 SR-1050	1 1
D	R-289-10G Resistor	10G $\Omega$	1000ppm	K-I		2
E	R-289-100G Resistor	100G $\Omega$	1000ppm	K-I		1
F	Ohms Calibration	10 <sup>6</sup> -10 <sup>13</sup>		Guideline	9520	1

**6.9. AMPS**

External Feedback has the following specifications:

RANGE	MAXIMUM READING	ACCURACY $\pm$ year, 23 $^{\circ}$ $\pm$ 5 $^{\circ}$ C $\pm$ (%rdg + digits)	TEMPERATURE COEFFICIENT 0-18 $^{\circ}$ C and 28-50 $^{\circ}$ C $\pm$ (% rdg + digits)/ $^{\circ}$ C
External Feedback (9)	1.9999 (volts)	0.01% + 1d	0.002% + 0.3d

Input, NMRR, Noise, and Analog Settling Times will be a function of the feedback element. Displayed reading is the voltage across the External Feedback element.

**Accuracy Specifications Assume:**

With input offset corrected by Zero Correct function after warmup and every 24 hours thereafter. Correct whenever  $dT_a > 1^{\circ}$ C. Spec exclusive of noise. Specified temperatures are package ambient. With  $> 1$  line-period integration.

**NMRR Specifications Assume:**

Valid with DC inputs up to 90% of  $\pm$  full scale. At 50 and 60Hz, max. rdg rate, with 1 line-period integration. Filtering adds 25dB.

**Analog Settling Time Specifications Assume:**

With less than 1mA of total resistive and dV/dT capacitive analog output load (max. capacitance 5000pF). Exclusive of source response time and A/D conversion time. Refer to Model 619 System Use Specifications for digitization times.

External Feedback range requires user supplied feedback element for current to voltage conversion (resistor), charge to voltage conversion (capacitor), etc. Accuracy, Temperature Coefficient specifications are in addition to (but not including) that of feedback element. Feedback element is connected from the Analog Output to the Module

Input Noise:

2 $\mu$ A : 5d  
20 $\mu$ A: 0.5d  
200 $\mu$ A, 20 $\mu$ A, 2 $\mu$ A, 2A : 2d  
2 $\mu$ A, 200 $\mu$ A, 20 $\mu$ A : 0.3d  
External Feedback : 0.3d

Digits, peak to peak, over 1 minute, unfiltered, self-generated, 4 1/2 digit readout.

Input Voltage Drop:

Whenever a series connected voltage source and resistor are used to calibrate, or verify the Model 619 Amps range, the effect of the input voltage drop must be taken into account. From the specifications the maximum value of 1mV will constitute an uncertainty in the effective accuracy of the voltage source. Maintaining this source at voltage levels > 1.9V will reduce this uncertainty to < 0.05%.

## 6.10 OHMS

Accuracy Specifications Assume:

With input offset corrected by Zero Correct function after warm-up and every 24 hours thereafter. Correct whenever  $dT_a > 1^\circ\text{C}$ . Spec exclusive of noise. Specified temperatures are package ambient.

With > 1 line-period integrations.

External voltage sources < 50 $\mu$ V.

## 6.11 ENVIRONMENTAL CONDITIONS

Calibration should be performed under laboratory conditions having an ambient temperature of  $23^\circ \pm 1^\circ\text{C}$ , and a relative humidity of less than 70%. If the instrument has been subjected to temperatures outside of this range, or to higher humidity, allow one hour minimum for the instrument to stabilize at the specified environmental conditions before beginning the calibration procedure.

## 6.12 CALIBRATION

### NOTE

When calibrating Channel B, paragraph 6.14, do not repeat steps 2 and 3 of same paragraph.

In order to reduce the response time induced by stray capacitance, the Model 6191 Guarded Input Adapter could be used for reduced input cable effect (see paragraph 3.2). The internal short across the 10M $\Omega$  resistor must be in place when using the Model 6191 for calibration.

## 6.13 CALIBRATION COVER INSTALLATION

Calibration should be performed using the Model 6195 Calibration Cover (see Figure 6-2). This cover permits access to Model 619 and to Model 6194 adjustments, while allowing the instrument to reach normal internal operating temperature. Install the cover as follows:

### WARNING

**To prevent a shock hazard, remove the line cord and all test leads from the instrument before removing the top cover.**

1. Turn the power off and disconnect the line cord.
2. Remove the two screws holding the top cover. These screws are located on the rear panel.
3. Grasping the top cover at the rear, carefully lift it off the instrument.
4. Install the Calibration Cover on the Model 619.

## 6.14 CALIBRATION ADJUSTMENTS

The sequence of calibration adjustments is as follows:

1. Input amplifier zero.
2. A/D reference supply calibration.
3. Multiplier calibration.
4. Amps calibration.
5. Ohms reference calibration.

Perform the following procedures and make the adjustments indicated to calibrate the Model 619. The location of the calibration pots is indicated on the Model 6195 Calibration Cover (see Figure 6-2).

1. Input Amplifier Zero: Place the instrument in Zero Check, Channel A, Volts, and Manual ranging. Should the instrument have only one Electrometer module, it must be located in position A (Channel A). Set the Model 619 to the 200mV range and adjust R656 for a display reading of 0.00 -3 within  $\pm 1$  count.

### NOTE

Zero Correct should not be used prior to this step.

2. 200mV A/D Reference Supply Calibration: Using the DC Calibrator and 10:1 divider, apply +190.00mV to the input of the Electrometer. After actuating the Zero Correct, release the Zero Check and adjust R411 for a display reading of +190.00 -3 to within  $\pm 1$  count. Refer to Figure 6-3.
3. 2 Volt A/D Reference Supply Calibration: Uprange the Model 619 to the 2 Volt range, and apply +1.9000 Volts to its input. Adjust R415 for a display reading of +1.9000 +0 to within  $\pm 1$  count. Refer to Figure 6-4.

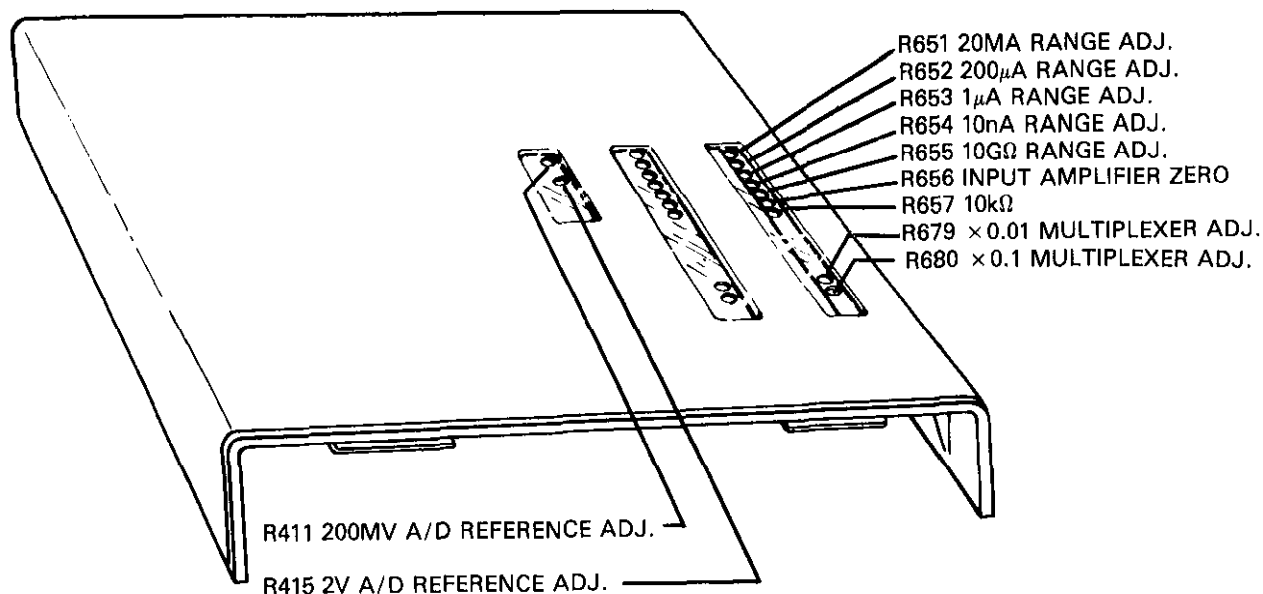

Figure 6-2. Calibration Cover

4. X0.1 Multiplier Calibration: Uprange the Model 619 to the 20 Volt range and apply + 19.000 Volts to its input. Adjust R680 for a display of + 19.000 +0 to within  $\pm 1$  count.
5. X0.01 Multiplier Calibration: Uprange the Model 619 to the 200 Volt range and apply + 190.00 Volts to its input. Adjust R679 for a display reading of + 190.00 +0 to within  $\pm 1$  count.
6. 20mA Range Calibration: Zero Check the Model 619 and set it to the Amps function. Uprange to the 20mA range and verify a display reading of 19.000 -3 using Zero Correct if necessary. Release Zero Check and apply a + 19.000mA input, adjust R651 for a display reading of 19.000 -3 to within  $\pm 2$  counts. Refer to Figure 6-5.
8. 2 $\mu$ A Range Calibration: Zero Check the Model 619 and downrange to the 2 $\mu$ A range. Apply + 1.9000 $\mu$ A to the input of the Model 619, release the Zero Check and adjust R653 for a display reading of + 1.9000 -6 to within  $\pm 1$  count.
9. 20nA Range Calibration: Zero Check the Model 619 and downrange to the 20nA range. Apply + 19.000nA to the input of the Model 619, release the Zero Check and adjust R654 for a display reading of + 19.000 -9 to within  $\pm 2$  counts. Refer to Figure 6-6.
10. 20k $\Omega$  Range (Ohms Reference) Calibration: Zero Check the Model 619 and set the Ohms function. Select the 20k $\Omega$  range and verify a display reading of 0.000 +3 using Zero Correct if necessary. Connect the 19k $\Omega$  Calibration Resistor to the input of the Model 619, release the Zero Check and adjust R657 for a display reading of 19.000 +3 to within  $\pm 1$  count. Refer to Figure 6-7.

**NOTE**

For a valid Zero Check reading the input current must be less than 100 $\mu$ A.

**NOTE**

Select the 19G $\Omega$  precision resistor using equipment with accuracy traceable to National Bureau of Standards Laboratory. The resistance value should be determined to within 1000ppm.

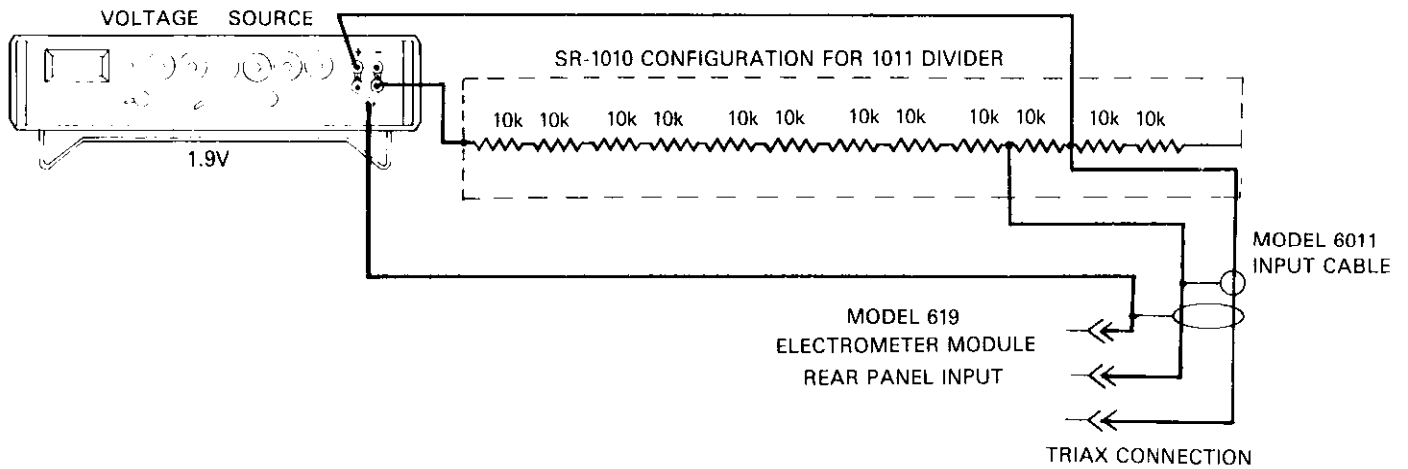

Figure 6-3. Supply Calibration .200mV

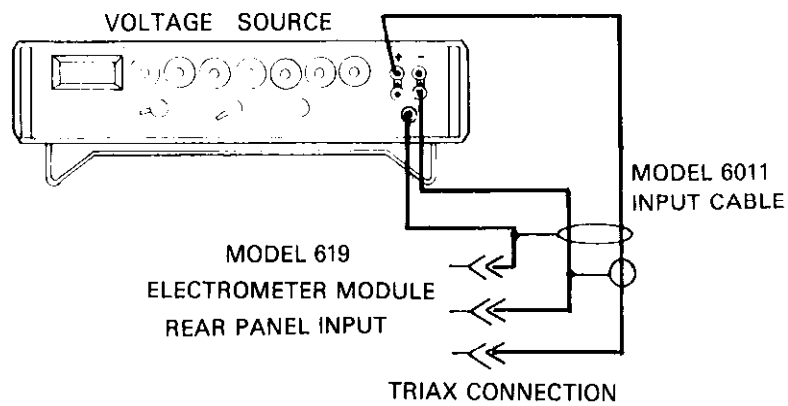

Figure 6-4. Supply Calibration 2 Volt

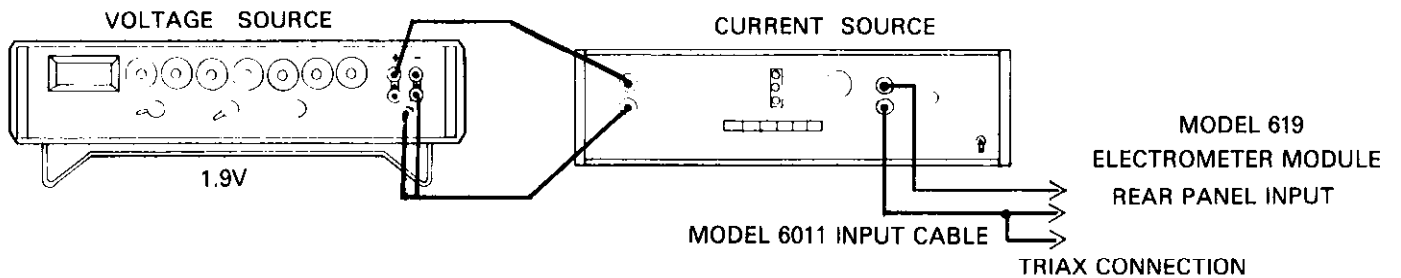

Figure 6-5. Range Calibration 20mA

11. 20GΩ Range Calibration: Calibrate the 20GΩ range see Figure 6-8. Zero Check the Model 619 and uprange to the 20GΩ range. Connect the 19GΩ Calibration Resistor to the input of the Model 619, release the Zero Check, and adjust R655 for a display reading of 19.000 +9 to within ±15 counts.
12. Range Verification: After range calibration perform the verification procedures. Refer to Section 3 for these procedures.
13. Channel B Calibration: If a Channel B Electrometer is installed in the Model 619, Steps 1 and 4 through 12 must be repeated for this channel.

### 6.15 CALIBRATION FIXTURE

The required calibration fixture uses a source of 19GΩ. Its resistors must be accurate to 1000ppm.

1. The following items are necessary for proper calibration:
  - A. 2 10.0GΩ resistors, Keithley part number R-289-10G.
  - B. 1 100.0GΩ resistor, Keithley part number R-289-100G.
  - C. 2 enclosed chassis boxes one to be placed inside the other and insulated from each other.
  - D. 1 triax connector, Keithley part number CS-181.
  - E. 1 banana jack, Keithley part number BJ-11.
  - F. 1 6191 Guarded Input Adapter.
  - G. 7024-1 triax cable (1 ft long, male to male connector).

#### NOTE

Do not repeat Steps 2 and 3.

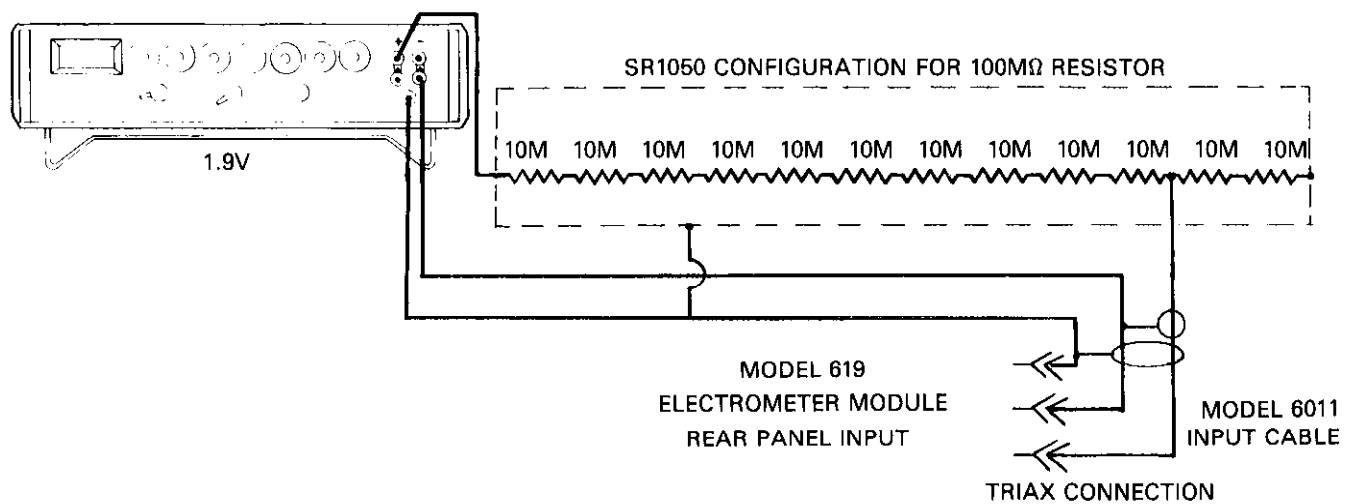

Figure 6-6. Range Calibration, 20nA

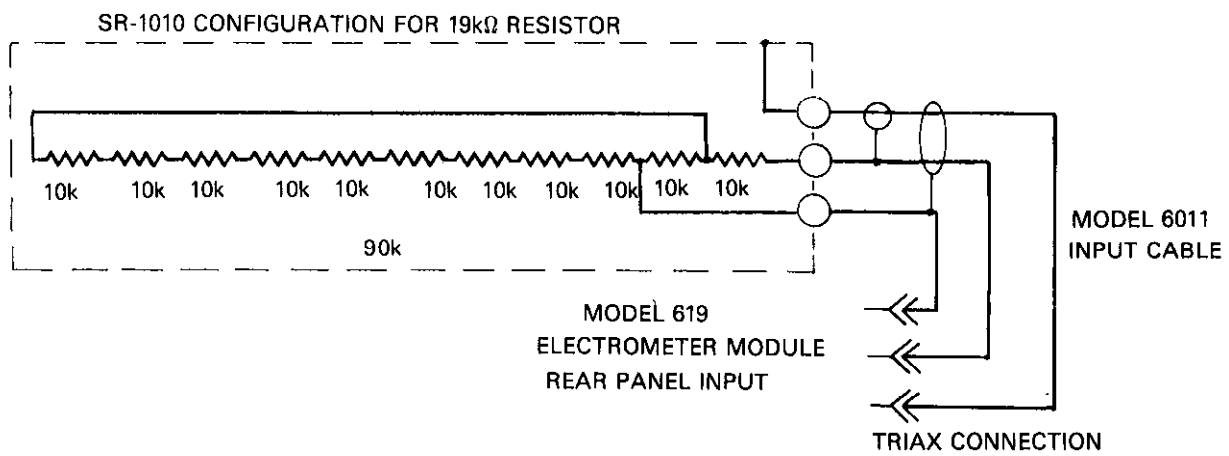

Figure 6-7. Range Calibration 20kΩ

### NOTE

Possible sources of high value resistors are: Dale Electronics, Inc., Columbus, Nebraska Victoreen, Cleveland, Ohio K & M Electronics, West Springfield, Massachusetts.

2. Refer to Figure 6-9 for a schematic of the calibration fixture.

### 6.16 CONSTRUCTION INFORMATION

1. To decrease settling time and to assure accurate calibration, an internal guard is recommended (see Figure 6-9). The guard must be isolated from the surrounding case.
2. To further minimize inaccuracies, current leakage paths to ground (or guard) must be minimized. This requires the use of low leakage insulating materials (such as Teflon®) for construction and the use of special cleansing agents (such as Freon) to clean the components and insulators after construction.

### 6.17 CALIBRATION of 1.9GΩ SOURCE

Connect the 19GΩ source to a teraohmmeter. A meter with acceptable accuracy is listed in Recommended Test Equipment, Table 6-2). Determine the value to within  $\pm 1000$  ppm. This must be done at a temperature of  $23^{\circ}\text{C} \pm 1^{\circ}\text{C}$ .

Once the value of the 19GΩ source has been established, it may be used (for calibration) for a limited time. The stability specifications of the resistors used will determine the length of time the 19GΩ source can be used. After this time, the exact value of the 1.9GΩ source must again be determined. The teraohmmeter can be used to re-establish the value.

### 6.18 TROUBLESHOOTING

The troubleshooting information in this section is intended for use by qualified personnel who have a basic understanding of the analog and digital circuitry used in a precision test instrument. Instructions have been written to assist in isolating the defective circuit. Isolating the defective component has been left to the troubleshooter.

### NOTE

For instruments that are still under warranty (less than 12 months since date of shipment), whose performance is outside of specifications at any point, contact your Keithley representative or the factory before attempting troubleshooting or repair other than battery or fuse replacement.

#### 6.18.1 Special Handling of Static Sensitive Devices

CMOS devices are designed to function at high impedance levels. Normal static charge can destroy these devices. Table 6-3 lists all the static sensitive devices for the Model 619. Steps 1 through 7 provide instruction on how to avoid damaging these devices.

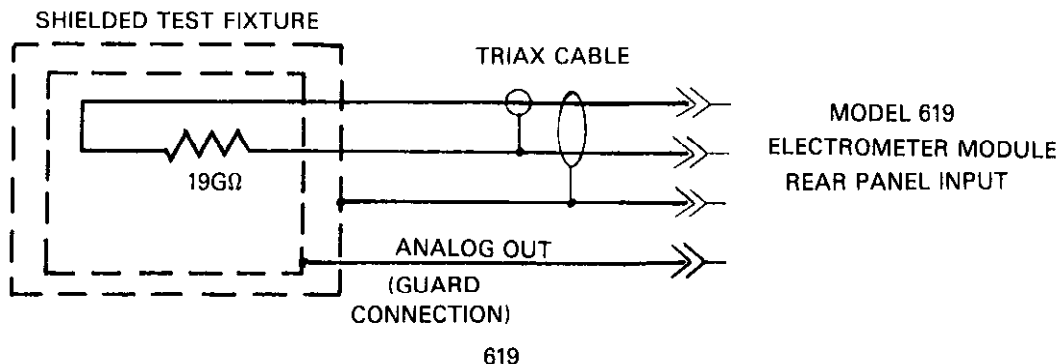

Figure 6-8. Range Calibration, 20GΩ



**Table 6-3. Static Sensitive Devices**

Reference Designation	Keithley Part Number
U202	IC-141
U204, U207	
U807	LSI-28
U905	LSI-27
U906	PRO-114-*
U907, U915, U924	PRO-115-*
U913	LSI-26
U919, U920, U922, U923	LSI-15

1. Devices should be handled and transported in protective containers, antistatic tubes or conductive foam.
2. Use a properly grounded work bench and a grounding wriststrap.
3. Handle device by the body only.
4. PCB's must be grounded to bench while inserting devices.
5. Use antistatic solder suckers.
6. Use grounded tip soldering irons.
7. After devices are soldered or inserted into sockets they are protected and normal handling can resume.

### 6.18.2 Troubleshooting Procedure

1. General Procedure
  - A. Turn the Model 619 ON.
  - B. Observe the proper indication on the display.
    - (a) Initially the display is blank and the beeper sounds for approximately two seconds.
    - (b) Display shows line frequency and level of the software e.g. F60 C-1.
    - (c) The Model 619 ends up in the default conditions e.g. Volts, Channel A, Zero Check.
  - C. Visually inspect all PC Boards to verify that they are properly seated in the connectors.
2. Power Supply Checks
  - A. J305 pins 1,2,3,4 referenced to analog common has 33VAC  $\pm 5\%$ .
  - B. J305 pin 8 referenced to analog common has +15V  $\pm 5\%$ .
  - C. J305 pin 9 referenced to analog common has -15V  $\pm 5\%$ .
  - D. J305 pin 10, 11 and 12 referenced to analog common has +5V  $\pm 5\%$ .
  - E. J304 pins 6,7,8 and 9 referenced to analog common has +9.5V  $\pm 5\%$ .
  - F. Check each PC Board for appropriate voltage as shown on the schematic diagram.

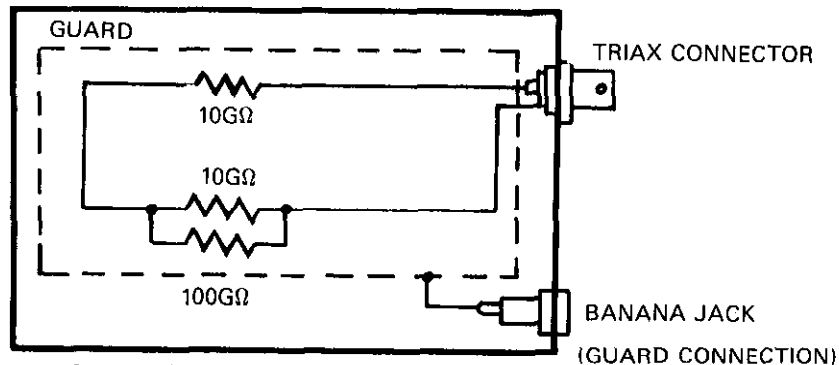

**Construction notes:**

1. To decrease settling times and to assure accurate calibrations, it is recommended to use an internal guard (as shown in the drawing above). The guard must be insulated from the surrounding case.
2. To further minimize inaccuracies, current leakage paths to ground (or guard) must be minimized. This requires the use of low leakage insulating materials (switches) for construction and the use of special cleansing agents such as freon<sup>®</sup> to clean the components and insulators after construction.

**Figure 6-9. Calibration Fixture Schematic Diagram**

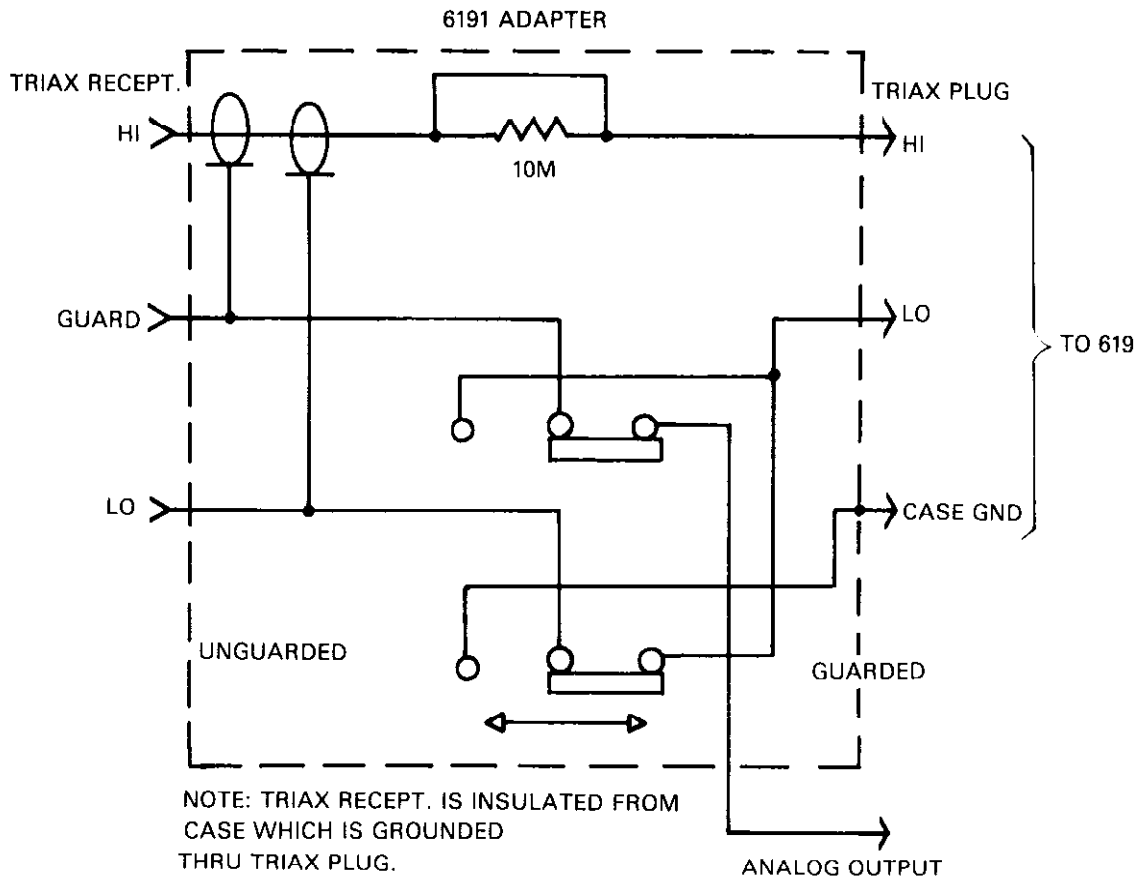

**Figure 6-10. Model 6191 Guarded Adapter**

**3. Clock Checks**

- A. CPU Board (PC-518), U905 pins 38 and 39 has 4MHz at a TTL level.
- B. A/D Board (PC-520) Y501 has 4.915MHz. U516 divides this frequency to 307.2kHz (U516 pin 7) and 614.4kHz (U516 pin 6).

**4. Logic Section Checks (CPU Board)**

- A. Verify data transfer from chip to chip.
- B. Verify address logic and timing.

**5. Isolator and Filter Mux Boards**

- A. Verify data transfer through the opto isolators AT1-AT4 on the Isolator Board.
- B. Check various voltages on the Filter Mux Board as shown in the schematic diagram.
- C. Check operation of Channel A and Channel B relays.

**6. A/D Converter Checks**

- A. Check signal paths from the Filter Mux Board to the A/D Board.

- B. Check Integrator Output (U506 pin 2) as shown in Figure 6-11 Integrator output waveform.

**7. Electrometer Checks**

- A. Check feedback loops of U651.
- B. Check switching order of feedback loops.
- C. Check bootstrap supplies (Test Points).

**8. Front Panel Operation**

It is important to check the front panel operation because it will help to isolate the problem as a result of the read out on the display.

**6.19 Fan Filter Cleaning**

The Fan Filter must be kept clean. Dirt in the filter will impede the air flow through the Model 619 and cause overheating. It is recommended to periodically remove the filter (FL-3) and use compressed air to clean it.

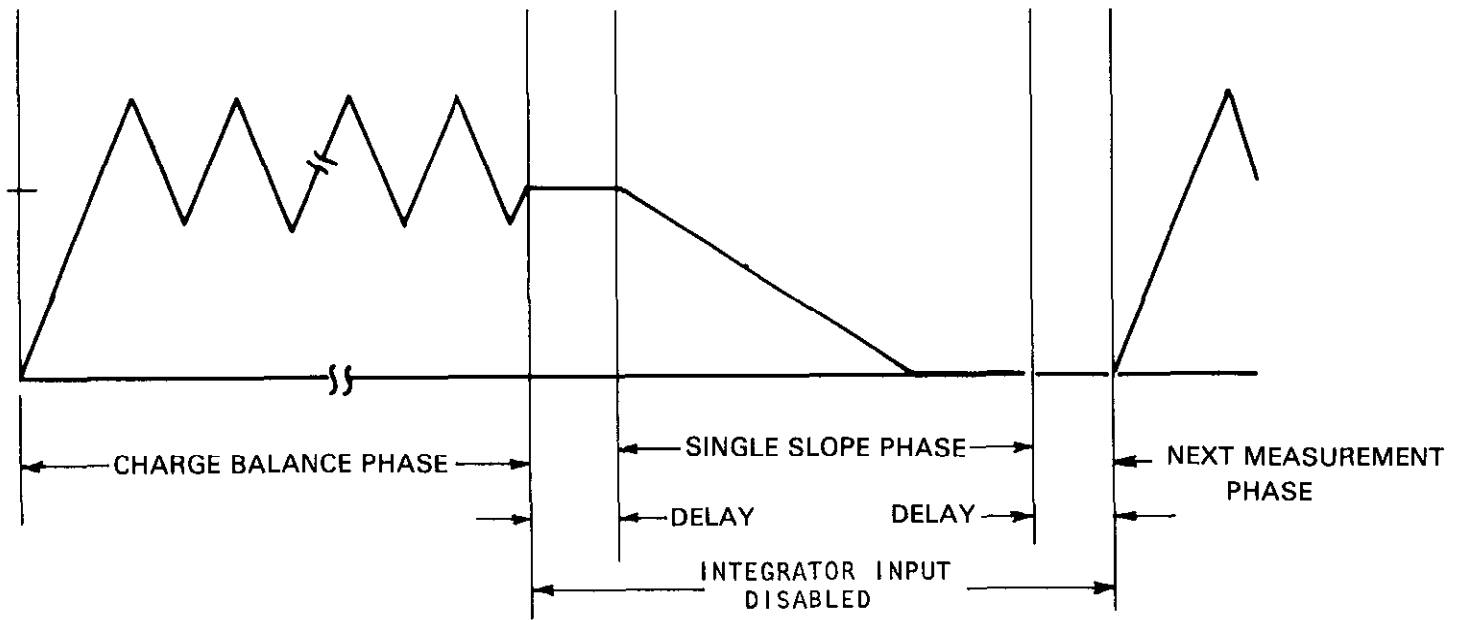

Figure 6-11. Integrator Output Waveform

## **SECTION 7**

### **REPLACEABLE PARTS**

#### **7.1 INTRODUCTION**

This section contains replacement parts information, component location drawings and schematic diagram for the Model 619. A cross-reference list of manufacturers is also provided (see Table 7-1).

#### **7.2 PARTS LIST**

Parts are listed alphabetically in order of their circuit designations. Table 7-2 contains parts list information for the Display Board PC-514. Table 7-3 contains parts list information for the Power Supply PC-515. Table 7-4 contains IEEE Interface PC-517 parts list information. Table 7-5 provides parts list information for the CPU Board PC-518; while Table 7-6 contains parts list information for the Isolator Board. Parts list information for the A/D Converter PC-520 is presented in Table 7-7. Parts list information for the Electrometer Module PC-523 and PC-522 are provided in Table 7-8. Table 7-9 contains parts list information for the Filter Mux Board PC-521. Table 7-10 provides parts list information for the Fan assembly.

#### **7.3 ORDERING INFORMATION**

To place an order, or to obtain information concerning replacement parts, contact your Keithley representative or the factory. See inside front cover for addresses. When ordering include the following information:

1. Instrument Model Number
2. Instrument Serial Number
3. Part Description
4. Circuit Description (if applicable)
5. Keithley Part Number

#### **7.4 FACTORY SERVICE**

If the instrument is to be returned to the factory for service, please complete the service form which follows this section and return it with the instrument.

#### **7.5 SCHEMATIC DIAGRAMS AND COMPONENT LOCATION DRAWINGS**

Schematic diagrams and component location drawings follow the replaceable parts list information contained in this section.

1. Component Location drawings for the Model 619 are as follows:
  - A. Figure 7-1. Mother Board 30411C
  - B. Figure 7-2. Display Board 32003D
  - C. Figure 7-3. Power Supply Board 32004D
  - D. Figure 7-4. IEEE Interface Board 30329D
  - E. Figure 7-5. Processor Board 32005D
  - F. Figure 7-6. Isolator Board 32006D
  - G. Figure 7-7. A/D Converter Board 30395D
  - H. Figure 7-8. Electrometer Module Board 30387D and 30391D
  - I. Figure 7-9. Filter Mux Board 30352D
2. Schematic diagrams for the Model 619 are as follows:
  - A. Figure 7-10. Mother Schematic 30517D
  - B. Figure 7-11. Display Schematic 30515D
  - C. Figure 7-12. Power Supply Schematic 30516D
  - D. Figure 7-13. IEEE Interface Schematic 30518D
  - E. Figure 7-14. Processor Schematic (CPU) 30519D
  - F. Figure 7-15. Isolator Schematic 30520D
  - G. Figure 7-16. A/D Converter Schematic 30521D
  - H. Figure 7-17. Electrometer Module Schematic 30522D and 30523D
  - I. Figure 7-18. Filter Mux Schematic 30524D

**Table 7-1. Cross-reference List of Manufacturers**

MFR. CODE	NAME AND ADDRESS	FEDERAL SUPPLY CODE	MFR. CODE	NAME AND ADDRESS	FEDERAL SUPPLY CODE
A-B	Allen-Bradley Corp. Milwaukee, WI 53204	01121	F-I	Fairchild Instruments Mountain View, CA 94043	07263
A-D	Analog Devices, Inc. Norwood, MA 02026	24355	G-E	General Electric Co. Syracuse, Ny 13201	03508
ACI	American Components, Inc. Conshohocken, PA 19423	14298	GRH	Grayhill, Inc. La Grange, IL 60525	81073
AMP	Amphenol Broadview, IL 60153	02660	H-P	Hewlett-Packard Co. Palo Alto, CA 94304	50444
BEC	Beckman Instruments, Inc. Fullerton, CA 92634	73188	INT	Intersil, Inc. Cupertino, CA 95014	32293
BRG	Berg Electronic, Inc. New Cumberland, PA 17070	22526	ITT	ITT Semiconductor Lawrence, MA 01841	15238
BOM	Bomar Crystal Co. Middlesex, NJ 08846	--	K α M	K α M Electronics Co. Minneapolis, MN 55435	--
BRN	Bourns, Inc. Riverside, CA 92507	80294	K-I	Keithley Instruments, Inc. Cleveland, Ohio, 44139	80164
C-I	Components, Inc. Biddeford, ME 04005	06751	L-F	Little Fuse, Inc. Des Plaines, IL 60016	75915
C α K	C α K Components, Inc. Watertown, MA 02158	09353	MAL	Mallory Indianapolis, IN 46206	90201
CAD	Caddock Riverside, CA 92507	19647	MEP	Mepco, Inc. Morristown, NJ 07960	80031
CLB	Centralab Division Milwaukee, WI 53201	71590	MMM	3M Company St. Paul, MN 55101	--
COC	Corcom Chicago, IL 60639	05245	MOL	Molex Downers Grove, IL 60515	27264
COT	Coto-Coil Co., Inc. Providence, RI 02905	71707	MON	Monsanto St. Louis, MO 63122	76541
COW	Continental Wirt Warminster, PA	79727	MOT	Motorola Semi Products, Inc. Phoenix, AZ 85008	04713
CTS	CTS Corporation Elkhart, IN 46514	71450	MUR	Murata Corp. of America Elmsford, NY 10523	51406
DLE	Dale Electronics Columbus, NE 68601	91637	NAT	National Semi Corp. Santa Clara, CA 94086	27014
ECI	Electro-Cube, Inc. San Gabriel, CA 91776	14752	NEC	NEC Microcomputer, Inc. Lexington, MA 02173	--
EDI	Electronic Devices, Inc. Yonkers, NY 10710	83701	NIC	Nichicon Corp. Chicago, IL 60645	--
EMC	EMC Industries, Inc. Hatboro, PA 19040	50417	NYT	Nytronics Components Group Darlington, SC 29532	83125
ERI	Erie Technological Prod. Erie, PA 16512	72982	PAT	Pattison Supply Co. Cleveland, OH 44125	--

**Table 7-1. Cross-reference List of Manufacturers (Cont.)**

MFR. CODE	NAME AND ADDRESS	FEDERAL SUPPLY CODE	MFR. CODE	NAME AND ADDRESS	FEDERAL SUPPLY CODE
POM	Pomona Electric Pomona, CA 91766	05276	SUP	Superior Electric Bristol, CT 06010	58474
PRP	Precision Resistive Products Mediapolis, IA 53237	--	SYN	Synertek Santa Clara, CA 95051	--
RCA	RCA Corporation Moorestown, NJ 08050	02734	T-I	Texas Instruments, Inc. Dallas, TX 75231	01295
RIC	Richey Nashville, TN 37207	29309	TEL	Teledyne Mountain View, CA 94040	15818
SCH	Schuster Electric Co. Cincinnati, OH 45242	--	TRW	TRW Elect. Component IRC Boone, NC 28607	11502
SIE	Siemens Corp. Iselin, NJ 08830	25088	UCC	United Chemico-Con, Inc. Rosemont, IL 60013	--
SIG	Sigmetics Corp. Sunnyvale, CA 94086	13324	VIC	Victoreen Instruments Co. Cleveland, OH 44193	63060
SPG	Sprague Electric Co. Visalia, CA 93278	14659			

**Table 7-2. Display Board PC-514 Parts List**

Circuit Desig.	Description	Schematic Location	PC-Board Item No./Location	Mfr. Code	Mfr. Desig.	Keithley Part No.
C201	.1 $\mu$ F, 50v, CerF	514/B1	3/G2	ERI	8121-M050 651-104M	C-237-.1
C202	.1 $\mu$ F, 50V, CerF	514/B1	4/D3	ERI	8121-M050 651-104M	C-237-.1
C203	.1 $\mu$ F, 50V, CerF	514/B1	5/C3	ERI	8121-M050 651-104M	C-237-.1
C204	33 $\mu$ F, 10V, Tant	514/A1	6/C3	C-I	TSD 3-10 336-PCM 1287	C-180-33
C205	.1 $\mu$ F, 50V, CerF	514/B1	7/D3	ERI	8121-M050 651-104M	C-237-.1
C207	.1 $\mu$ F, 50V, CerF	514/B1	9/B4	ERI	8121-M050 651-104M	C-237-.1
C208	1000pF, CerD	514/F4	10/H3	ERI	801Z, 5V 472M	C-64-1000p
DS201	Digital Display $\pm$ 1	514/E1	14/A2	F-I	FND5102	DD-21
DS202	8 Segment Display	514/E1	15/A2	F-I	FND5101	DD-20
DS203	8 Segment Display	514/F1	16/A2	F-I	FND5101	DD-20
DS204	8 Segment Display	514/F1	17/B2	F-I	FND5101	DD-20
DS205	8 Segment Display	514/F1	18/B2	F-I	FND5101	DD-20
DS206	8 Segment Display	514/F1	19/B2	F-I	FND5101	DD-20
DS207	Digital Display $\pm$ 1	514/G1	20/C2	F-I	FND5102	DD-21
DS208	8 Segment Display	514/G1	21/C2	F-I	FND5101	DD-20
DS209	LED, Red	514/F4	22/C2	MON	MV5753	PL-67
DS210	LED, Red	514/F3	23/C3	MON	MV5753	PL-67
DS211	LED, Red	514/F3	24/C2	MON	MV5753	PL-67
DS212	LED, Red	514/H2	25/A3	MON	MV5753	PL-67
DS213	LED, Red	514/F4	26/B3	MON	MV5753	PL-67
DS214	LED, Red	514/G4	27/C3	MON	MV5753	PL-67
DS215	LED, Red	514/H1	28/A3	MON	MV5753	PL-67
DS216	LED, Red	514/F3	29/B3	MON	MV5753	PL-67
DS217	LED, Red	514/G3	30/C3	MON	MV5753	PL-67

**Table 7-2. Display Board PC-514 Parts List (Cont.)**

Circuit Desig.	Description	Schematic Location	PC-Board Item No./Location	Mfr. Code	Mfr. Desig.	Keithley Part No.
DS218	LED, Red	514/H2	31/A3	MON	MV5753	PL-67
DS219	LED, Red	514/F3	32/B3	MON	MV5753	PL-67
DS220	LED, Red	514/G3	33/C3	MON	MV5753	PL-67
DS221	LED, Red	514/H1	34/A3	MON	MV5753	PL-67
DS222	LED, Red	514/F4	35/B3	MON	MV5753	PL-67
DS223	LED, Red	514/G4	36/C3	MON	MV5753	PL-67
DS224	LED, Red	514/F3	37/B3	MON	MV5753	PL-67
DS225	LED, Red	514/G3	38/C3	MON	MV5753	PL-67
DS226	LED, Red	514/F3	39/B4	MON	MV5753	PL-67
DS227	LED, Red	514/G3	40/C4	MON	MV5753	PL-67
DS228	LED, Red	514/G3	41/B4	MON	MV5753	PL-67
DS229	LED, Red	514/H3	42/C4	MON	MV5753	PL-67
LS201	Buzzer	514/F4	51/H3	MUR	PM12-6A0	EM-3
R201	10k, 5%, 1/4W, Comp	514/C5	55/D2	A-B	EB	R-76-10k
R202	10k, 5%, 1/4W, Comp	514/D5	56/E2	A-B	EB	R-76-10k
R203	10k, 5%, 1/4W, Comp	514/D5	57/F2	A-B	EB	R-76-10k
R204	10k, 5%, 1/4W, Comp	514/E5	58/G2	A-B	EB	R-76-10k
R205	10k, 5%, 1/4W, Comp	514/F4	59/H2	A-B	EB	R-76-1.5M
R206	47, 10%, 1/2W, Comp	514/D1	60/A3	A-B	EB	R-1-47
R207	47, 10%, 1/2W, Comp	514/D1	61/A3	A-B	EB	R-1-47
R208	47, 10%, 1/2W, Comp	514/C1	62/A3	A-B	EB	R-1-47
R209	47, 10%, 1/2W, Comp	514/D1	63/A3	A-B	EB	R-1-47
R-210	47, 10%, 1/2W, Comp	514/D	64/B3	A-B	EB	R-1-47
R211	47, 10%, 1/2W, Comp	514/E1	65/B3	A-B	EB	R-1-47
R212	47, 10%, 1/2W, Comp	514/D1	66/A3	A-B	EB	R-1-47
R213	47, 10%, 1/2W, Comp	514/D1	67/A3	A-B	EB	R-1-47
R214	47, 10%, 1/2W, Comp	514/E3	68/A3	A-B	EB	R-1-47



**Table 7-2. Display Board PC-514 Parts List (Cont.)**

Circuit Desig.	Description	Schematic Location	PC-Board Item No./Location	Mfr. Code	Mfr. Desig.	Keithley Part No.
R215	47, 10%, 1/2W, Comp	514/E3	69/A3	A-B	EB	R-1-47
R216	47, 10%, 1/2W, Comp	514/E3	70/B3	A-B	EB	R-1-47
R217	4.7k, 5%, 1/4W, Comp	514/E3	71/C3	BRN	CR25, 4.7k, 1%, 1/4w	R-76-4.7k
R218	4.7k, 5%, 1/4W, Comp	514/E3	72/C3	BRN	CR25, 4.7k 10%, 1/4w	R-76-4.7k
R219	4.7k, 5%, 1/4W, Comp	514/E3	73/C3	BRN	CR25, 4.7k 10% <sub>m</sub> , 1.4W	R-76-4.7k
R220	68k, 5%, 1/4W, Comp	514/E2	74/C3	BRN		R-76-68K
S201	Switch, Pushbutton	514/C5	81/D2	SCH	MDP	SW-435
S202	Switch, Pushbutton	514/D5	82/E2	SCH	MDP	SW-435
S203	Switch, Pushbutton	514/D5	83/F2	SCH	MDP	SW-435
S204	Switch, Pushbutton	514/E5	84/G2	SCH	MDP	SW-435
S205	Switch, Pushbutton	514/C5	85/D2	SCH	MDP	SW-435
S208	Switch, Pushbutton	514/E5	88/G2	SCH	MDP	SW-435
S210	Switch, Pushbutton	514/D5	90/E3	SCH	MDP	SW-435
S211	Switch, Pushbutton	514/E5	91/F3	SCH	MDP	SW-435
S212	Switch, Pushbutton	514/E5	92/G3	SCH	MDP	SW-435
S213	Switch, Pushbutton	514/C5	93/D3	SCH	MDP	SW-435
S216	Switch, Pushbutton	514/E5	96/G3	SCH	MDP	SW-435
S217	Switch, Pushbutton	514/C6	97/D3	SCH	MDP	SW-435
S218	Switch, Pushbutton	514/D6	98/E3	SCH	MDP	SW-435
S219	Switch, Pushbutton	514/D6	99/F3	SCH	MDP	SW-435
S220	Switch, Pushbutton	514/E6	100/G4	SCH	MDP	SW-435

**Table 7-2. Display Board PC-514 Parts List (Cont.)**

Circuit Desig.	Description	Schematic Location	PC-Board Item No./Location	Mfr. Code	Mfr. Desig.	Keithley Part No.
S224	Switch, Pushbutton	514/E6	104/G4	SCH	MDP	SW-435
U201	Segment/Digit Driver	514/S1V	111/D2	T-1	75492	IC-141
U202	Hex Inverter	514/F4	112/H2	MOT	4049	IC-106
U203	Segment/Digit Driver	514/C3	113/B3	T-1	75492	IC-206
U204	PIA	514/B2	114/B3	MOT	406821P	LS1-8
U205	Segment/Digit Driver	514/C2	115/C3	T-1	75492	IC-206
U206	Segment/Digit Driver	514/C2	116/D3	T-1	75492	IC-169
U207	PIA	514/B4	117/D3	MOT	406821P	LS1-8

**Table 7-3. Power Supply PC-515 Parts List**

Circuit Desig.	Description	Schematic Location	PC-Board Item No./Location	Mfr. Code	Mfr. Desig.	Keithley Part No.
C301	.01 $\mu$ F, 500V, CerD	515/D5	3/C5	SPG	871-Z5U0 103M	C-22-.01
C302	11600 $\mu$ F, 25V, Alum Elect	515/E4	4/C5	RIC	HC9-11-11600 25-8P	C-314-11600
C303	11600 $\mu$ F, 25V, Alum Elect	515/E4	5/C5	RIC	HC9-11-11600 25-8P	C-314-11600
C304	10 $\mu$ F, 20V, Tant	515/E3	6/F3	ITT	Tap/F010F200	C-179-10
C305	10 $\mu$ F, 20V, Tant	515/E3	7/F4	ITT	Tap/F010F200	C-179-10
C306	10 $\mu$ F, 20V, Tant	515/E2	8/F4	ITT	Tap/F010F200	C-179-10
C307	10 $\mu$ F, 20V, Tant	515/E2	9/F4	ITT	Tap/F010F200	C-179-10
C308	620 $\mu$ F, 35V, Electrolytic	515/E3	10/F5	RIC	HC-SC-620 35-8P	C-309-620
C309	620 $\mu$ F, 35V, Electrolytic	515/E2	11/F5	RIC	HC-SC-620 35-8P	C-309-620
C310	6800 $\mu$ F, 25V, Alum Elect	515/E4	12/G4	RIC	HCP-11-6800 25-8P	C-314-6800
C311	10 $\mu$ F, 20V, Tant	515/E4	13/G4	ITT	Tap/F00F200	C-179-10
C312	10 $\mu$ F, 20V, Tant	515/E4	14/G5	ITT	Tap/F010F200	C-179-10
C0-7	3 Wire Line Cord	--	-/A5	PAT	--	C0-7
CR301	Rectifier, Bridge	515/D4	17/C4	--	--	RF-51
CR302	Rectifier	515/D4	18/G4	EDI	PE05	RF-48
CR303	Rectifier	515/D2	19/G5	EDI	PF-40	RF-46
F301	Slow Blow 250V 1A/3AG	515/B3	21/A,B 4	L-F	MDL	FU-10
F301	Slow Blow 250V, 1/2A/3AG	515/B3	22/A,B 4	L-F	MDL	FU-4
J302	Molex	515/C5	--	MOL	09-50-3031	CS-287-3
J303	Molex	515/B2	--	MOL	09-50-3031	CS-287-3
J304	Molex	515/F4,5	23/D3	MOL	09-52-3102	CS-332-12
J305	Molex	515/F2,3	24/G3	MOL	09-52-3102	CS-332-12
J306						CS-249
J307						CS-249
P301	Filter, Power line	515/A3	26/B5	COC	6EF1	LF-2
P302	Molex, Male	515/C5	27/B3	MOL	A-2391-3A	CS-288-3
P303	Molex, Male	515/B2	28/B5	MOL	A-2391-3A	CS-288-3

**Table 7-3. Power Supply PC-515 Parts List (Cont.)**

Circuit Desig.	Description	Schematic Location	PC-Board Item No./Location	Mfr. Code	Mfr. Desig.	Keithley Part No.
R301	220k, 10%, 1W, Comp	515/D5	30/C4	A-B	GB	R-2-220k
R302	1k, 10%, 1/2W, Comp	515/E4	31/D4	A-B	EB	R-1-1k
R303	4.7k, 5%, 1/4W, Comp	515/E3	32/F4	BRN	CR25*	R-76-4.7k
R304	470, 10%, 1/2W, Comp	515/E4	33/F4	A-B	EB	R-1-470
R305	4.7k, 5%, 1/4W, Comp	515/E2	34/F4	BRN	CR25*	R-76-4.7k
S301	Switch DPDT	515/C2	37/B4	COW	--	SW-397
S302	Switch DPDT	515/C3	38/B5	COW	--	SW-397
S303	Switch SPDT	-/B2	39/A3	CaK	JMT-123	SW-236
S304	Switch, Power	-/B1	--	SCH	--	SW-420
T301	Transformer	515/D,2,3,4,5	42/E,0,4,5	K-I	--	TR-175
VR301	Voltage Regulator, Negative	515/E3	45/F4	MOT	MC7915CT	IC-174
VR302	Voltage Regulator, Positive	515/E2	46/F4	MOT	MC7815CT	IC-96
VR303	Voltage Regulator, 5 Volt	515/E3	47/G5	MOT	MLM109KA	IC-98

**Table 7-4. IEEE Interface PC-517 Parts List**

Circuit Desig.	Description	Schematic Location	PC-Board Item No./Location	Mfr. Code	Mfr. Desig.	Keithley Part No.
C701	.1 $\mu$ F, 50V, CerF	517/A1	3/C4	ERI	8121-M050-651-104M	C-237-.1
C702	.1 $\mu$ F, 50V, CerF	517/A1	4/C4	ERI	8121-M050-651-104M	C-237-.1
C703	.1 $\mu$ F, 50V, CerF	517/B1	5/C5	ERI	8121-M050-651-104M	C-237-.1
C704	.1 $\mu$ F, 50V, CerF	517/B1	6/D4	ERI	8121-M050-651-104M	C-237-.1
C705	.1 $\mu$ F, 50V, CerF	517/B1	7/D4	ERI	8121-M050-651-104M	C-237-.1
C706	.1 $\mu$ F, 50V, CerF	517/B1	8/E4	ERI	8121-M050-651-104M	C-237-.1
C707	.1 $\mu$ F, 50V, CerF	517/B1	9/D4	ERI	8121-M050-651-104M	C-237-.1
C708	.1 $\mu$ F, 50V, CerF	517/C1	10/E4	ERI	8121-M050-651-104M	C-237-.1
C709	.1 $\mu$ F, 50V, CerF	517/C1	11/F4	ERI	8121-M050-651-104M	C-237-.1
C710	.1 $\mu$ F, 50V, CerF	517/C1	12/F4	ERI	8121-M050-651-104M	C-237-.1
C711	.1 $\mu$ F, 50V, CerF	517/C1	13/F5	ERI	8121-M050-651-104M	C-237-.1
C712	10 $\mu$ F, 25V, Alum	517/B6	14/G4	ITT	TAP/Γ010, F200	C-314-10
C713	22 $\mu$ F, 25V, Alum	517/B6	15/G5	C-I	TSD3-10-336 PCM1287	C-314-22
J701	Right Angle Mount Rect.	517/G2,3,4,5	19/B4	AMP	552791-1	CS-377
R701	Thick Film	517/D1	20/D5	BRNS	4308R-101-223	TF-100
S701	Dip Switch	517/E1	21/B5	CTS	206-7	SW-377
U701	Bus Transceivers	517/F5	25/C4	MOT	MC3448A	IC-193
U702	Bus Transceivers	517/F2	26/D4	MOT	MC3448A	IC-193
U703	Buffer/Line Driver	517/B5	27/C5	MOT	74LS244	IC-230
U704	Bus Transceivers	517/F4	28/C4	MOT	MC3448A	IC-193
U705	Bus Transceivers	517/F3	29/C4	MOT	MC3448A	IC-193
U706	GPIO	517/E	30/D,E4	MOT	68488	LSI-14

**Table 7-4. IEEE Interface PC-517 Parts List (Cont.)**

Circuit Desig.	Description	Schematic Location	PC-Board Item No./Location	Mfr. Code	Mfr. Desig.	Keithley Part No.
U707	Hex Inverter	517/SEV	31/D4	MOT	74LS04	IC-186
U708	Triple-3 Input Nand	517/SEV	32/E4	MOT	74LS10	IC-155
U709	Hex-3 State Buffer	517/D2	33/F4	MOT	74LS367	IC-161
U710	Quad Bus Receivers	517/B4	34/F4	MOT	8T26	IC-180
U711	Quad Bus Receivers	517/B2	35/F5	MOT	8T26	IC-180
VR701	5 Volt Regulator	517/B6	37/G5	MOT	MC7805	IC-93

**Table 7-5. CPU Board PC-518 Parts List**

Circuit Desig.	Description	Schematic Location	PC-Board Item No./Location	Mfr. Code	Mfr. Desig.	Keithley Part No.
C901	.1 $\mu$ F, 50V, CerF	518/B5	3/B2	ERI	8121-M050-651-104M	C-237-.1
C902	.1 $\mu$ F, 50V, CerF	518/B5	4/C2	ERI	8121-M050-651-104M	C-237-.1
C903	.1 $\mu$ F, 50V, CerF	518/B5	5/C2	ERI	8121-M050-651-104M	C-237-.1
C904	.1 $\mu$ F, 50V, CerF	518/B5	6/E2	ERI	8121-M050-651-104M	C-237-.1
C905	.1 $\mu$ F, 50V, CerF	518/B5	7/F2	ERI	8121-M050-651-104M	C-237-.1
C906	.1 $\mu$ F, 50V, CerF	518/B5	8/F2	ERI	8121-M050-651-104M	C-237-.1
C907	.1 $\mu$ F, 50V, CerF	518/B5	9/B2	ERI	8121-M050-651-104M	C-237-.1
C908	.1 $\mu$ F, 50V, CerF	518/B5	10/B2	ERI	8121-M050-651-104M	C-237-.1
C909	.1 $\mu$ F, 50V, CerF	518/B5	11/B2	ERI	8121-M050-651-104M	C-237-.1
C910	22pF, 1000V, CerD	518/D2	12/D2	ERI	838-000-U230-220K	C-64-22pF
C911	22pF, 1000V, CerD	518/D2	13/D2	ERI	838-000-U250-220K	C-64-22pF
C912	.1 $\mu$ F, 50V, CerF	518/D2	14/F2	ERI	8121-M050-651-104M	C-237-.1
C913	.1 $\mu$ F, 50V, CerF	518/C5	15/A3	ERI	8121-M050-651-104M	C-237-.1
C914	.1 $\mu$ F, 16V, CerD	518/D2	16/B3	CLB	UK16-104	C-238-.1
C915	.01 $\mu$ F, 16V, CerD	518/E2	17/B3	CLB	UK16-103	C-238-.01
C916	.1 $\mu$ F, 16V, CerD	518/E2	18/B3	CLB	UK16-104	C-238-.1
C917	.1 $\mu$ F, 50V, CerF	518/C5	19/D3	CLB	8121-M050-651-104M	C-237-.1
C918	22 $\mu$ F, 25V, Alum	518/A5	20/D3	ITT	TAP/F022, F200	C-314-22
C919	.1 $\mu$ F, 50V, CerF	518/C5	21/E3	CLB	8121-M050-651-104M	C-237-.1
C920	.1 $\mu$ F, 50V, CerF	518/C5	22/E3	CLB	8121-M050-651-104M	C-237-.1
C921	.1 $\mu$ F, 50V, CerF	518/C5	23/E3	CLB	8121-M050-651-104M	C-237-.1

**Table 7-5. CPU Board PC-518 Parts List (Cont.)**

Circuit Desig.	Description	Schematic Location	PC-Board Item No./Location	Mfr. Code	Mfr. Desig.	Keithley Part No.
C922	.1 $\mu$ F, 50V, CerF	518/C5	24/F3	CLB	8121-M050- 651-104M	C-237-.1
C923	10 $\mu$ F, 25V, Alum	518/B5	25/D3	C-I	TS03-10-336 PCM-1287	C-314-10
C924	.1 $\mu$ F, 50V, CerF	518/C5	26/E3	CLB	8121-M050- 651-104M	C-237-.1
CR901	Diode, Silicon	518/E1	32/A3	T-I	1N914	RF-28
R901	Thick Film	518/A,B	40/C2	BRN	4306R-101-332	TF-101
R902	1M, 5%, 1/4W, Comp	518/E1	41/A3	MEP	CR25*	R-76-1M
R903	1M, 5%, 1/4W, Comp	518/E2	42/B3	MEP	CR25*	R-76-1M
U901	Buffer/Line Driver	518/C4	65/A2	MOT	74LS244	IC-230
U902	Dual 4 Input Nand	518/B3,4	66/B2	MOT	SN74LS20	IC-232
U903	Dual 4 Input Nand	518/D5,6	67/C2	MOT	SN74LS20	IC-232
U904	Triple-3 Input Nor	518/D4,6	68/C2	MOT	SN74LS27	IC-233
U905	Microprocessor with clock	518/D1,2,3,4	69/D,E,2	MOT	MC6808	LSI-27
U906	PROM	518/F4	70/E2	INT	2716	PRO-114**
U907*	PROM	518/E4	71/F2	INT	2716	PRO-115**
U908	Buffer/Line Driver	518/C3	72/A2	MOT	74LS244	IC-230
U909	Hex Inverter	518/SEV	73/B2	MOT	74LS04	IC-186
U910	Triple-3 Input Nand	518/D5	74/C2	T-I	74LS14	IC-155
U911	Hex-3 State Buffer	518/C5	75/A2	F-I	74LS367	IC-161
U912	Quad-2 Input Nand	518/SEV	76/B2	MOT	74LS00	IC-163
U913	Programmable Module Timer	518/B2,3	77/C3	MOT	MC6840	LSI-26
U914	Decoder/Multiplexer	518/D4	78/C2	SIG	SN74LS139	IC-190
U915	PROM	518/F3	79/F2	INT	2716	PRO-115*
U916	Quad-2 Input Nand	518/SEV	80/A3	MOT	SN74LS03	IC-231
U917	Timing Circuit	518/E2	81/B3	SIG	NE555	IC-71
U918	Quad Bus Receivers	518/C2	82/C3	SIG	8T26	IC-180
U919	Static RAM	518/E2	83/E3	NEC	2114	LSI-15

\*Manufacturers Designation includes parts description, e.g., CR25, 1M, 5%, 1/4W, Comp, and R903.

\*\*Order same as current software level displayed on power-up. For example, if C1 is displayed, order PRO-114-C1.



**Table 7-5. CPU Board PC-518 Parts List (Cont.)**

Circuit Desig.	Description	Schematic Location	PC-Board Item No./Location	Mfr. Code	Mfr. Desig.	Keithley Part No.
U920	Static RAM	518/E1	84/E3	NEC	2114	LSI-15
U921	Quad Bus Receivers	518/C1	85/C3	SIG	8T26	IC-180
U922	Static RAM	518/F2	86/E3	NEC	2114	LSI-15
U923	Static RAM	518/F1	87/E3	NEC	2114	LSI-15
U924*	PROM	518/E3	88/F3	INT	2716	PRO-115*
VR201	5-Volt Regulator	518/E3	93/D3	MOT	MC7805	IC-93
VR901	5-Volt Regulator	518/B5	94/D3	MOT	MC7805	IC-93
Y901	4MHZ Crystal	518/D2	111/E2	CTS	MP040	CR-10
TP1	Test Point	E5	48/D2	K-I	---	CS-339-4
TP2	Test Point	E5	49/D2	K-I	---	CS-339-4
TP3	Test Point	E5	50/D2	K-I	---	CS-339-4
TP4	Test Point	F5	51/D2	K-I	---	CS-339-4
TP5	Test Point	E5	52/B3	K-I	---	24249A
TP6	Test Point	C6	53/C2	K-I	---	CS-339-2
TP7	Test Point	C6	54/C3	K-I	---	CS-339-2
TP8	Test Point	B5	55/D2	K-I	---	CS-339-2
TP9	Test Point	B5	56/D2	K-I	---	CS-339-2
TP10	Test Point	A2	57/C3	K-I	---	CS-339-3
TP11	Test Point	B1	58/C3	K-I	---	CS-339-3
TP12	Test Point	B2	59/C3	K-I	---	CS-339-3
W901	Jumper	G4	97/D2	---	---	J-3
W902	Jumper	D5	98/B2	---	---	J-3
W903	Jumper	D6	99/B2	---	---	J-3
W904	Jumper	D5	100/C2	---	---	J-3
W905	Jumper	D5	101/C2	---	---	J-3
W906	Jumper	E5	102/B2	---	---	J-3
W907	Jumper	D6	103/B2	---	---	J-3
W908	Jumper	B5	104/B3	---	---	J-3
W909	Jumper	G4	105/F3	---	---	J-3

\*Populated in PC-518 when U906 and U915 are 2716's.

**Table 7-6. Isolator Board PC-519 Parts List**

Circuit Desig.	Description	Schematic Location	PC-Board Item No./Location	Mfr. Code	Mfr. Desig.	Keithley Part No.
C801	.1 $\mu$ F, 50V, CerF	519/B1	3/B2	ERI	8121-M050-651-104M	C-237-.1
C802	.1 $\mu$ F, 50V, CerF	519/B1	4/B2	ERI	8121-M050-651-104M	C-237-.1
C803	.1 $\mu$ F, 50V, CerF	519/B1	5/B2	ERI	8121-M050-651-104M	C-237-.1
C804	.1 $\mu$ F, 50V, CerF	519/B1	6/B2	ERI	8121-M050-651-104M	C-237-.1
C805	.1 $\mu$ F, 50V, CerF	519/B1	7/B2	ERI	8121-M050-651-104M	C-237-.1
C806	.1 $\mu$ F, 50V, CerF	519/B1	8/B2	ERI	8121-M050-651-104M	C-237-.1
C807	10 $\mu$ F, 25V, Alum	519/B1	9/C2	C-I	TSD3-10-336, PCM1287	C-314-10
C808	22 $\mu$ F, 25V, Alum	519/A1	10/C3	ITT	TAD/F010, F200	C-314-22
C809	.1 $\mu$ F, 50V, CerF	519/G5	11/E2	ERI	8121-M050-651-104M	C-237-.1
C810	.1 $\mu$ F, 50V, CerF	519/G5	12/E2	ERI	8121-M050-651-104M	C-237-.1
C811	.1 $\mu$ F, 50V, CerF	519/G5	13/E2	ERI	8121-M050-651-104M	C-237-.1
C812	.1 $\mu$ F, 50V, CerF	519/G5	14/E2	ERI	8121-M050-651-104M	C-237-.1
C813	.1 $\mu$ F, 16V, CerD	519/E5	15/E2	CLB	UK16-104	C-238-.1
C814	.1 $\mu$ F, 16V, CerD	519/E4	16/F2	CLB	UK16-104	C-238-.1
C815	.1 $\mu$ F, 16V, CerD	519/E3	17/F2	CLB	UK16-104	C-238-.1
C816	22 $\mu$ F, 25V, Alum	519/G5	18/F2	C-I	TSD3-10-336, PCM1287	C-314-22
C817	.1 $\mu$ F, 50V, CerF	519/G5	19/F2	ERI	8121-M050-651-104M	C-237-.1
C818	.1 $\mu$ F, 16V, CerD	519/E2	20/F2	CLB	UK16-104	C-238-.1
C819	.1 $\mu$ F, 50V, CerF	519/B1	21/C3	ERI	8121-M050-651-104M	C-237-.1
CR801	Rectifier	519/A6	79/D2	T-I	1N914	RF-28
CR802	Rectifier	519/A6	80/D2	T-I	1N914	RF-28
CR803	Rectifier	519/A6	81/D2	T-I	1N914	RF-28
CR804	Rectifier	519/A6	82/D2	T-I	1N914	RF-28
P801	Connector	519/A	23/G2	3M	3429-2002	CS-322-26Z
R801	Thick Film	519/D4	25/B1	BRN	430, 8R101-223	TF-100
R802	270, 5%, 1/4W, Comp	519/E3	26/F2	BRN	CR25*	R-76-270

**Table 7-6. Isolator Board PC-519 Parts List (Cont.)**

Circuit Desig.	Description	Schematic Location	PC-Board Item No./Location	Mfr. Code	Mfr. Desig.	Keithley Part No.
R803	270, 5%, 1/4W, Comp	519/E2	27/F2	BRN	CR25*	R-76-270
R804	270, 5%, 1/4W, Comp	519/E4	28/F2	BRN	CR25*	R-76-270
R805	390, 5%, 1/4W, Comp	519/D1	29/F2	BRN	CR25*	R-76-390
R806	390, 5%, 1/4W, Comp	519/E4	30/F2	BRN	CR25*	R-76-390
R807	390, 5%, 1/4W, Comp	519/E3	31/F2	BRN	CR25*	R-76-390
R808	10k, 5%, 1/4W, Comp	519/F1	32/F2	BRN	CR25*	R-76-10k
R809	390, 5%, 1/4W, Comp	519/E2	33/F2	BRN	CR25*	R-76-390
R810	270, 5%, 1/4W, Comp	519/E1	34/F2	BRN	CR25*	R-76-270
S801	Switch	519/D3	39/B1	GRH	76SB04	SW-422
U801	Hex Inverter	519/SEV	43/A2	MOT	74LS04	IC-186
U802	Decoder/Multiplexer	519/A5	44/A2	SIG	SN74LS139	IC-190
U803	Buffer/Line Driver	519/A4	45/A2	MOT	74LS244	IC-230
U804	Triple-3 Input Nand	519/SFV	46/B2	T-I	74LS10	IC-155
U805	Quad Bus Receivers	519/A2	47/B2	SIG	8T26	IC-180
U806	Quad Bus Receivers	519/A3	48/B2	SIG	8T26	IC-180
U807	Versatile Interface Adapter	519/D	49/C2	SYN	SYP6522	LSI-28
U808	Shift Register	519/D2	50/C2	T-I	SN74LS164	IC-127
U809	Quad-2 Input Nand	519/SEV	51/C2	T-I	SN7400N	IC-38
U810	Quad-2 Input Nor	519/SEV	52/D2	SIG	74LS02	IC-179
U811	Odd/Even Parity Generator Checker	519/F3	53/D2	T-I	74LS280	IC-236
U812	Shift Register	519/F3	54/D2	T-I	SN74LS164	IC-127
U813	Quad-2 Input Nand	519/SEV	55/E2	T-I	SN7400N	IC-38
U814	Odd/Even Parity Generator Checker	519/F4	56/E2	T-I	74LS280	IC-236
U815	Shift Register	519/F2	57/E2	T-I	SN74LS164	IC-127
U816	8-Bit Parallel Serial Conv.	519/F1	58/F2	MOT	74LS165	IC-237

\*Manufacturers Designation includes parts description, e.g. CR25, 390, 1%, 1/4W, Comp for R810.

**Table 7-6. Isolator Board PC-519 Parts List (Cont.)**

Circuit Desig.	Description	Schematic Location	PC-Board Item No./Location	Mfr. Code	Mfr. Desig.	Keithley Part No.
AT1	Opto Coupler	519/E5	68/F2	H-P	HCPL-2601	IC-239
AT2	Opto Coupler	519/E4	69/F2	H-P	CCPL-2601	IC-239
AT3	Opto Coupler	519/E3	70/F2	H-P	HCPL-2601	IC-239
AT4	Opto Coupler	519/E1	71/G2	H-P	HCPL-2601	IC-239
VR801	5 Volt Regulator	519/D2	75/D2	F-I	SH323SC	IC-240

**Table 7-7. A/D Converter PC-520 Parts List**

Circuit Desig.	Description	Schematic Location	PC-Board Item No./Location	Mfr. Code	Mfr. Desig.	Keithley Part No.
C501	.1 $\mu$ F, 16V, CerD	520/H5	3/B2	CLB	UK16-104	C-238-.1
C502	3600pF, 1000V, CerD	520/A3	4/C2	CLB	5% MAL 3600pF	C-138-3600pF
C503	.1 $\mu$ F, 16V, CerD	520/H5	5/E1	CLB	UK16-104	C-238-.1
C504	.1 $\mu$ F, 16V, CerD	520/H5	6/E2	CLB	UK16-104	C-238-.1
C505	.1 $\mu$ F, 16V, CerD	520/H5	7/F2	CLB	UK16-104	C-238-.1
C506	.1 $\mu$ F, 16V, CerD	520/F1	8/C3	CLB	UK16-104	C-238-.1
C507	100pF, 1000V, CerD	520/G1	9/C3	CRL	DD-101	C-64-100pF
C508	.1 $\mu$ F, 16V, CerD	520/G1	10/C3	CLB	UK16-104	C-238-.1
C509	100pF, 1000V, CerD	520/F2	11/C3	CRL	DD-101	C-64-100pF
C510	.1 $\mu$ F, 16V, CerD	520/E1	12/D3	CLB	UK16-104	C-238-.1
C511	.1 $\mu$ F, 16V, CerD	520/H5	13/D3	CLB	UK16-104	C-238-.1
C512	.1 $\mu$ F, 50V, CerF	520/H5	14/E2	ERI	8121M050651104M	C-237-.1
C513	.1 $\mu$ F, 50V, CerF	520/H5	15/E2	ERI	8121M050651104M	C-237-.1
C514	.1 $\mu$ F, 16V, CerD	520/H5	16/E3	CLB	UK16-104	C-238-.1
L501	Choke	520/F1	19/C3	NYT	SWD-100	CH-14
Q501	N-Channel J-FET	520/B6	21/B1	INT	ITE4392	TG-77
Q502	Transistor Array	520/4A	22/C2	K-I	29198A	29198A
Q503	NPN Transistor	520/A3	23/C2	MOT	2N3904	TG-47
Q504	PNP Transistor	520/A2	24/C2	F-I	2N3638A	TG-84
Q505	PNP Transistor	520/B1	25/B2	F-I	2N3638A	TG-84
Q506	PNP Transistor	520/C1	26/B2	F-I	2N3638A	TG-84
Q507	Transistor Array	520/C1	27/C2	K-I	29198A	29198A
Q508	N-Channel J-FET	520/G1	28/C3	INT	ITE4392	TG-77
Q509	NPN Transistor	520/B6	29/E3	MOT	2N3904	TG-47
Q510	PNP Transistor	520/B2	30/B1	F-I	2N3638A	TG-84
R501	Thick Film	520/Several	33/B2	DLE	TF-86	TF-86
R502	Thick Film	520/Several	34/C2	DLE	TF-85	TF-85
R503	6.8M, 10%, 1/4W, Comp	520/B5	35/B3	DLE	CR25*	R-76-6.8M

**Table 7-7. A/D Converter PC-520 Parts List (Cont.)**

Circuit Desig.	Description	Schematic Location	PC-Board Item No./Location	Mfr. Code	Mfr. Desig.	Keithley Part No.
R504	4.99k, 1%, 1/8W, Fixed	520/B6	36/B3	DLE	MFF1/8	R-88-4.99k
R505	330 $\Omega$ , 5%, 1/4W, Comp	520/F2	37/B3	BRN	CR25*	R-76-330
R506	330 $\Omega$ , 5%, 1/4W, Comp	520/F1	38/B3	BRN	CR25*	R-76-330
R507	22 $\Omega$ , 5%, 1/4W, Comp	520/G1	39/C3	BRN	CR25*	R-76-22
R508	10M, 10%, 1/4W, Comp	520/F2	40/C3	BRN	CR25*	R-76-10M
R509	6.8, 5%, 1/4W, Comp	520/E1	41/C3	BRN	CR25*	R-76-6.8
R510	10K, 5%, 1/4W, Comp	520/C6	42/E2	BRN	CR25*	R-76-6.8
U501	Bi-Fet OP AMP	520/A6	47/B1	NAT	LF351N	IC-176
U502	Triple-3 Input Nand	520/D3	48/D1	MOT	74LS10	IC-155
U503	Flip-Flop	520/E3	49/D1	T-I	74LS74	IC-144
U504	Triple-3 Input Nand	520/B5	50/E1	MOT	74LS10	IC-155
U505	Decade & Binary Counter	520/F4	51/F1	T-I	74LS393	IC-213
U506	Flip Flop	520/B3	52/B2	T-I	SN74574N	IC-216
U507	Bi Fet OP AMP	520/A3	53/C2	NAT	LF351N	IC-176
U508	Quad 2-Input Nand	520/Several	54/D2	MOT	74LS00	IC-163
U509	UP/DOWN Counter	520/F5	55/E2	T-I	SN74LS193	IC-214
U510	UP/DOWN Counter	520/G5	56/E2	T-I	SN74LS193	IC-214
U511	Decade & Binary Counter	520/D4	57/E2	T-I	SN74LS393	IC-213
U512	Buffer/Line Driver	520/E6	58/F2	MOT	74LS244	IC-230
U513	Quad 2-Input NOR	520/Several	59/B2	SIG	74LS02	IC-179
U514	Bi Fet OP AMP	520/B1	60/B2	NAT	LF351N	IC-176
U515	Voltage Comparator	520/C2	61/C2	NAT	LM311N	IC-173
U516	UP/DOWN Counter	520/F1	62/D3	SIG	N74193B	IC-44
U517	Flip Flop	520/E6	63/E3	MOT	74LS374	IC-242
U518	Decade & Binary Counter	520/D4	64/F3	T-I	74LS393	IC-213
U519	Buffer/Line Driver	520/D5	65/F3	MOT	74LS244	IC-230
VR501	Zener Diode	520/A6	69/A2	SIF	1N4571	DZ-60
Y501	Crystal	520/F1	72/C3	BOM	BM-22	CR-12

\*Manufacturers Designation includes Parts Description - e.g. CR25, 22, 5%, 1/4W, Comp, R507.

**Table 7-8. Electrometer Module PC-523 and PC-522 Parts List**

Circuit Desig.	Description	Schematic Location	PC-Board Item No./Location	Mfr. Code	Mfr. Desig.	Keithley Part No.
C601	10 $\mu$ F, 350V, Alum Elect	522/C2	3/E2	NIC	350-E-NA-10-T	C-312-10
C602	10 $\mu$ F, 350V, Alum Elect	522/C3	4/E2	NIC	350-E-NA-10-T	C-312-10
C603	4.7 $\mu$ F, 350V, Alum Elect	522/B2	5/E2	UCC	350VB-4R7	C-240-4.7
C604	4.7 $\mu$ F, 350V, Alum Elect	522/B3	6/E2	UCC	350VB-4R7	C-240-4.7
C605	.1 $\mu$ F, 250V, Met Poly	522/D3	7/D2	MEP	C280AE/P100K	C-178-0.1
C606	470 $\mu$ F, 16V, Alum Elect	522/C4	8/E2	NIC	HC-4C-470-16-8P	C-313-470
C607	470 $\mu$ F, 16V, Alum Elect	522/C3	9/E2	NIC	HC-4C-470-16-8P	C-313-470
C608	250 $\mu$ F, 25V, Alum Elect	522/C4	10/E3	RIC	HC-4B-250-25-8P	C-314-250
C609	250 $\mu$ F, 25V, Alum Elect	522/C4	11/E3	RIC	HC-4B-250-25-8P	C-314-250
C610	.01 $\mu$ F, 500V, CerD	522/C4	12/E3	SPG	5GA S-S10 .01mf 20%, 500V	C-22-.01
C651	150pF, 500V, Polysty	523/B4	3/B3	MAL	150PFSX	C-138-150p
C653	.047 $\mu$ F, 250V, Met, Poly	523/B2	5/D2	MEP	106,.047,FD, 250V, 20%	C-178-.047
C654	10 $\mu$ F, 20V, Tant	523/D2	6/D2	ITT	TAP/F, 35V, 20%	C-179-10
C655	47pF, 500V, Polysty	523/B3	7/C2	MAL	47mmf SX	C-138-47p
C656	5000pF, 500V, Polysty	523/B3	8/C2	MAL	5000PF SX	C-138-5000p
C657	47pF, 500V, Polysty	523/B3	9/B3	MAL	47mmf SX	C-138-47p
C658	10pF, 500V, Polysty	523/C5	10/B3	MAL	20mmf SX	C-138-10p
C659	10 $\mu$ F, 20V, Tant	523/D3	11/C3	ITT	TAP/F, 35V, 20%	C-179-10
C660	10 $\mu$ F, 20V, Tant	523/D3	12/C3	ITT	TAP/F, 35V, 20%	C-179-10
C661	.01 $\mu$ F, 500V, CerD	523/C4	13/C3	SPG	5 GAS-S10, .01mf 20%, 500V	C-22-.01
C662	.01 $\mu$ F, 500V, CerD	523/C3	14/D3	SPG	5 GAS-S10, .01mf 28%, 500V	C-22-.01
C663	10 $\mu$ F, 20V, Tant	523/H3	15/F3	ITT	TAP/F, 35V, 20%	C-179-10
C664	10 $\mu$ F, 20V, Tant	523/F5	16/G2	ITT	TAP/F, 35V, 20%	C-179-10

**Table 7-8. Electrometer Module PC-523 and PC-522 Parts List (Cont.)**

Circuit Desig.	Description	Schematic Location	PC-Board Item No./Location	Mfr. Code	Mfr. Desig.	Keithley Part No.
C665	1 $\mu$ F, 50V, CerF	523/C4	17/C3	EMC	50 30 E S50 RD105M	C-237-1.0
C666	.001 $\mu$ F	523/G5	F3/C3	ERI	808-000-Z5RU 102K	C-22-.001
C667	.001 $\mu$ F	523/G5	F3/C3	ERI		C-22-.001
C668	.001 $\mu$ F	523/G5	F3/C3	ERI		C-22-.001
CR601	Diode, Silicon	522/D3	18/A2	T-I	1N914	RF-28
CR602	Rectifier	522/C2	19/B2	ITT	S18	RF-38
CR603	Diode, Silicon	522/F2	20/B2	T-I	1N914	RF-28
CR604	Rectifier	522/G3	21/B2	ITT	S18	RF-38
CR605	Rectifier	522/D3	22/D2	ITT	S18	RF-38
CR606	Rectifier	522/D3	23/D2	ITT	S18	RF-38
CR607	Rectifier	522/F3	24/D2	ITT	S18	RF-38
CR608	Rectifier	522/F3	25/D2	ITT	S18	RF-38
CR609	Rectifier	522/C2	26/E1	ITT	S18	RF-38
CR610	Rectifier	522/C3	27/E2	ITT	S18	RF-38
CR611	Rectifier	522/C3	28/E2	ITT	S18	RF-38
CR612	Rectifier	522/C3	29/E2	ITT	S18	RF-38
CR613	Rectifier	522/D2	30/A2	ITT	S18	RF-38
CR614	Rectifier	522/F2	31/B2	ITT	S18	RF-38
CR615	Diode, Silicon	522/D2	32/B3	T-I	1N914	RF-28
CR616	Diode, Silicon	522/E2	33/B3	T-I	1N914	RF-28
CR617	Diode, Silicon	522/E2	34/B3	T-I	1N914	RF-28
CR618	Diode, Silicon	522/E2	35/B3	T-I	1N914	RF-28
CR619	Diode, Silicon	522/F2	36/B3	T-I	1N914	RF-28
CR620	Diode, Silicon	522/E2	37/B3	T-I	1N914	RF-28
CR621	Diode, Silicon	522/G2	38/C3	T-I	1N914	RF-28
CR622	Diode, Silicon	522/G3	39/C3	T-I	1N914	RF-28
CR623	Diode, Silicon	522/G2	40/C3	T-I	1914	RF-28
CR624	Rectifier	522/C4	41/E2	EDI	PF40	RF-46
CR625	Rectifier	522/C4	42/E3	EDI	PF-40	RF-46
CR652	Diode, Silicon	523/F4	24/D2	T-I	1N914	RF-28



**Table 7-8. Electrometer Module PC-523 and PC-522 Parts List (Cont.)**

Circuit Desig.	Description	Schematic Location	PC-Board Item No./Location	Mfr. Code	Mfr. Desig.	Keithley Part No.
CR653	Diode, Silicon	523/F5	25/D2	T-I	1N914	RF-28
CR654	Diode, Silicon	523/E5	26/D2	T-I	1N914	RF-28
CR655	Diode, Silicon	523/F4	27/D3	T-I	1N914	RF-28
CR656	Diode, Silicon	523/F4	28/E3	T-I	1N914	RF-28
CR657	Diode, Silicon	523/F1	29/D3	T-I	1N914	RF-28
CR658	Diode, Silicon	523/F2	30/F3	T-I	1N914	RF-28
CR659	Diode, Silicon	523/F2	31/D3	T-I	1N914	RF-28
CR660	Diode, Silicon	523/F2	32/E3	T-I	1N914	RF-28
CR661	Diode, Silicon	523/F3	33/E2	T-I	1N914	RF-28
CR662	Diode, Silicon	523/F3	34/F2	T-I	1N914	RF-28
CR663	Diode, Silicon	523/E3	35/F2	T-I	1N914	RF-28
CR664	Diode, Silicon	523/F5	36/F2	T-I	1N914	RF-28
F601	Fuse, 2 Amp	-/B5	--	L-F	312002	FU-13
J601	Binding Post, Red	-/B5	--	SUP	1517	BP-11-2
J602	Binding Post, Black	-/B5	--	SUP	DF-21-BC	BP-11-0
J651	Jack, Triax	-/A5	--	POM	3580	CS-253
J652	Connector, Microphone	-/A1	--	AMP	80PC2F	CS-32
K601	Relay	522/G3	49/C3	COT	UT45027	RL-66
K602	Relay	522/G3	50/C3	COT	UT45027	RL-66
K603	Relay	522/G2	51/C3	COT	UF40118	RL-65
K651	Relay	523/B2, F1	43/B2	COT	UF40117	RL-64
K652	Relay	523/B3, F1	44/B2	COT	UF40117	RL-64
K653	Relay	523/B3, F2	45/B2	COT	UF40117	RL-64
K654	Relay	523/B3, F2	46/B2	COT	UF40117	RL-64
K655	Relay	523/B2, F4	47/B3	COT	UF40117	RL-64
K656	Relay	523/B5, F4	48/B3	COT	UF40117	RL-64
K657	Relay	523/B2, F4	49/D2	COT	UF40118	RL-65
K658	Relay	523/C3, E5	50/D2	COT	UF40118	RL-65
K659	Relay	523/C2, F4	51/D2	COT	UF40118	RL-65
K660	Relay	523/D4, F2	52/E2	COT	UF40118	RL-65

**Table 7-8. Electrometer Module PC-523 and PC-522 Parts List (Cont.)**

Circuit Desig.	Description	Schematic Location	PC-Board Item No./Location	Mfr. Code	Mfr. Desig.	Keithley Part No.
K661	Relay	523/D5, F3	53/F2	COT	UF40118	RL-65
K662	Relay	523/D5, E3	54/F2	COT	UF40118	RL-65
Q601	Transistor, NPN, T0-5	522/D3	57/B2	RCA	2N3439	TG-93
Q602	Transistor, PNP, T0-5	522/F3	58/B2	RCA	2N5416	TG-105
Q603	Transistor, NPN, T0-5	522/D3	59/B2	RCA	2N3439	TG-93
Q604	Transistor, PNP, T0-5	522/F3	60/B2	RCA	2N5416	TG-105
Q605	Transistor, NPN, T0-92	522/E3	61/B3	F-I	2N3904	TG-47
Q606	Transistor, PNP, T0-92	522/E3	62/B3	MOT	2N3906	TG-84
Q607	Transistor, NPN, T0-92	522/H2	63/D3	F-I	2N3904	TG-47
Q608	Transistor, NPN, T0-92	522/H3	64/D3	F-I	2N3904	TG-47
Q651	Transistor, NPN, T0-92	523/G5	58/E2	F-I	2N3904	TG-47
R601	330k, 10%, 1/2W, Comp	522/C2	70/A2	A-B	EB	R-1-330k
R602	330k, 10%, 1/2W, Comp	522/G2	71/B2	A-B	EB	R-1-330k
R603	10k, 5%, 10W, MtF	522/E3	72/C2	SPG	456E1035	R-133-10k
R604	10k, 5%, 10W, MtF	522/E3	73/C2	SPG	456E1035	R-133-10k
R605	.1, .1%, 7.5W, WW	522/E5	74/C2	TEL	PER SPEC	R-262-0.1
R606	330k, 10%, 1/2W, Comp	522/D2	75/A2	A-B	EB	R-1-330k
R607	10k, 5%, 1/4W, Comp	522/D2	76/A2	MEP	CR25, 5%, 10k	R-76-10k
R608	330k, 10%, 1/2W, Comp	522/F2	77/B2	A-B	EB	R-1-330k
R609	10k, 5%, 1/4W, Comp	522/F2	78/B2	MEP	CR25, 5%, 10k	R-76-10k
R610	470, 5%, 1/4W, Comp	522/H3	79/D3	MEP	CR25	R-76-470
R611	680, 5%, 1/4W, Comp	522/H2	80/D3	MEP	CR25, 5%, 680	R-76-680
R612	47, 5%, 1/4W, Comp	522/E3	81/B3	MEP	47, 5%, 1/4W	R-76-47
R613	23.7, 1%, 1/8W, MtF	522/E3	82/B3	DLE	MFF, 1/8T-1, 1%	R-88-23.7
R614	2.4k, 1%, 1/8W, MtF	522/E3	83/B3	DLE	MFF, 1/8	R-88-2.74k
R615	23.7, 1%, 1/8W, MtF	522/E3	84/B3	DLE	MFF, 1/8T-I, 1%	R-88-23.7
R616	47, 5%, 1/4W, Comp	522/E3	85/B3	MEP	47, 5%, 1/4W	R-76-47
R617	2k, 1%, 1/8W, MtF	522/F3	86/B3	DLE	MFF, 1/8T-I, 1%	R-88-2k
R618	47.5%, 1/4W, Comp	522/E3	87/B3	MEP	47, 5%, 1/4W	R-76-47
R619	47.5%, 1/4W, Comp	522/E3	87/B3	MEP	47, 5%, 1/4W	R-76-47

**Table 7-8. Electrometer Module PC-523 and PC-522 Parts List (Cont.)**

Circuit Desig.	Description	Schematic Location	PC-Board Item No./Location	Mfr. Code	Mfr. Desig.	Keithley Part No.
R651	10, 10%, 1/2W	523/B2	63/C2	BRN	3386H-1-100	RP-111-10
R652	200, 10%, 1/2W	523/B2	64/C2	BRN	3386H-1-201	RP-111-200
R653	5k, 10%, 1/2W	523/B3	65/C2	BRN	3386H-1-502	RP-111-5k
R654	2M, 10%, 1/2W	523/B3	66/C2	BRN	33886H-1-205	RP-111-2M
R655	5k, 10%, 1/2W	523/B4	67/C2	BRN	3386H-1-502	RP-111-5k
R656	5k, 10%, 1/2W	523/C5	68/D2	BRN	3386H-1-103	RP-111-10k
R657	50, 10%, 1/2W	523/C2	69/C2	BRN	3386H-1-500	RP-111-50
R658	97.6, .1%, 1/2W, MtF	523/B2	70/C2	DLE	CMF 1/4	R-169-97.6
R659	10k, .1%, 10W, WW	523/B2	71/C2	TFL	24117	R-221-10k
R660	998k, .1%, 1/4W, MtF	523/B3	72/C2	ACI	--	R-264-998k
R661	4.7k, 5%, 1/4W, Comp	523/B3	73/C2	MEP	CR25*	R-76-4.7k
R662	99M, .5%, 1/4W, Met OX	523/B3	74/C2	VIC	--	R-269-99M
R663	9.8G, 2%, 1.5W, Epoxy Coated	523/B4	75/C2	K/M	--	R-289-9.8G
R664	10k, 1%, 1/8W, MtF	523/B4	76/B3	DLE	MFF, 1%, 1/W	R-88-10k
R665	499k, 1%, 1/8W, MtF	523/B5	77/B3	DLE	MFF, 1/10	R-88-499k
R666	90.9k, 1%, 1/8W, MtF	523/C4	78/C3	DLE	CMF, 1/10	R-88-90.9k
R667	10k, 5%, 1/4W, Comp	523/C4	79/C4	MEP	CR25*	R-76-10k
R668	1M, 1%, 1/8W, MtF	523/B5	80/B3	DLE	MFF, 1/8	R-88-1M
R669	10k, 5%, 1/4W, Comp	523/C4	81/C3	MEP	CR25*	R-76-10k
R670	402, .1%, 1/10W, MtF	523/C2	82/D2	TRW	--	R-263-402
R671	6.49k, 1%, 1/8W, MtF	523/D2	83/D3	DLE	CMF, 1/10	R-88-6.49k
R672	Selected 1%, 1/8W, MtF	523/C2	84/D3	DLE	CMF	R-88-*
R673	2.15k, 1%, 1/10W, MtF	523/C2	85/D3	ACI	Metal Film, 1/10	R-263-2.15k
R674	806, 1%, 1/8W, MtF	523/D2	86/D3	DLE	CMF, 1/10	R-88-806
R675	10k, 1%, 1/8W, MtF	523/C3	87/D3	DLE	CMF, 1/8	R-88-10k
R676	10k, 1%, 1/8W, MtF	523/C3	88/D3	DLE	CMF, 1/8	R-88-10k
R677	3.65, 1%, 1/8W, MtF	523/D2	89/D3	DLE	CMF, 1/8	R-88-3.65
R678	1k, 5%, 1/4W, Comp	523/A1	90/E2	MEP	CR25*	R-76-1k

**Table 7-8. Electrometer Module PC-523 and PC-522 Parts List (Cont.)**

Circuit Desig.	Description	Schematic Location	PC-Board Item No./Location	Mfr. Code	Mfr. Desig.	Keithley Part No.
R679	5k, 10%, 1/2W	523/D4	91/E2	BRN	3386H-1-502	RP-111-5k
R680	500, 10%, 1/2W	523/E5	92/F2	BRN	3386H-1-501	RP-111-500
R681	10k, .1%, 1/2W, Comp	523/E5	93/F2	PRP	--	R-287-10k
R682	898k, .1%, 1 1/4W, Comp	523/E4	94/E2	PRP	--	R-286-898k
R683	89.8k, .1%, 1 1/4W, Comp	523/E4	95/F2	PRP	--	R-286-89.8k
R684	4.7k, 5%, 1/4W, Comp	523/F5	96/F2	MEP	CR25*	R-76-4.7k
R685	22k, 5%, 1/4W, Comp	523/F5	97/F2	MEP	CR25*	R-76-22k
R686	4.7k, 5%, 1/4W, Comp	523/E5	98/G2	MEP	CR25, 5%, 4.7k	R-76-4.7k
R687	1k, 5%, 1/4W, Comp	523/C4	99/C3	MEP	CR25, 5%, 1k	R-76-1k
R688	100, 5%, 1/4W, Comp	523/C4	100/C3	MEP	CR25, 5%, 1k	R-76-100
T601	Transformer	522/B2,3,4	94/F,G,2,3	K-1	--	TR-176
U651	OP AMP, T0-99	523/C4	109/C3	A-D	AD515K	IC-241
U652	741, OP AMP, 8 Pin Dip	523/D2	110/D2	SIG	N5741V	IC-42
U653	741, OP AMP, T0-99	523/C3	111/D3	INT	741	IC-77
U654	8 Flip Flops 20 Pin Dip	523/G4	112/E2	MOT	74LS374	IC-242
U655	8 Flip Flops, 20 Pin Dip	523/G2	113/F3	MOT	74LS374	IC-242
U656	3 Nand Gates, 14 Pin Dip	523/G5	114/F3	T-1	74LS10N	IC-155
U657	4 Nand Gates, 14 Pin Dip	523/E5	115/F2	MOT	74LS00	IC-163
U658	4 OR Gates, 14 Pin Dip	523/F3	116/F3	SIG	N7432A	IC-115
VR651	Regulator, T0-220	523/D3	122/C3	F-1	uA7908UC	IC-243
VR652	Zener Diode	523/D2	123/D3	MOT	1N4577	DZ-58
VR653	Zener Diode	523/C2	124/D3	MOT	1N749A	DZ-63

\*Manufacturers Designation includes Parts Description, e.g. CR25, 1K, 5%, 1/4W, Comp, R687.

**Table 7-9. Filter Mux Board PC-521 Parts List**

Circuit Desig.	Description	Schematic Location	PC-Board Item No./Location	Mfr. Code	Mfr. Desig.	Keithley Part No.
C401	.1 $\mu$ F, 50V, CerF	521/D2	4/B2	ERI	8121-M050 651-104M	C-237-.1
C402	.1 $\mu$ F, 16V, CerD	521/G3	5/B3	CLB	UK16-104	C-238-.1
C403	.1 $\mu$ F, 16V, CerD	521/G4	6/B3	CLB	UK16-104	C-238-.1
C404	.1 $\mu$ F, 16V, CerD	521/E5	7/C4	CLB	UK16-104	C-238-.1
C406	.1 $\mu$ F, 16V, CerD	521/D5	9/E3	CLB	UK16-104	C-238-.1
C407	.1 $\mu$ F, 16V, CerD	521/C5	10/E3	CLB	UK16-104	C-238-.1
C408	.47 $\mu$ F 400V, Polypro	521/B1	11/F2	ECl	410B1B4 474K	C-323-.47
C409	.47 $\mu$ F, 400V, Polypro	521/B3	12/F3	ECl	410B1B4 474K	C-323-.47
C410	1000pF, 500V, Polysty	521/B3	13/F3	CLB	C30V, 5%, 1000mF	C-138-1000pF
C411	1000pF, 500V, Polysty	521/B1	14/G3	CLB	C30V, 5% 1000mmF	C-138-1000pF
C412	.1 $\mu$ F, 16V, CerD	521/G5	15/F3	ERI	8121-M050 651-104m	C-237-.1
C413	.1 $\mu$ F, 16V, CerD	521/G5	16/F4	ERI	8121-M050 651-104M	C-237-.1
K401	Relay	521/B2	20/E2	COT	--	RL-60
K402	Relay	521/B3,4	21/E3	COT	--	RL-60
K403	Relay	521/B2	22/F2	COT	--	RL-57
K404	Relay	521/B3,4	23/F3	COT	--	RL-57
K405	Relay	521/C2	24/F3	COT	--	RL-59
R401	100, 5%, 1/4W, Comp	521/C2	28/B2	BRN	CR25*	R-76-100
R402	2.7k, 1%, 1/8W, Film	521/D3	29/B3	DLE	CMF 1/10 1%-T-1	R-88-2.74k
R403	2.7k, 1%, 1/8W, Film	521/C3	30/B3	DLE	CMF 1/10 1%-T-1	R-88-6.04k
R404	10, 5%, 1/4W, Comp	521/G3	31/B3	BRN	CR25*	R-76-10
R405	10, 5%, 1/4W, Comp	521/G4	32/B3	BRN	CR25*	R-76-10
R406	4.7k, 5%, 1/4W, Comp	521/G2	33/B3	BRN	CR25*	R-76-4.7k

**Table 7-9. Filter Mux Board PC-521 Parts List (Cont.)**

Circuit Desig.	Description	Schematic Location	PC-Board Item No./Location	Mfr. Code	Mfr. Desig.	Keithley Part No.
R407	4.7k, 5%, 1/4w, Comp	521/G4	32/B3	BRN	CR25*	R-76-4.7k
R408	13.7k, 1%, 1/8W, Film	521/C3	35/C2	DLE	MF 1/8 1%, T-1	R-88-13.7k
R409	** , .1%, 1/10W, Mtf.	521/D3	36/C2	--	--	29996
R410		521/D3	37/C3	--	--	29996
R411	Cermet Pot	521/D4	38/C2	BRN	3006P	RP-89-100k
R412	150k, 1%, 1/8W, Film	521/D4	39/C2	DLE	CMF 1/10, 1%, T-1	R-88-150k
R413	634k, 1%, 1/8W, Mtf.	521/E3	40/C2	DLE	CMF 1/10	R-88-634k
R414	Thick Film	521/D3,4	41/C2	CAD	--	TF-84
R415	Cermet Pot	521/D3	42/C2	BRN	3006P	RP-89-100
R416	OPTIONAL	521/D2	43/--	--	--	--
R417	643k, 1%, 1/8W, Mtf.	521/E3	44/D2	DLE	CMF, 634K, 1/10	R-88-634k
R418	1K, 1%, 1/8W, Mtf.	521/F3	45/C3	DLE	CMF, 1/10, 1K	R-88-1k
R419	9.09k, 1%, 1/8W, Mtf.	521/F2	46/C3	DLE	CMF, 1/10, 9.09K	R-88-9.09k
R420	10k, 1%, 1/8W, Mtf.	521/G2	47/C3	DLE	CMF, 1/10, 10K	R-88-10k
R422	634k, 1%, 1/8W, MtF	521/D2	49/C4	DLE	CMF-1/10-634K	R-88-634k
R424	499k, 1%, 1/8W, MtF	521/C1	51/D2	DLE	CMF-1/10	R-88-499k
R425	909k, 1%, 1/8W, MtF	521/D2	52/D3	DLE	CMF-1/10-909K	R-88-909k
R426	47k, 5%, 1/4W, Comp	521/E1	53/D3	BRN	CR25*	R-76-47k
R427	Thick Film	521/Several	54/D3	CAD	--	TF-102-1
R428	1.5k, 1%, 1/8W, MtF	521/F5	55/D3	DLE	DMF-1/10	R-88-1.5k
R429	3.48k, 1%, 1/8W, MtF	521/G5	56/D3	DLE	CMF-1/10	R88-3.48k
R430	10k, 5%, 1/4W, Comp	521/B5	57/E3	BRN	CR25*	R-76-10k
R431	10k, 1%, 1/8W, MtF	521/C2	58/F3	DLE	CMF-1/10	R-88-10k
R432	10k, 5%, 1/4W, Comp	521/B3	59/F3	BRN	CR25*	R-76-10k

**Table 7-9. Filter Mux Board PC-521 Parts List (Cont.)**

Circuit Desig.	Description	Schematic Location	PC-Board Item No./Location	Mfr. Code	Mfr. Desig.	Keithley Part No.
R433	30.1k, 1%, 1/2W, MtF	521/B1	60/F3	DLE	MFF-1/2T-130.1K	R-94-30.1k
R434	100k, 1%, 1/2W, MtF	521/A3	61/F4	CAD	MFF-1/2-1%-100K	R-94-100k
R435	10k, 5%, 1/4W, Comp	521/B1	62/G3	BRN	CR25*	R-76-10k
R436	30.1k, 1%, 1/2W, MtF	521/B1	63/G3	DLE	MFF1/2-T-1-30.1K	R-94-30.1k
R437	100k, 1%, 1/2W, MtF	521/A1	64/G3	CAD	MFF1/2-T-1-100K	R-94-100k
Q401	NPN, TO-92 case	521/G3	68/B3	MOT	2N3904	TG-47
Q402	NPN, TO-92 case	521/G4	69/B3	MOT	2N3906	TG-84
Q403	NPN, TO-92 case	521/F2	70/C3	MOT	2N3904	TG-47
Q404	N-Channel FET	521/F3	71/C3	INT	ITE4392	TG-77
Q405	N-Channel FET	521/F2	72/C3	INT	ITE4392	TG-77
Q406	N-Channel FET	521/D2	73/D2	NAT	PF5301	TG-139
Q407	N-Channel FET	521/E1	74/D2	NAT	PF5301	TG-139
Q408	N-Channel FET	521/E3	75/D2	NAT	PF5301	TG-139
Q409	N-Channel FET	521/E2	76/D2	NAT	PF5301	TG-139
Q410	N-Channel FET	521/E2	77/D3	NAT	PF5301	TG-139
Q411	N-Channel FET	521/E3	78/D3	NAT	PF5301	TG-139
Q412	N-Channel FET	521/E1	79/D3	NAT	PF5301	TG-139
Q413	NPN TO-92 case	521/B5	80/E3	MOT	2N3904	TG-47
U401	OP AMP 8-pin DIP	521/D3	85/B2	NAT	LF351N	IC-176
U402	Voltage Reference	521/D3	86/C2	NAT	LM399	IC-217
U403	OP AMP 8-pin DIP	521/F3	87/C3	NAT	LF351N	IC-176
U404	OP AMP TO-99 case	521/F1	88/C2	A-D	LF356H	IC-218
U405	OP AMP 8-pin DIP	521/D2	89/D2	NAT	LF351	IC-176

\*Manufacturers Designation includes Parts Description - e.g. CR25, 100K, 1%, 1/2W, MtF, R437

\*\*Values selected at factory to match U402.

**Table 7-9. Filter Mux Board PC-521 Parts List (Cont.)**

Circuit Desig.	Description	Schematic Location	PC-Board Item No./Location	Mfr. Code	Mfr. Desig.	Keithley Part No.
U406	Quad Comparator	521/Several	90/D3	NAT	LM339	IC-219
U407	Quad Comparator	521/Several	91/D3	NAT	LM339	IC-219
U408	Flip-Flop	521/E5	92/D4	MOT	74LS374	IC-242
U409	Flip-Flop	521/D5	93/E3	MOT	74LS374	IC-242
U410	Triple-3 Input Nand	521/C5	94/F4	MOT	74LS10	IC-155
W401	Jumper	521/E1	95/F4	K-I	---	J-3
W402	Jumper	521/D2	96/F4	K-I	---	22GA
W403						J-3
CR401	6.3V Zener Diode	521/G3	99/B3	C-I	1N4577	DZ-58
CR402	6.3V Zener Diode	521/G4	100/B3	C-I	1N4577	DZ-58
CR403	5.1V Zener Diode	521/E1	101/D3	SIE	1N751	DZ-59
CR404	Silicon Diode	521/B4	102/E3	T-I	1N914	RF-28
CR405	Silicon Diode	521/B2	103/E2	T-I	1N914	RF-28
CR406	Silicon Diode	521/B2	104/F2	T-I	1N914	RF-28
CR407	Silicon Diode	521/B4	105/F2	T-I	1N914	RF-28
CR408	Silicon Diode	521/C2	106/F3	T-I	1N914	RF-28



**Table 7-10. Fan Assembly Parts List**

Circuit Desig.	Description	Schematic Location	PC-Board Item No./Location	Mfr. Code	Mfr. Desig.	Keithley Part No.
J302	Power Connection	D5	----	K-I	---	CS-325-2
FAN	FAN	D5	---	K-I		FN-7
---	Fan Assembly	--	---	K-I	---	30460C
---	Fan Support Bracket	--	---	K-I	---	30454B
---	Filter Support	--				30458A
---	Filter	--	---	K-I	---	FL-3*
---	Grommet Strip	--	---	K-I	---	28479A-4
---	Tape Cutting	--	---	K-I	---	30858A-1
---	Foam Strips	--	---	K-I	---	TP-6-8
---	Lug	--	---	K-I	---	LU-89

\*The Fan Filter must be kept clean. Dirt in the filter will impede the air flow through the Model 619 and cause overheating. It is recommended to periodically remove the filter and use compressed air to clean it.

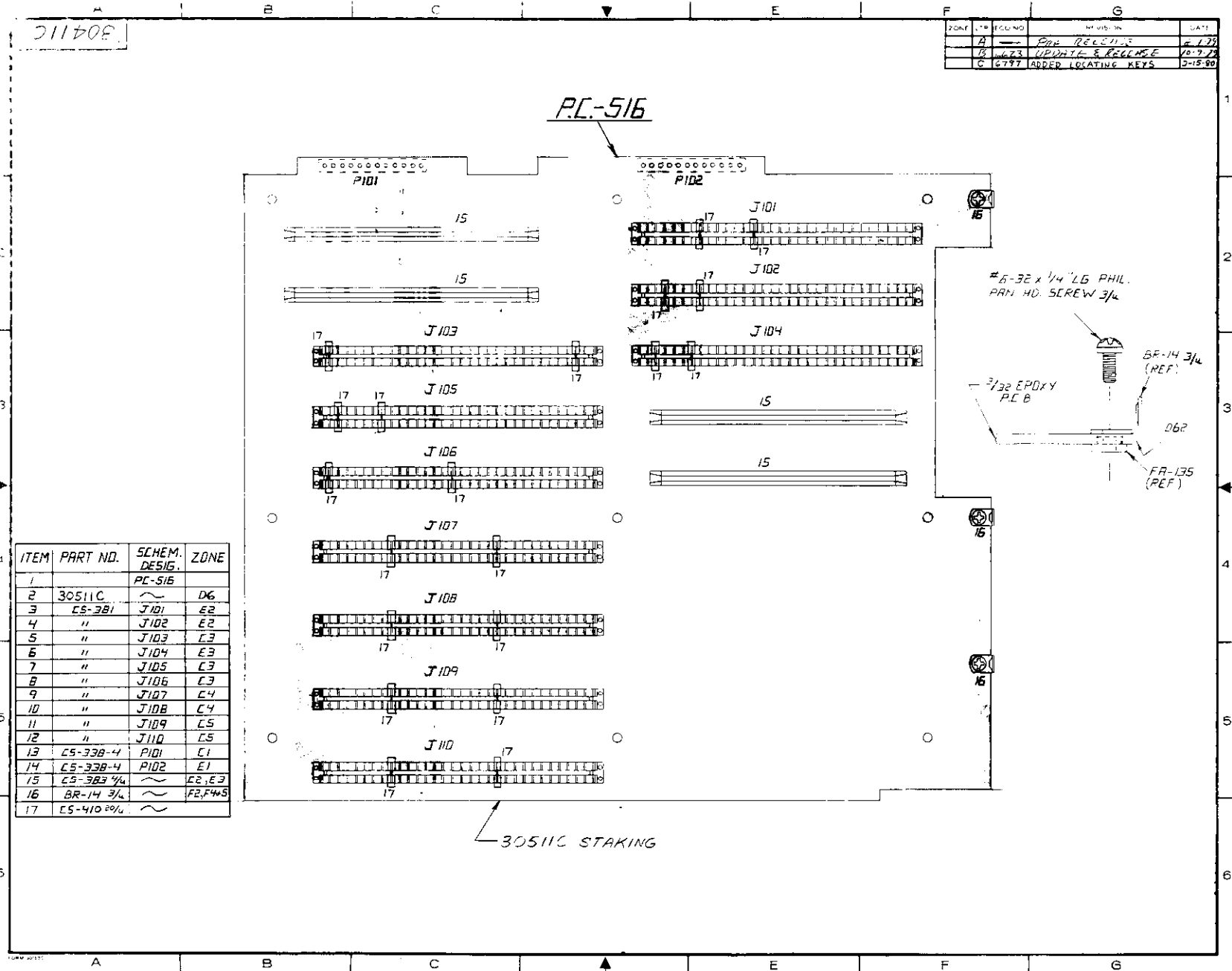

ZONE	FOUND	REVISED	DATE
A		OPR. RECEIVED	1-1-79
B	1673	UPDATE & REVERSE	10-9-78
C	1677	ADDED LOCATING KEYS	3-15-80

ITEM	PART NO.	SCHEM. DESIG.	ZONE
1		PC-516	
2	30511C	~	D6
3	CS-381	J101	E2
4	"	J102	E2
5	"	J103	E3
6	"	J104	E3
7	"	J105	E3
8	"	J106	E3
9	"	J107	E4
10	"	J108	E4
11	"	J109	E5
12	"	J110	E5
13	CS-338-4	P101	E1
14	CS-338-4	P102	E1
15	CS-383 3/4	~	E2, E3
16	BR-14 3/4	~	F2, F4+S
17	CS-410 20/4	~	

30411C

PC-516

30511C STAKING

7-31/7-32

Figure 7-1. Mother Board PC-516, Component Location Drawing, Dwg. No. 30411C

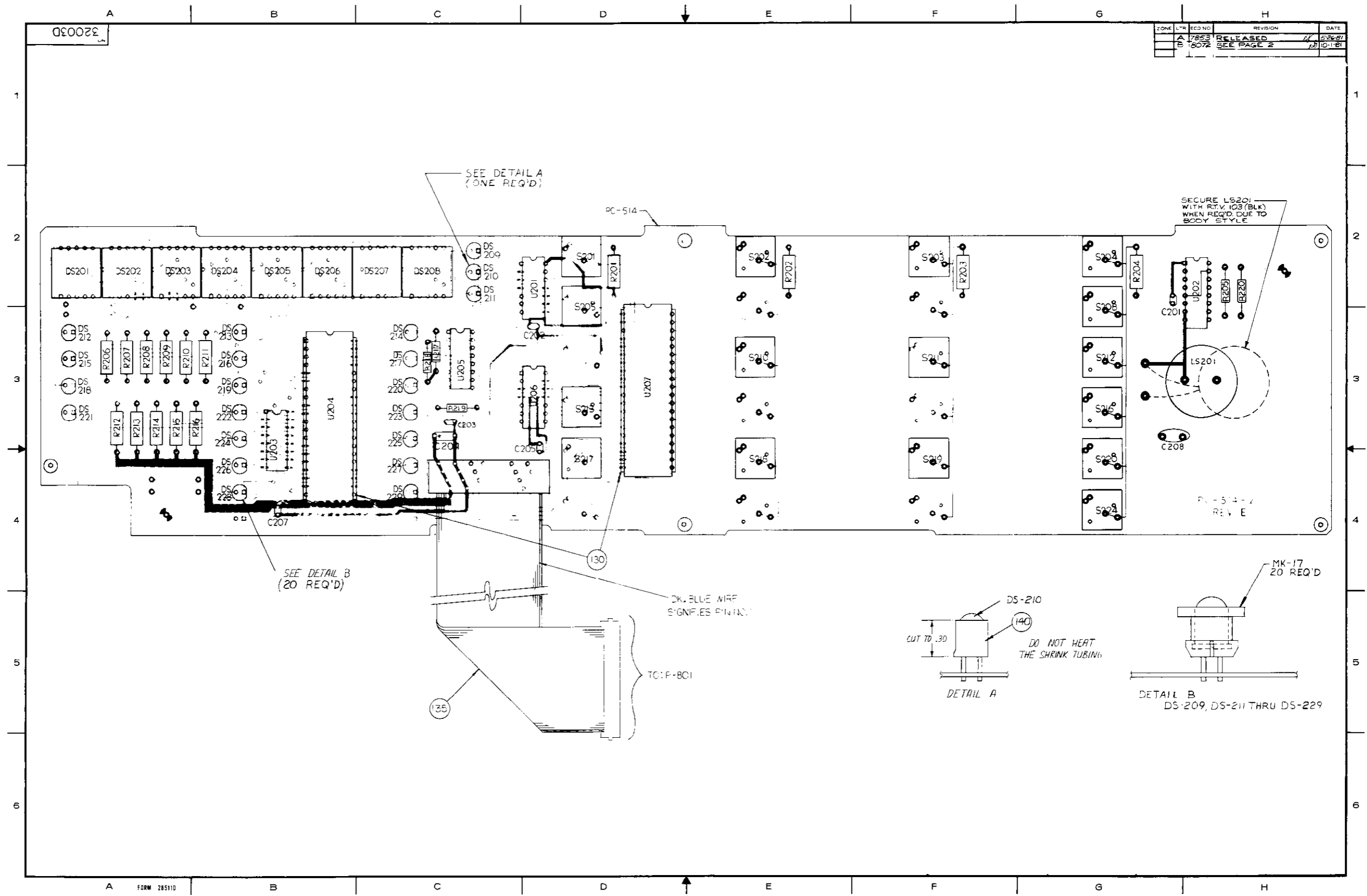

Figure 7-2. Display Board PC-514, Component Location Drawing, Dwg. No. 32003 (sheet 1 of 2)

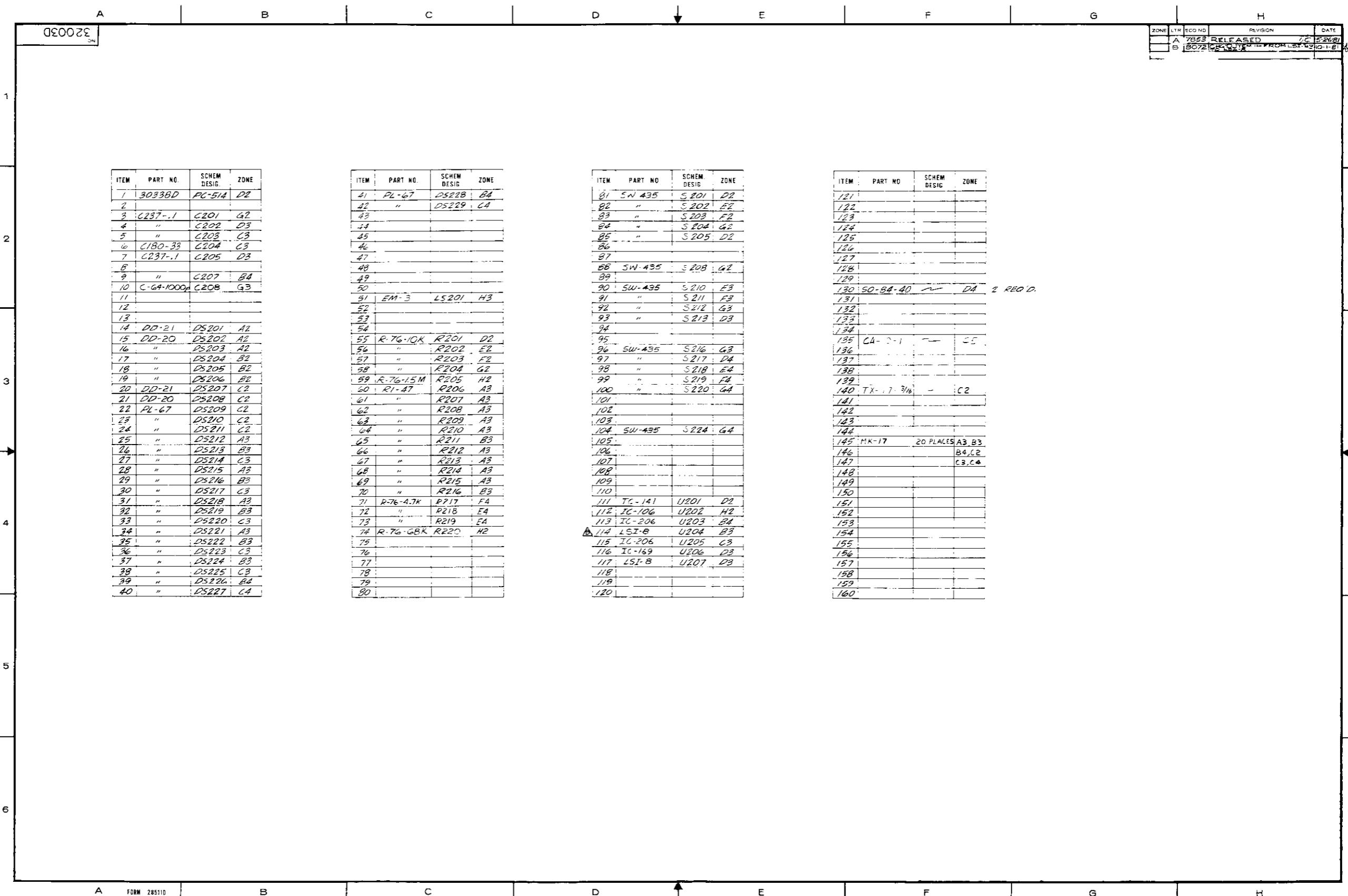

Figure 7-2. Display Board PC-514, Component Location Drawing, Dwg. No. 32003 (sheet 2 of 2)

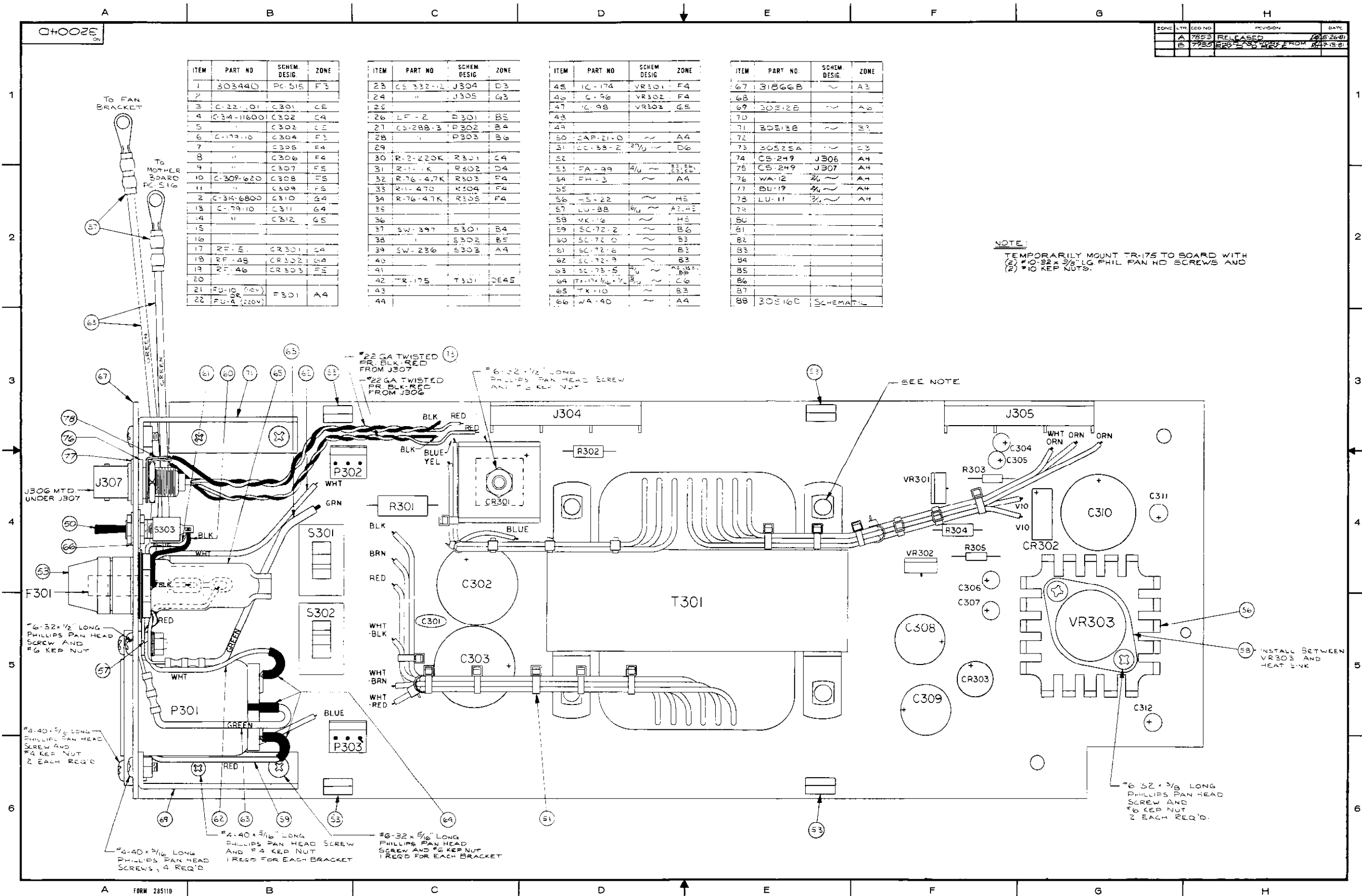

Figure 7-3. Power Supply Board PC-515, Component Location Drawing, Dwg. No. 32004

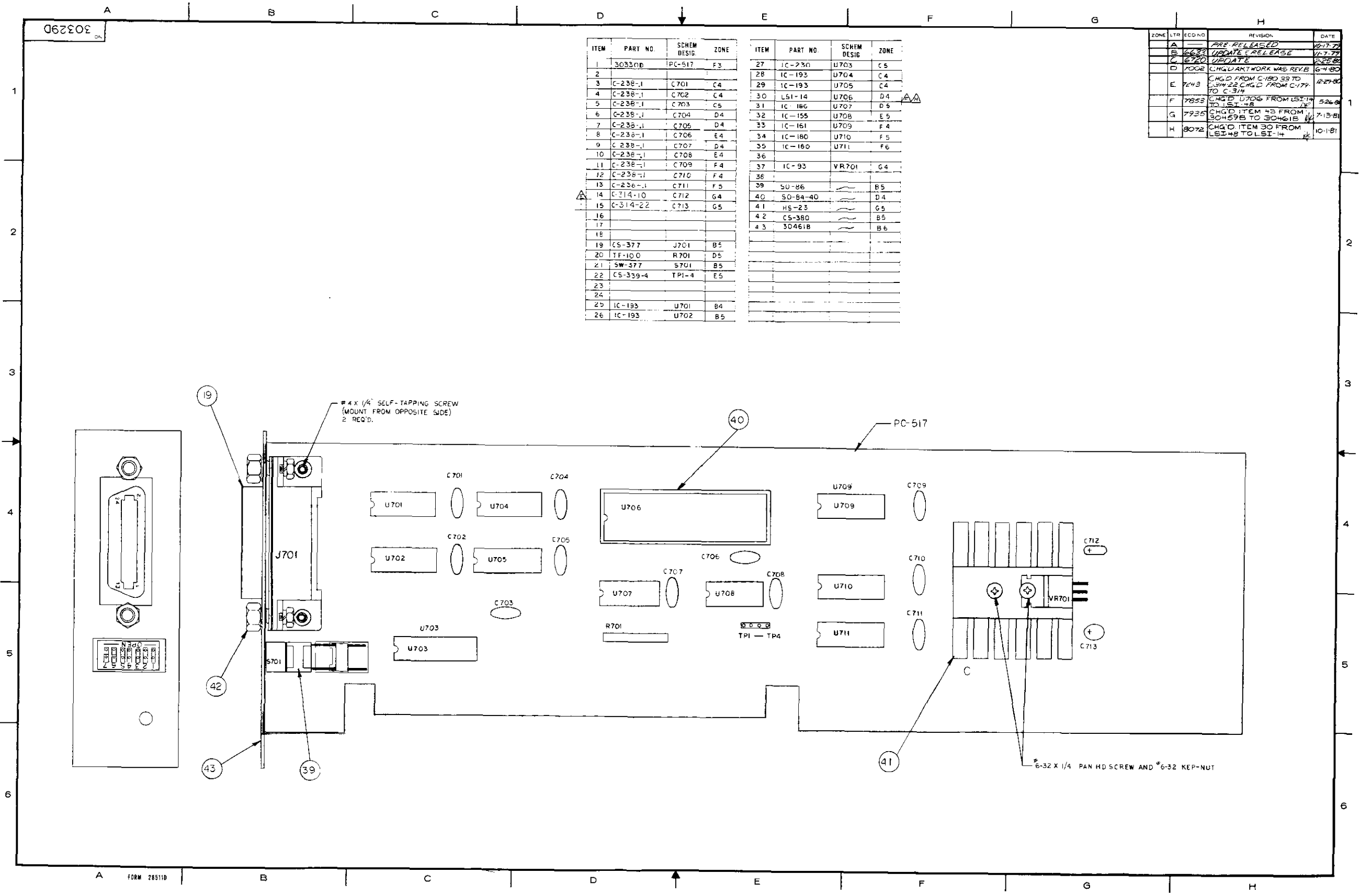
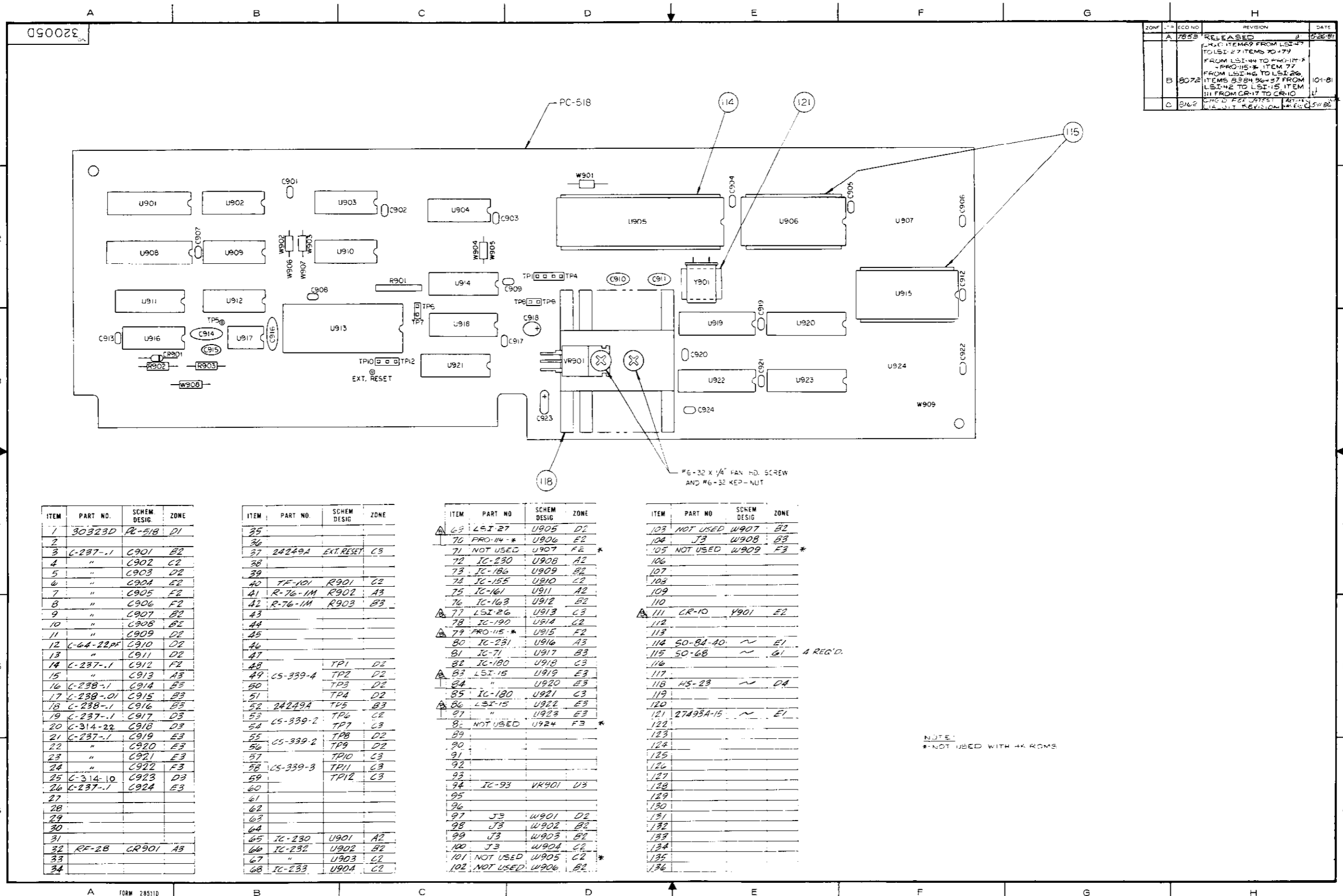

Figure 7-4. IEEE Interface Board PC-517, Component Location Drawing, Dwg. No. 30329



ZONE	ECO NO.	REVISION	DATE
A	7853	RELEASED	10-26-81
B	8072	LSI-42 ITEMS FROM LSI-49 TO LSI-27 ITEMS 70-79 FROM LSI-44 TO PRO-117 FROM PRO-115-8 ITEM 77 FROM LSI-46 TO LSI-26 ITEMS 89-94 96-97 FROM LSI-42 TO LSI-15 ITEM 111 FROM CR-17 TO CR-10	10-1-81
C	8162	CRIC 2 FOR TEST TABLES LSI UNIT REVISION FROM C-5178	

ITEM	PART NO.	SCHEM DESIG	ZONE
1	30323D	PC-518	D1
2			
3	C-237-1	C901	B2
4	"	C902	C2
5	"	C903	D2
6	"	C904	E2
7	"	C905	F2
8	"	C906	F2
9	"	C907	B2
10	"	C908	B2
11	"	C909	D2
12	C-64-22PF	C910	D2
13	"	C911	D2
14	C-237-1	C912	F2
15	"	C913	A3
16	C-238-1	C914	B3
17	C-238-01	C915	B3
18	C-238-1	C916	B3
19	C-237-1	C917	D3
20	C-314-22	C918	D3
21	C-237-1	C919	E3
22	"	C920	E3
23	"	C921	E3
24	"	C922	F3
25	C-314-10	C923	D3
26	C-237-1	C924	E3
27			
28			
29			
30			
31			
32	RF-2B	CR901	A3
33			
34			

ITEM	PART NO.	SCHEM DESIG	ZONE
35			
36			
37	24249A	EXT. RESET	C3
38			
39			
40	TF-101	R901	C2
41	R-76-1M	R902	A3
42	R-76-1M	R903	B3
43			
44			
45			
46			
47			
48		TP1	D2
49	CS-339-4	TP2	D2
50		TP3	D2
51		TP4	D2
52	24249A	TP5	B3
53		TP6	C2
54	CS-339-2	TP7	C2
55	CS-339-2	TP8	D2
56		TP9	D2
57		TP10	C3
58	CS-339-3	TP11	C3
59		TP12	C3
60			
61			
62			
63			
64			
65	IC-230	U901	A2
66	IC-232	U902	B2
67	"	U903	C2
68	IC-233	U904	C2

ITEM	PART NO.	SCHEM DESIG	ZONE
69	LSI-27	U905	D2
70	PRO-114 *	U906	E2
71	NOT USED	U907	F2 *
72	IC-230	U908	A2
73	IC-186	U909	B2
74	IC-155	U910	C2
75	IC-161	U911	A2
76	IC-163	U912	B2
77	LSI-26	U913	C3
78	IC-190	U914	C2
79	PRO-115 *	U915	F2
80	IC-231	U916	A3
81	IC-71	U917	B3
82	IC-180	U918	C3
83	LSI-15	U919	E3
84	"	U920	E3
85	IC-180	U921	C3
86	LSI-15	U922	E3
87	"	U923	E3
88	NOT USED	U924	F3 *
89			
90			
91			
92			
93			
94	IC-93	VR901	U3
95			
96			
97	J3	W901	D2
98	J3	W902	B2
99	J3	W903	B2
100	J3	W904	C2
101	NOT USED	W905	C2 *
102	NOT USED	W906	B2

ITEM	PART NO.	SCHEM DESIG	ZONE
103	NOT USED	W907	B2
104	J3	W908	B3
105	NOT USED	W909	F3 *
106			
107			
108			
109			
110			
111	CR-10	Y901	E2
112			
113			
114	50-84-40	~	E1
115	50-68	~	B1 A REQ'D
116			
117			
118	45-23	~	DA
119			
120			
121	27493A-15	~	E1
122			
123			
124			
125			
126			
127			
128			
129			
130			
131			
132			
133			
134			
135			
136			

NOTE:  
\*NOT USED WITH 4K ROMS

Figure 7-5. Processor Board PC-518, Component Location Drawing, Dwg. No. 32005

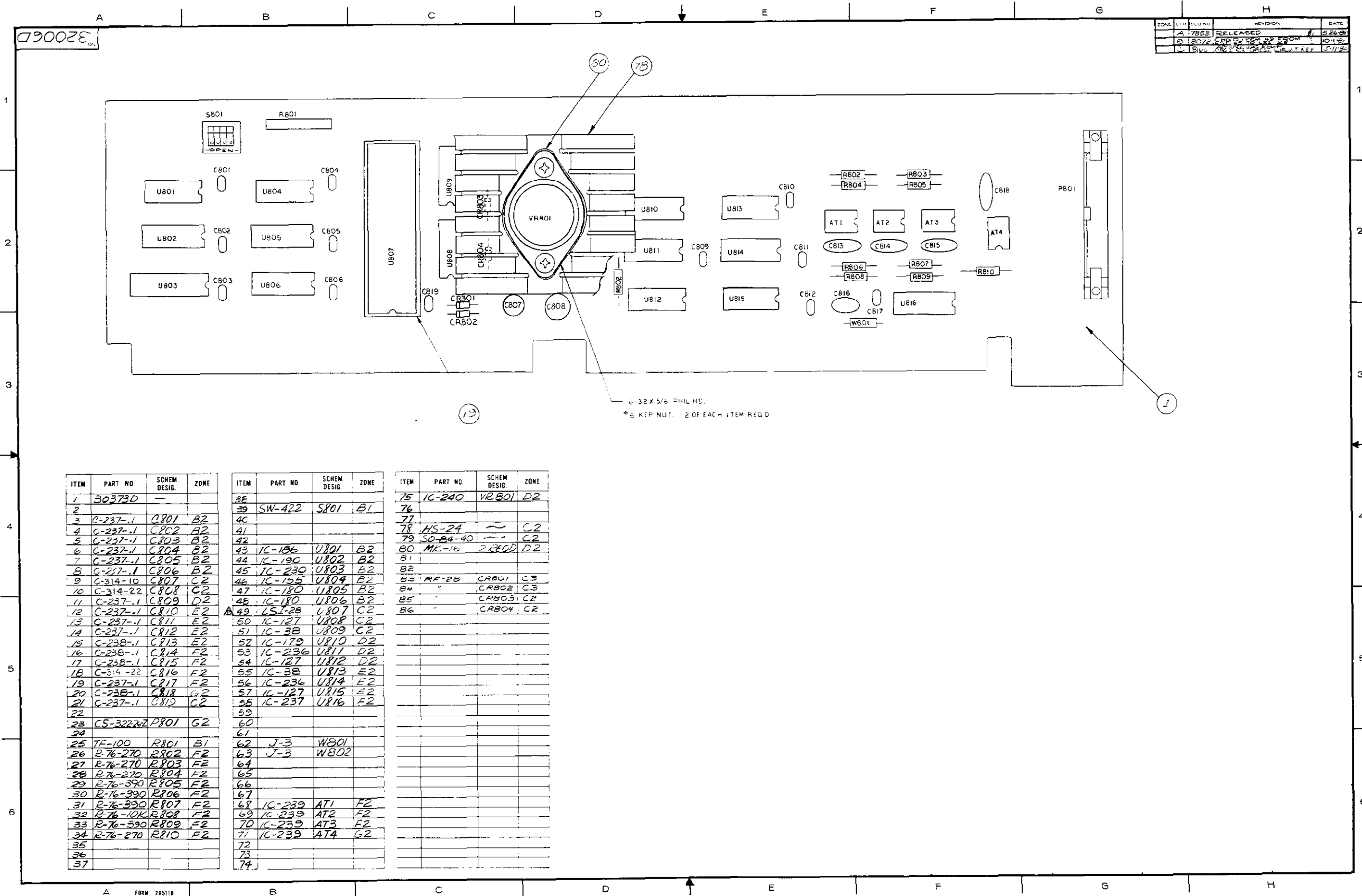

ZONE	ITEM	REVISION	DATE
A	7855	RELEASED	5/26/68
B	8077	CREATED FROM	10/1/68
C	8077	REVISED	1/1/69

ITEM	PART NO.	SCHEM. DESIG.	ZONE	ITEM	PART NO.	SCHEM. DESIG.	ZONE	ITEM	PART NO.	SCHEM. DESIG.	ZONE
1	30373D			38				75	IC-240	VR401	D2
2				39	SW-422	S801	B1	76			
3	C-237-1	C801	B2	40				77			
4	C-237-1	C802	B2	41				78	HS-24		C2
5	C-237-1	C803	B2	42				79	SD-84-40		C2
6	C-237-1	C804	B2	43	IC-186	U801	B2	80	MC-16	2.000D	D2
7	C-237-1	C805	B2	44	IC-190	U802	B2	81			
8	C-217-1	C806	B2	45	IC-230	U803	B2	82			
9	C-314-10	C807	C2	46	IC-195	U804	B2	83	RF-28	CR801	C3
10	C-314-22	C808	C2	47	IC-180	U805	B2	84		CR802	C3
11	C-237-1	C809	D2	48	IC-180	U806	B2	85		CR803	C2
12	C-237-1	C810	E2	49	LSI-28	U807	C2	86		CR804	C2
13	C-237-1	C811	E2	50	IC-127	U808	C2				
14	C-237-1	C812	E2	51	IC-38	U809	C2				
15	C-238-1	C813	E2	52	IC-179	U810	D2				
16	C-238-1	C814	F2	53	IC-236	U811	D2				
17	C-238-1	C815	F2	54	IC-127	U812	D2				
18	C-314-22	C816	F2	55	IC-38	U813	E2				
19	C-237-1	C817	F2	56	IC-236	U814	E2				
20	C-238-1	C818	G2	57	IC-127	U815	E2				
21	C-237-1	C819	C2	58	IC-237	U816	F2				
22				59							
23	CS-32226Z	P801	G2	60							
24				61							
25	TF-100	R801	B1	62	J-3	W801					
26	R-76-270	R802	F2	63	J-3	W802					
27	R-76-270	R803	F2	64							
28	R-76-270	R804	F2	65							
29	R-76-390	R805	F2	66							
30	R-76-390	R806	F2	67							
31	R-76-390	R807	F2	68	IC-239	AT1	F2				
32	R-76-10K	R808	F2	69	IC-239	AT2	F2				
33	R-76-590	R809	F2	70	IC-239	AT3	F2				
34	R-76-270	R810	F2	71	IC-239	AT4	G2				
35				72							
36				73							
37				74							

Figure 7-6. Isolator Board PC-519, Component Location Drawing, Dwg. No. 32006



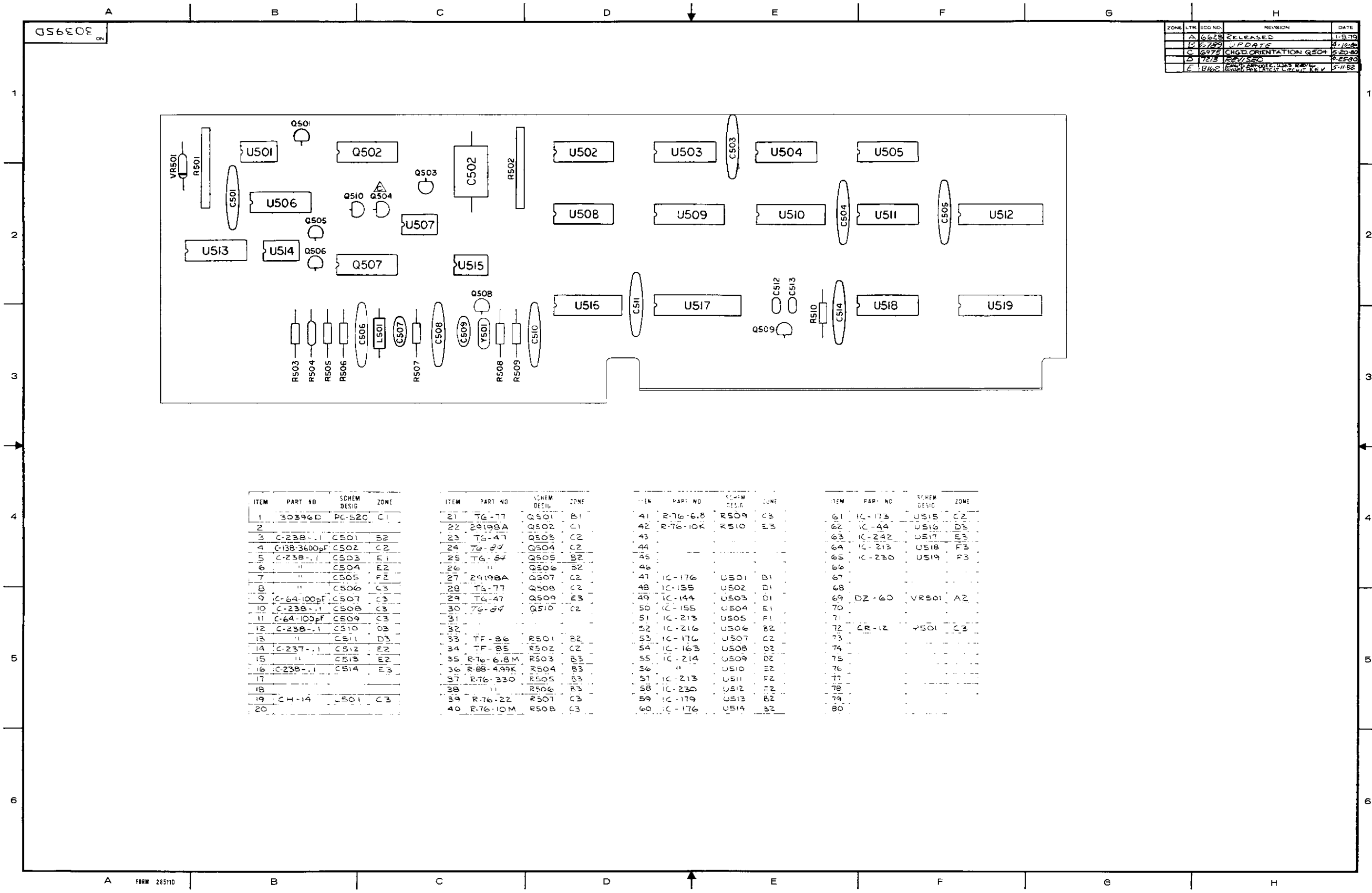

ITEM	PART NO	SCHEM DESIG	ZONE
1	30396D	PC-520	C1
2			
3	C-238-.1	C501	B2
4	C-138-3600pF	C502	C2
5	C-238-.1	C503	E1
6	"	C504	E2
7	"	C505	F2
8	"	C506	C3
9	C-64-100pF	C507	C3
10	C-238-.1	C508	C3
11	C-64-100pF	C509	C3
12	C-238-.1	C510	D3
13	"	C511	D3
14	C-237-.1	C512	E2
15	"	C513	E2
16	C-238-.1	C514	F3
17			
18			
19	CH-14	L501	C3
20			

ITEM	PART NO	SCHEM DESIG	ZONE
21	TG-77	Q501	B1
22	29198A	Q502	C1
23	TG-47	Q503	C2
24	TG-84	Q504	C2
25	TG-84	Q505	B2
26	"	Q506	B2
27	29198A	Q507	C2
28	TG-77	Q508	C2
29	TG-47	Q509	E3
30	TG-84	Q510	C2
31			
32			
33	TF-B6	R501	B2
34	TF-B6	R502	C2
35	R-76-6.8M	R503	B3
36	R-88-4.99K	R504	B3
37	R-76-330	R505	B3
38	"	R506	B3
39	R-76-22	R507	C3
40	R-76-10M	R508	C3

ITEM	PART NO	SCHEM DESIG	ZONE
41	R-76-6.8	R509	C3
42	R-76-10K	R510	E3
43			
44			
45			
46			
47	IC-176	U501	B1
48	IC-155	U502	D1
49	IC-144	U503	D1
50	IC-155	U504	E1
51	IC-213	U505	F1
52	IC-216	U506	B2
53	IC-176	U507	C2
54	IC-163	U508	B2
55	IC-214	U509	D2
56	"	U510	E2
57	IC-213	U511	F2
58	IC-230	U512	C2
59	IC-179	U513	B2
60	IC-176	U514	B2

ITEM	PART NO	SCHEM DESIG	ZONE
61	IC-173	U515	C2
62	IC-44	U516	D3
63	IC-242	U517	E3
64	IC-213	U518	F3
65	IC-230	U519	F3
66			
67			
68			
69	DZ-60	VR501	A2
70			
71			
72	CR-12	Y501	C3
73			
74			
75			
76			
77			
78			
79			
80			

Figure 7-7. A/D Converter Board PC-520, Component Location Drawing, Dwg. No. 30395

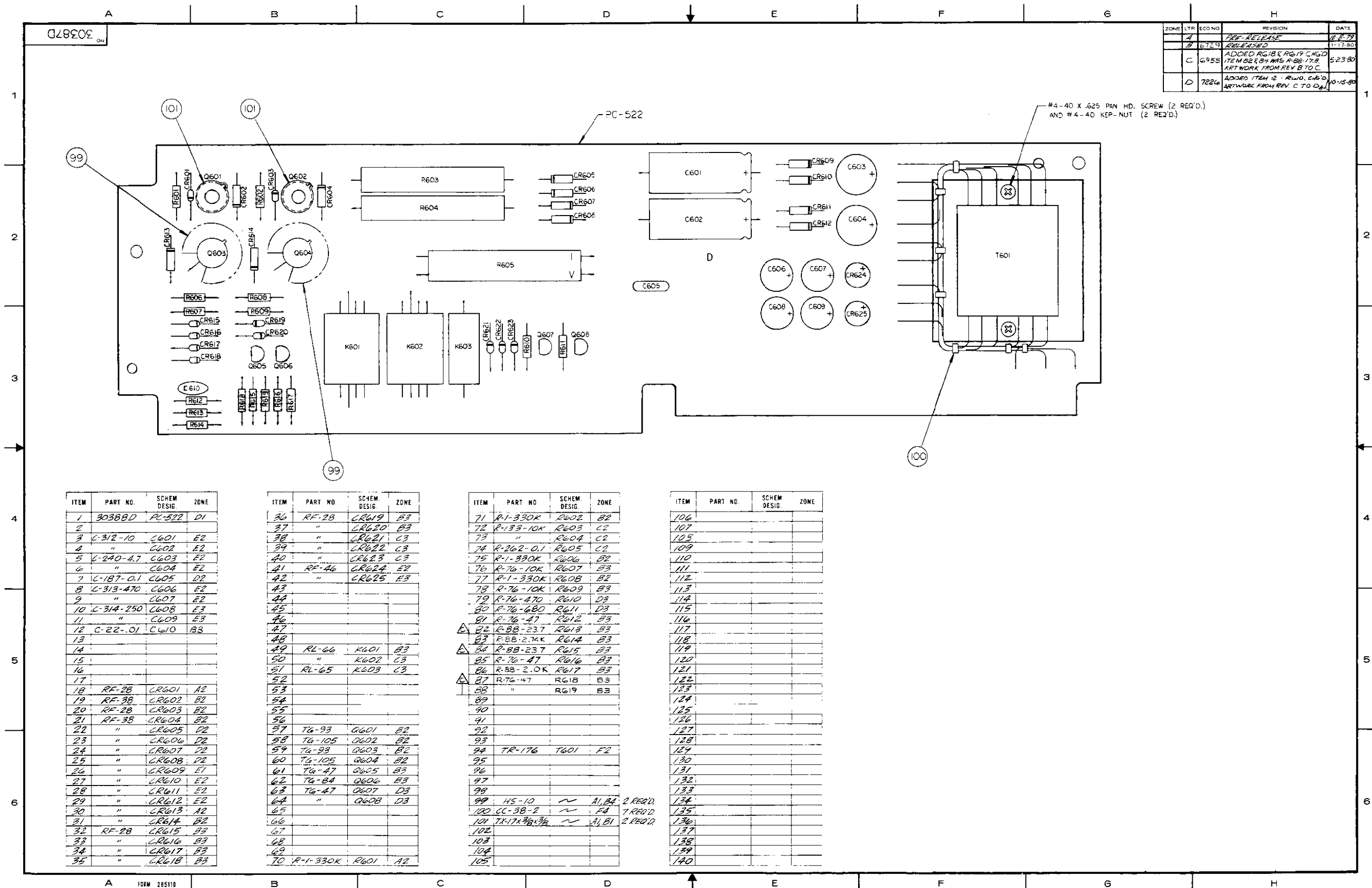

ZONE	LYR	ECD NO.	REVISION	DATE
A			PRE-RELEASE	12-8-79
B	6129		RELEASED	11-17-80
C	6955		ADDED RG18 & RG19 C460 ITEM B2 & B4 WAS A-BB-178 ART WORK FROM REV B TO C	5-23-80
D	7226		ADDED ITEM 12 - R40, C460 ARTWORK FROM REV C TO D	10-15-80

ITEM	PART NO.	SCHEM DESIG.	ZONE
1	30388D	PC-522	D1
2			
3	C-312-10	C601	E2
4	"	C602	E2
5	C-240-47	C603	E2
6	"	C604	E2
7	C-187-0.1	C605	D2
8	C-313-470	C606	E2
9	"	C607	E2
10	C-314-250	C608	E3
11	"	C609	E3
12	C-22-0.1	C610	B3
13			
14			
15			
16			
17			
18	RF-28	CR601	A2
19	RF-38	CR602	B2
20	RF-28	CR603	B2
21	RF-38	CR604	B2
22	"	CR605	D2
23	"	CR606	D2
24	"	CR607	D2
25	"	CR608	D2
26	"	CR609	E1
27	"	CR610	E2
28	"	CR611	E2
29	"	CR612	E2
30	"	CR613	A2
31	"	CR614	B2
32	RF-28	CR615	B3
33	"	CR616	B3
34	"	CR617	B3
35	"	CR618	B3

ITEM	PART NO.	SCHEM DESIG.	ZONE
36	RF-28	CR619	B3
37	"	CR620	B3
38	"	CR621	C3
39	"	CR622	C3
40	"	CR623	C3
41	RF-46	CR624	E2
42	"	CR625	E3
43			
44			
45			
46			
47			
48			
49	RL-66	K601	B3
50	"	K602	C3
51	RL-65	K603	C3
52			
53			
54			
55			
56			
57	T6-93	Q601	B2
58	T6-105	Q602	B2
59	T6-93	Q603	B2
60	T6-105	Q604	B2
61	T6-47	Q605	B3
62	T6-84	Q606	B3
63	T6-47	Q607	D3
64	"	Q608	D3
65			
66			
67			
68			
69			
70	R-1-330K	R601	A2

ITEM	PART NO.	SCHEM DESIG.	ZONE
71	R-1-330K	R602	B2
72	R-133-10K	R603	C2
73	"	R604	C2
74	R-262-0.1	R605	C2
75	R-1-330K	R606	B2
76	R-76-10K	R607	B3
77	R-1-330K	R608	B2
78	R-76-10K	R609	B3
79	R-76-470	R610	D3
80	R-76-680	R611	D3
81	R-76-47	R612	B3
82	R-88-237	R613	B3
83	R-88-2.74K	R614	B3
84	R-88-237	R615	B3
85	R-76-47	R616	B3
86	R-88-2.0K	R617	B3
87	R-76-47	R618	B3
88	"	R619	B3
89			
90			
91			
92			
93			
94	TR-176	T601	F2
95			
96			
97			
98			
99	H5-10	~	A1, B4 2 REQ'D.
100	CC-38-2	~	FA 7 REQ'D.
101	TR-176X3/8	~	A1, B1 2 REQ'D.
102			
103			
104			
105			

ITEM	PART NO.	SCHEM DESIG.	ZONE
106			
107			
108			
109			
110			
111			
112			
113			
114			
115			
116			
117			
118			
119			
120			
121			
122			
123			
124			
125			
126			
127			
128			
129			
130			
131			
132			
133			
134			
135			
136			
137			
138			
139			
140			

Figure 7-8. Electrometer Module Board PC-522, Component Location Drawing, Dwg. No. 30387

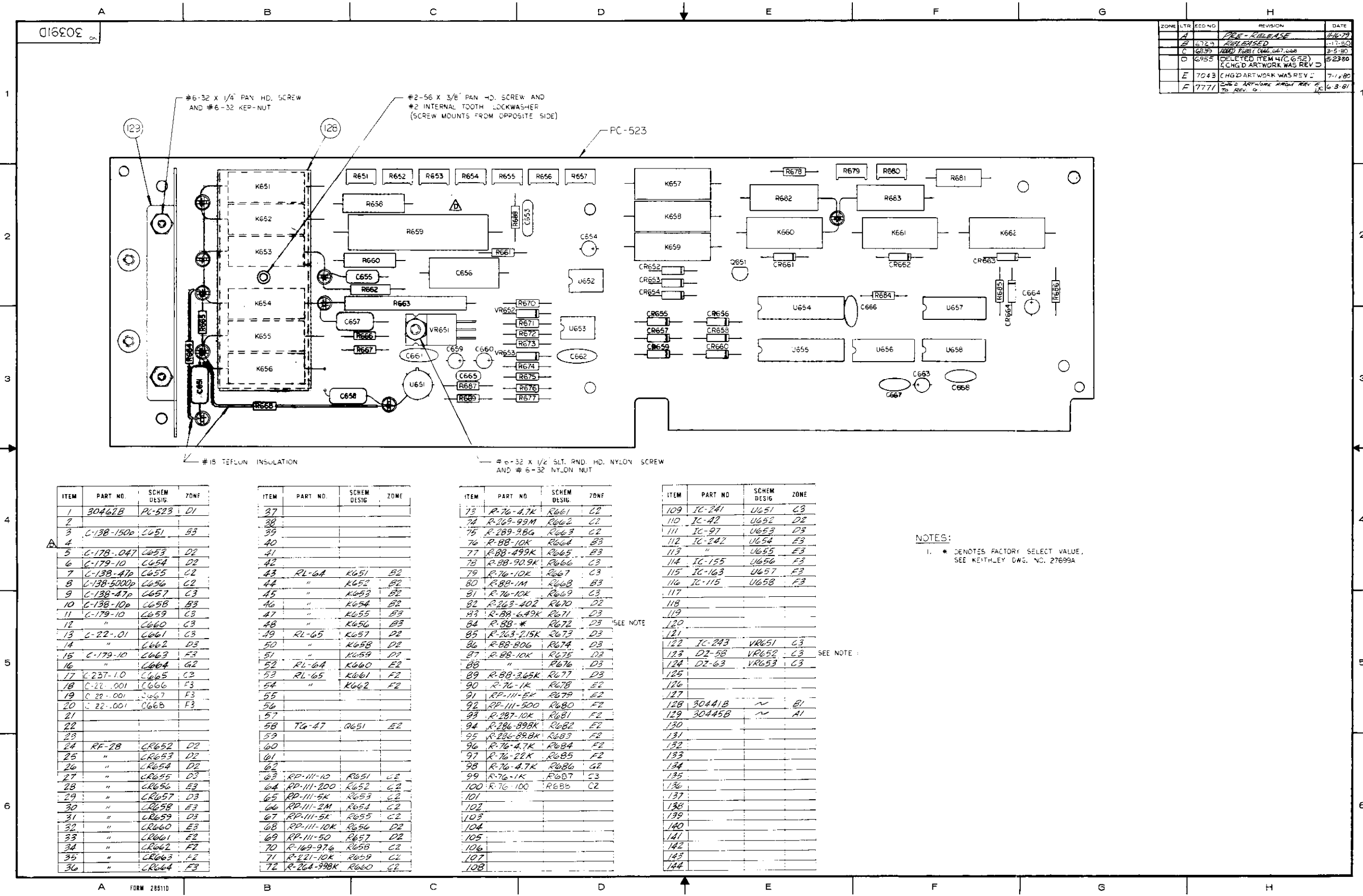

ITEM	PART NO.	SCHEM DESIG	ZONE
1	30462B	PC-523	D1
2			
3	C-138-150p	U651	B3
4			
5	C-178-.047	C653	D2
6	C-179-10	C654	D2
7	C-138-47p	C655	C2
8	C-138-5000p	C656	C2
9	C-138-47p	C657	C3
10	C-138-10p	C658	B3
11	C-179-10	C659	C3
12		C660	C3
13	C-22-.01	C661	C3
14		C662	D3
15	C-179-10	C663	F3
16		C664	G2
17	C-237-1.0	C665	C3
18	C-22-.001	C666	F3
19	C-22-.001	C667	F3
20	C-22-.001	C668	F3
21			
22			
23			
24	RF-28	CR652	D2
25		CR653	D2
26		CR654	D2
27		CR655	D3
28		CR656	E3
29		CR657	D3
30		CR658	E3
31		CR659	D3
32		CR660	E3
33		CR661	E2
34		CR662	F2
35		CR663	F2
36		CR664	F3

ITEM	PART NO.	SCHEM DESIG	ZONE
37			
38			
39			
40			
41			
42			
43	RL-6A	K651	B2
44	"	K652	B2
45	"	K653	B2
46	"	K654	B2
47	"	K655	B3
48	"	K656	B3
49	RL-65	K657	D2
50	"	K658	D2
51	"	K659	D2
52	RL-6A	K660	E2
53	RL-65	K661	F2
54	"	K662	F2
55			
56			
57			
58	TG-47	U651	E2
59			
60			
61			
62			
63	RP-111-10	R651	C2
64	RP-111-200	R652	C2
65	RP-111-5K	R653	C2
66	RP-111-2M	R654	C2
67	RP-111-5K	R655	C2
68	RP-111-10K	R656	D2
69	RP-111-50	R657	D2
70	R-169-976	R658	C2
71	R-221-10K	R659	C2
72	R-26A-998K	R660	C2

ITEM	PART NO.	SCHEM DESIG	ZONE
73	R-76-47K	R661	C2
74	R-269-99M	R662	C2
75	R-289-98G	R663	C2
76	R-88-10K	R664	B3
77	R-88-499K	R665	B3
78	R-88-909K	R666	C3
79	R-76-10K	R667	C3
80	R-88-1M	R668	B3
81	R-76-10K	R669	C3
82	R-263-202	R670	D2
83	R-88-649K	R671	D3
84	R-88-*	R672	D3
85	R-263-715K	R673	D3
86	R-88-806	R674	D3
87	R-88-10K	R675	D3
88	"	R676	D3
89	R-88-3.65K	R677	D3
90	R-76-1K	R678	E2
91	RP-111-5K	R679	E2
92	RP-111-500	R680	F2
93	R-287-10K	R681	F2
94	R-286-898K	R682	E2
95	R-286-898K	R683	E2
96	R-76-47K	R684	F2
97	R-76-22K	R685	F2
98	R-76-47K	R686	G2
99	R-76-1K	R687	C3
100	R-76-100	R688	C2

ITEM	PART NO.	SCHEM DESIG	ZONE
109	IC-241	U651	C3
110	IC-42	U652	D2
111	IC-97	U653	D3
112	IC-242	U654	E3
113	"	U655	E3
114	IC-155	U656	F3
115	IC-163	U657	F3
116	IC-115	U658	F3
117			
118			
119			
120			
121			
122	IC-243	VR651	C3
123	D2-58	VR652	C3
124	D2-63	VR653	C3
125			
126			
127			
128	30441B		B1
129	30445B		A1
130			
131			
132			
133			
134			
135			
136			
137			
138			
139			
140			
141			
142			
143			
144			

NOTES:  
 1. \* DENOTES FACTORY SELECT VALUE. SEE KEITHLEY DWG. NO. 27699A

Figure 7-8. Electrometer Module Board PC-523, Component Location Drawing, Dwg. No. 30391

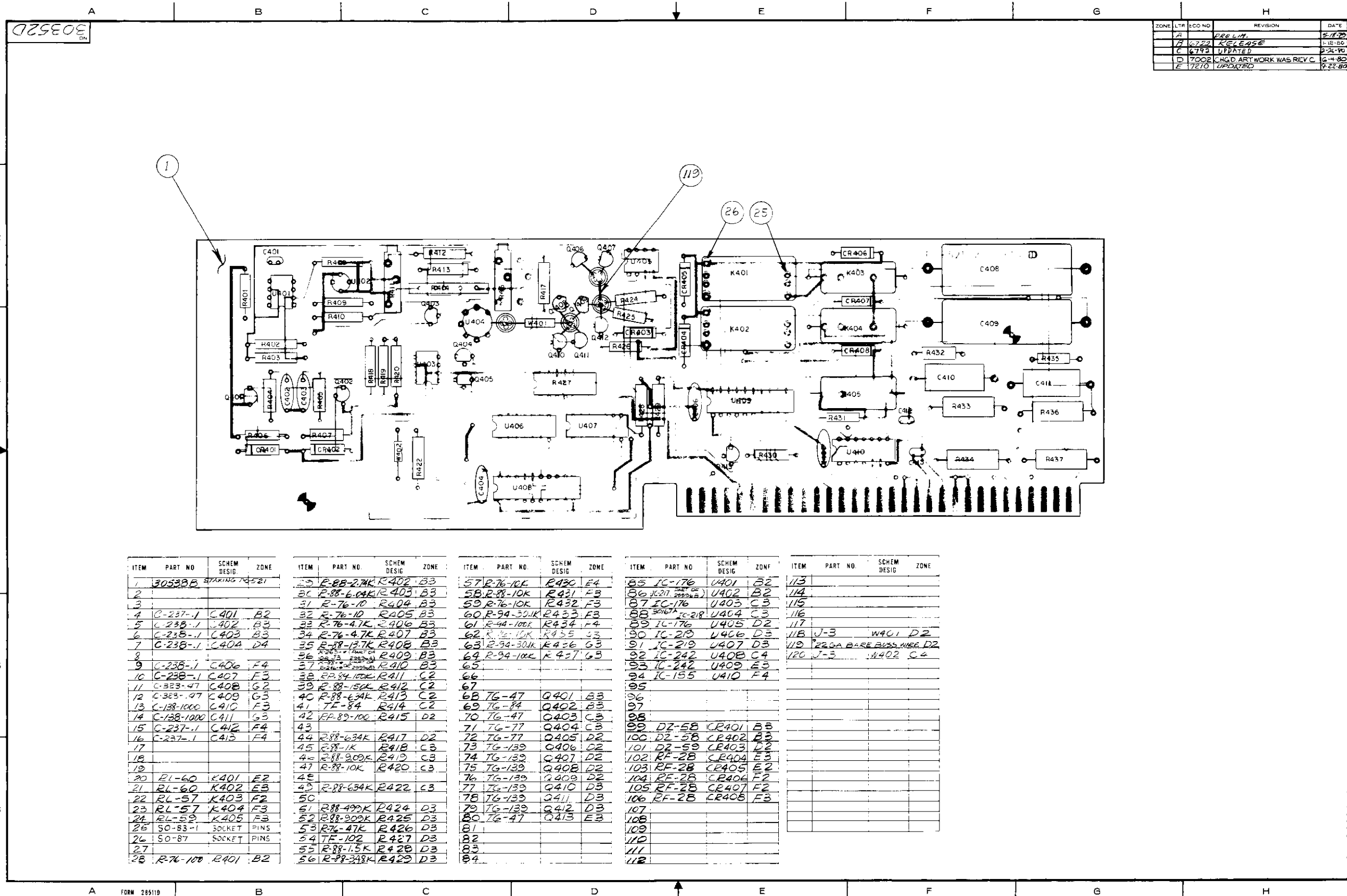

ZONE	LTR	ECO NO	REVISION	DATE
A			PRELIM.	5-17-70
B	6722		RELEASE	1-18-80
C	6793		UPDATED	2-24-80
D	7002		CHG. ART WORK WAS REV. C	6-4-80
E	7270		UPDATED	7-23-80

ITEM	PART NO	SCHEM DESIG	ZONE	ITEM	PART NO	SCHEM DESIG	ZONE	ITEM	PART NO	SCHEM DESIG	ZONE	ITEM	PART NO	SCHEM DESIG	ZONE	ITEM	PART NO	SCHEM DESIG	ZONE
1	30352D	STARTING PC-521		29	R-88-274K	R402	B3	57	R-76-10K	R430	F4	85	IC-176	U401	B2	113			
2				30	R-88-6.04K	R403	B3	58	R-88-10K	R431	F3	86	IC-219	U402	B2	114			
3				31	R-76-10	R404	B3	59	R-76-10K	R432	F3	87	IC-176	U403	C3	115			
4	C-237-1	C401	B2	32	R-76-10	R405	B3	60	R-94-301K	R433	F3	88	IC-219	U404	C3	116			
5	C-238-1	C402	B3	33	R-76-4.1K	R406	B3	61	R-44-100K	R434	F4	89	IC-176	U405	D2	117			
6	C-238-1	C403	B3	34	R-76-4.7K	R407	B3	62	R-44-100K	R435	F3	90	IC-219	U406	D3	118	J-3	W401	D2
7	C-238-1	C404	D4	35	R-88-13.7K	R408	B3	63	R-94-301K	R436	G3	91	IC-219	U407	D3	119	22 GA BARE BRASS WIRE		D2
8				36	R-88-150K	R409	B3	64	R-94-100K	R437	G3	92	IC-242	U408	C4	120	J-3	W402	C4
9	C-238-1	C406	F4	37	R-88-150K	R410	B3	65				93	IC-242	U409	E3				
10	C-238-1	C407	F3	38	R-88-150K	R411	C2	66				94	IC-155	U410	F4				
11	C-323-47	C408	G2	39	R-88-150K	R412	C2	67				95							
12	C-323-47	C409	G3	40	R-88-634K	R413	C2	68	TG-47	Q401	B3	96							
13	C-138-1000	C410	F3	41	TF-84	R414	C2	69	TG-84	Q402	B3	97							
14	C-138-1000	C411	G3	42	RF-89-100	R415	D2	70	TG-47	Q403	C3	98							
15	C-237-1	C412	F4	43	R-88-634K	R417	D2	71	TG-77	Q404	C3	99	DZ-58	CR401	B3				
16	C-237-1	C413	F4	44	R-88-1K	R418	C3	72	TG-77	Q405	D2	100	DZ-58	CR402	B3				
17				45	R-88-1K	R419	C3	73	TG-139	Q406	D2	101	DZ-59	CR403	D2				
18				46	R-88-909K	R419	C3	74	TG-139	Q407	D2	102	RF-28	CR404	E3				
19				47	R-88-10K	R420	C3	75	TG-139	Q408	D2	103	RF-28	CR405	E2				
20	RL-60	K401	E2	48				76	TG-139	Q409	D2	104	RF-28	CR406	F2				
21	RL-60	K402	E3	49	R-88-634K	R422	C3	77	TG-139	Q410	D3	105	RF-28	CR407	F2				
22	RL-57	K403	F2	50				78	TG-139	Q411	D3	106	RF-28	CR408	F3				
23	RL-57	K404	F3	51	R-88-499K	R424	D3	79	TG-139	Q412	D3	107							
24	RL-52	K405	F3	52	R-88-909K	R425	D3	80	TG-47	Q413	E3	108							
25	SO-83-1	SOCKET PINS		53	R-76-47K	R426	D3	81				109							
26	SO-87	SOCKET PINS		54	TF-102	R427	D3	82				110							
27				55	R-88-1.5K	R428	D3	83				111							
28	R-76-100	R401	B2	56	R-88-348K	R429	D3	84				112							

Figure 7-9. Filter Mux Board PC-521. Component Location Drawing, Dwg. No. 30352

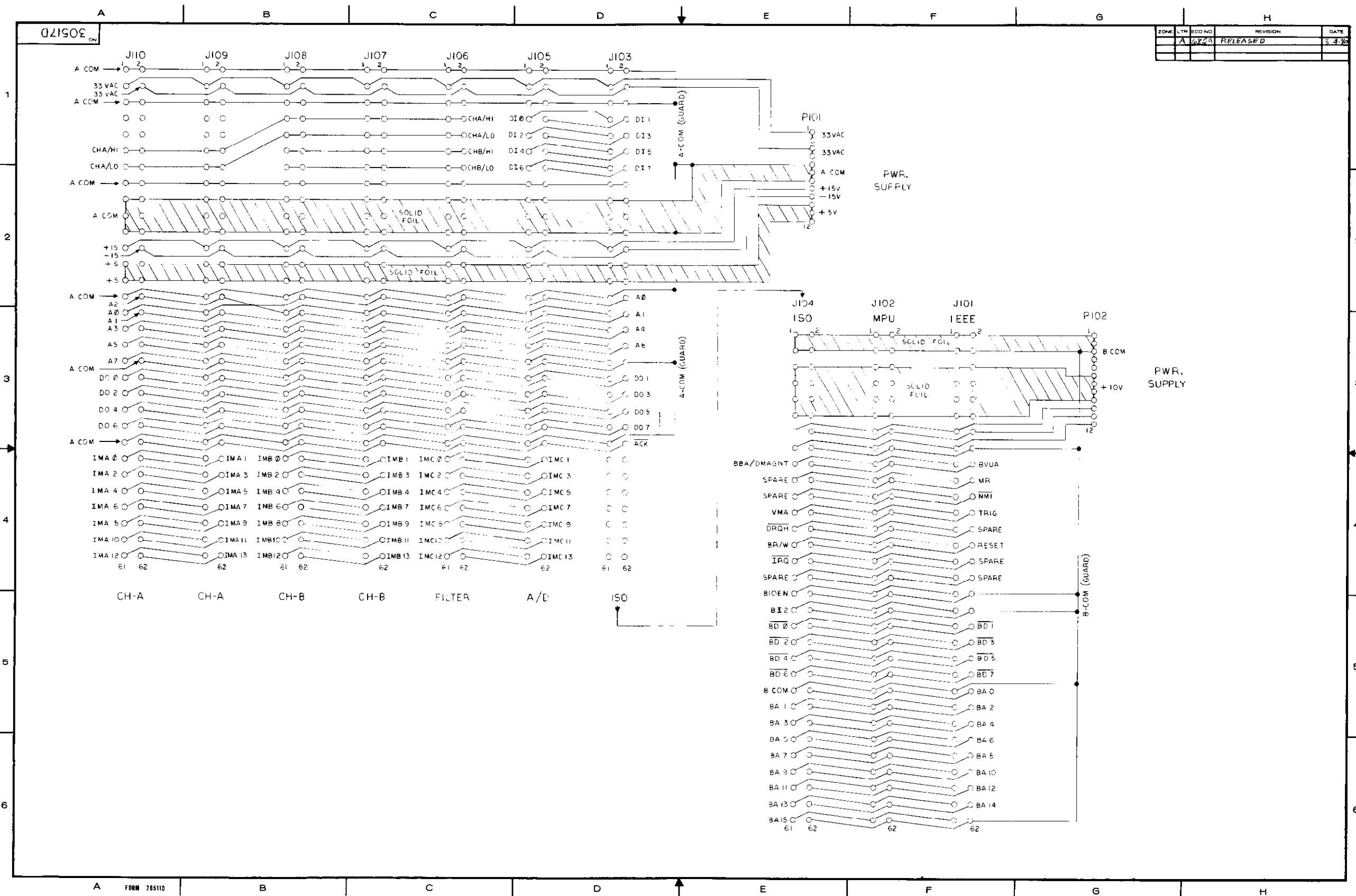

ZONE	LTR	ECO NO	REVISION	DATE
A	10720		RELEASED	5.4.82

A FORM 28511D

Figure 7-10. Mother Board, Schematic Diagram, Dwg. No. 30517

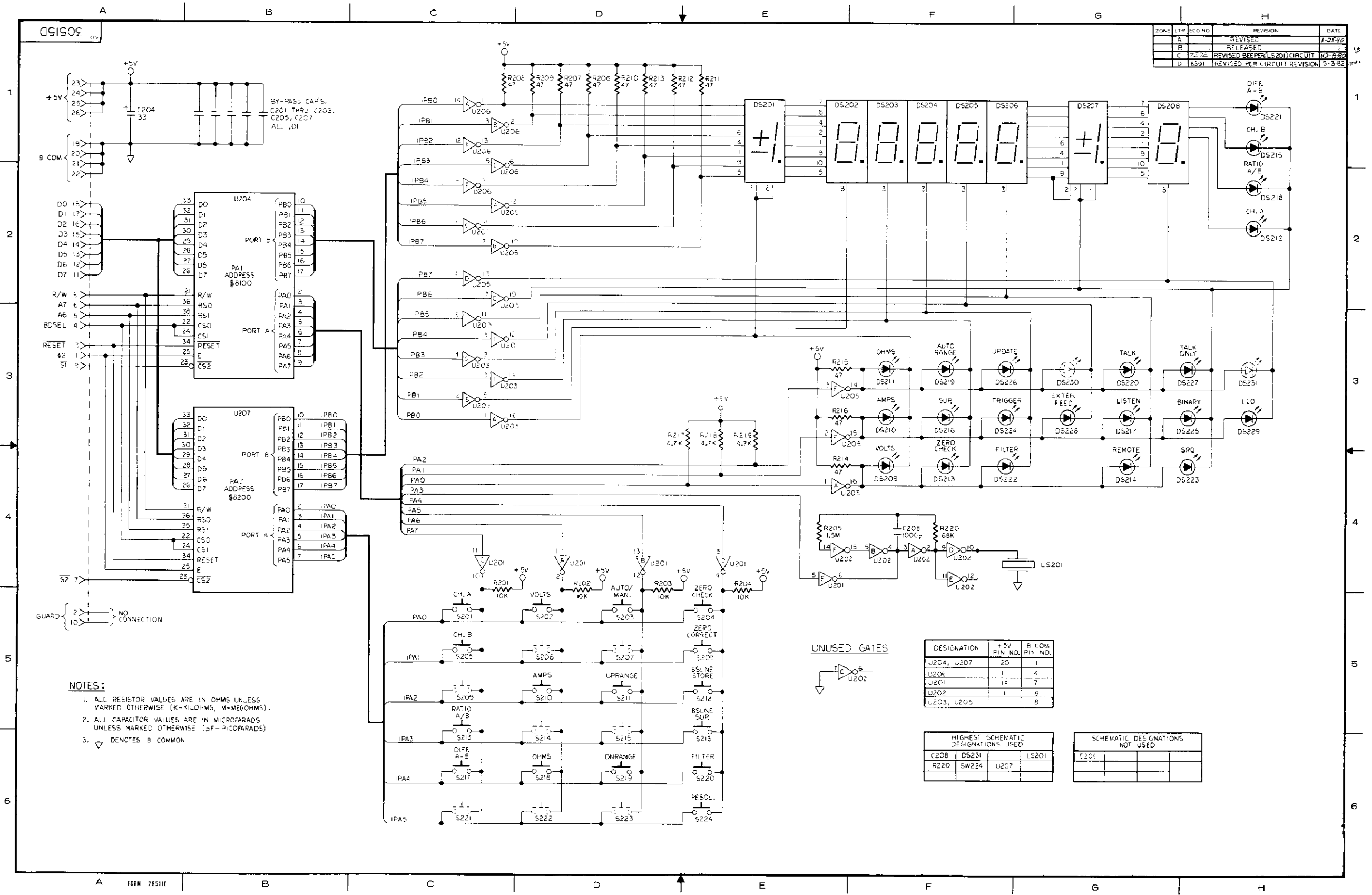

**NOTES:**

1. ALL RESISTOR VALUES ARE IN OHMS UNLESS MARKED OTHERWISE (K-KILOHMS, M-MEGOHMS).
2. ALL CAPACITOR VALUES ARE IN MICROFARADS UNLESS MARKED OTHERWISE (PF-PICOPARADS)
3. ∇ DENOTES B COMMON

UNUSED GATES

DESIGNATION	+5V PIN NO.	B COM PIN NO.
U204, U207	20	1
U206	11	4
U201	14	7
U202	1	8
U203, U205	1	8

HIGHEST SCHEMATIC DESIGNATIONS USED			
C208	DS231	LS201	
R220	SW224	U207	

SCHEMATIC DESIGNATIONS NOT USED			
C204			

Figure 7-11. Display Board PC-514, Schematic Diagram, Dwg. No. 30515

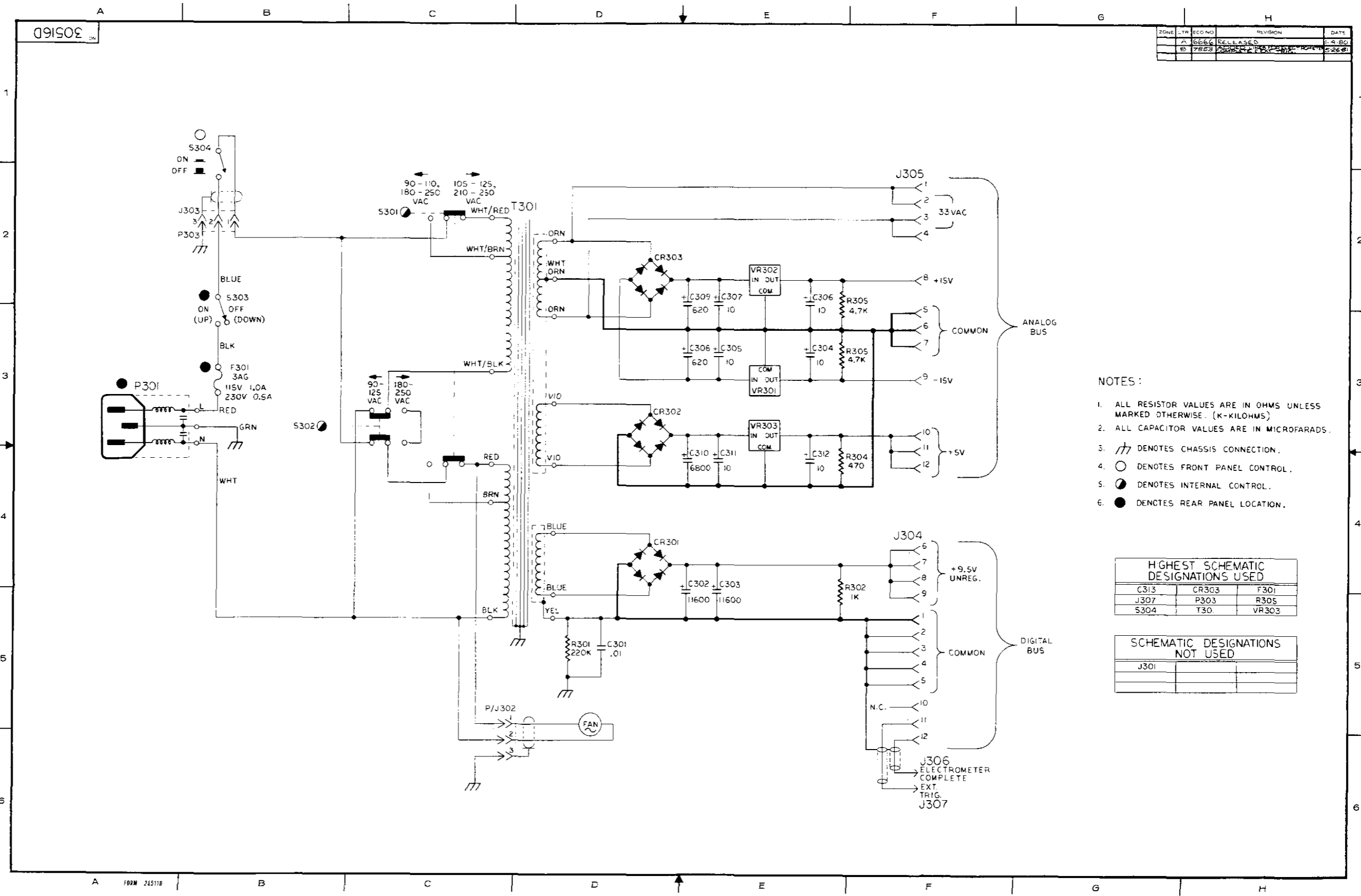

Figure 7-12. Power Supply, Schematic Diagram, Dwg. No. 30516

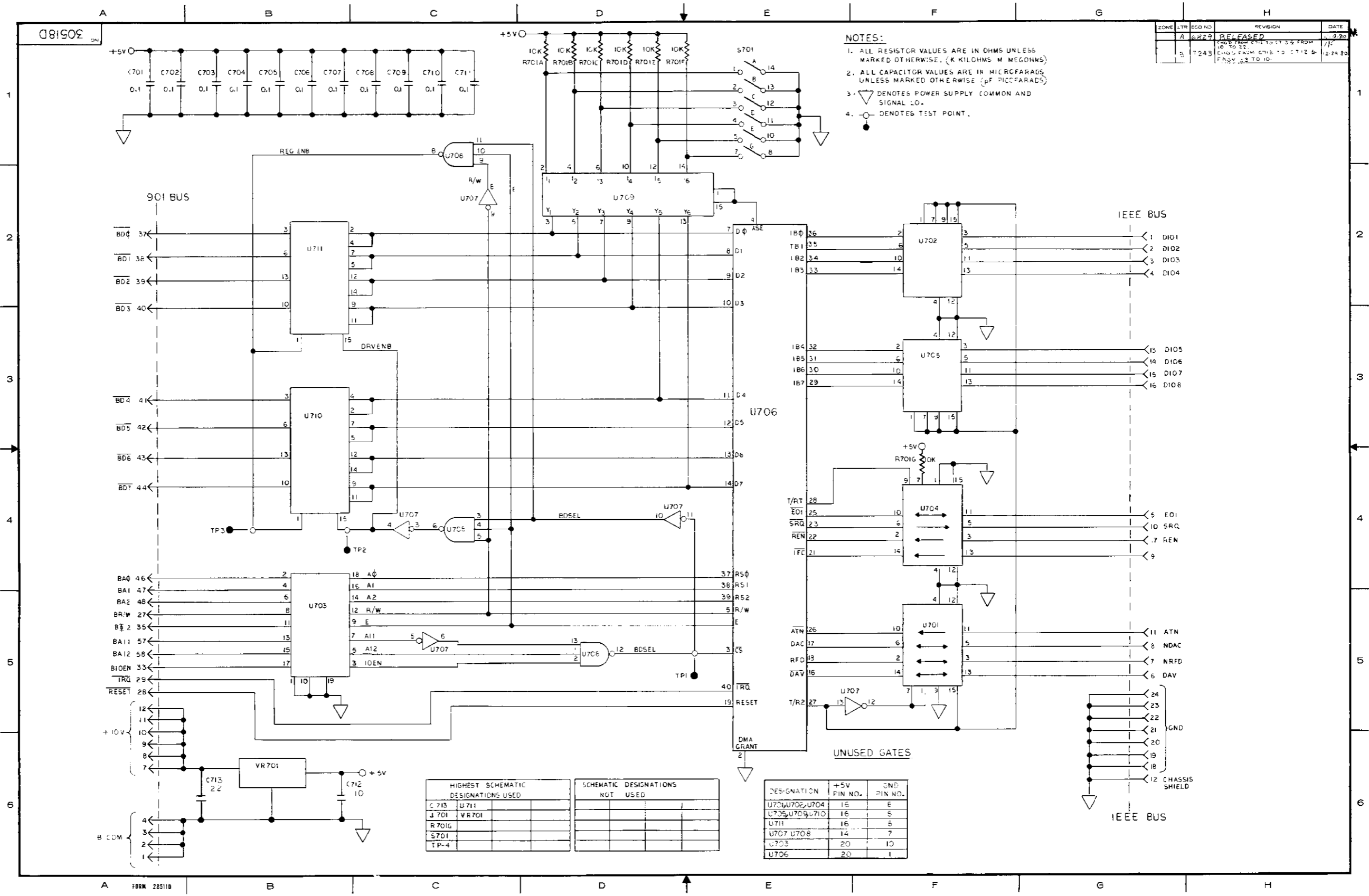
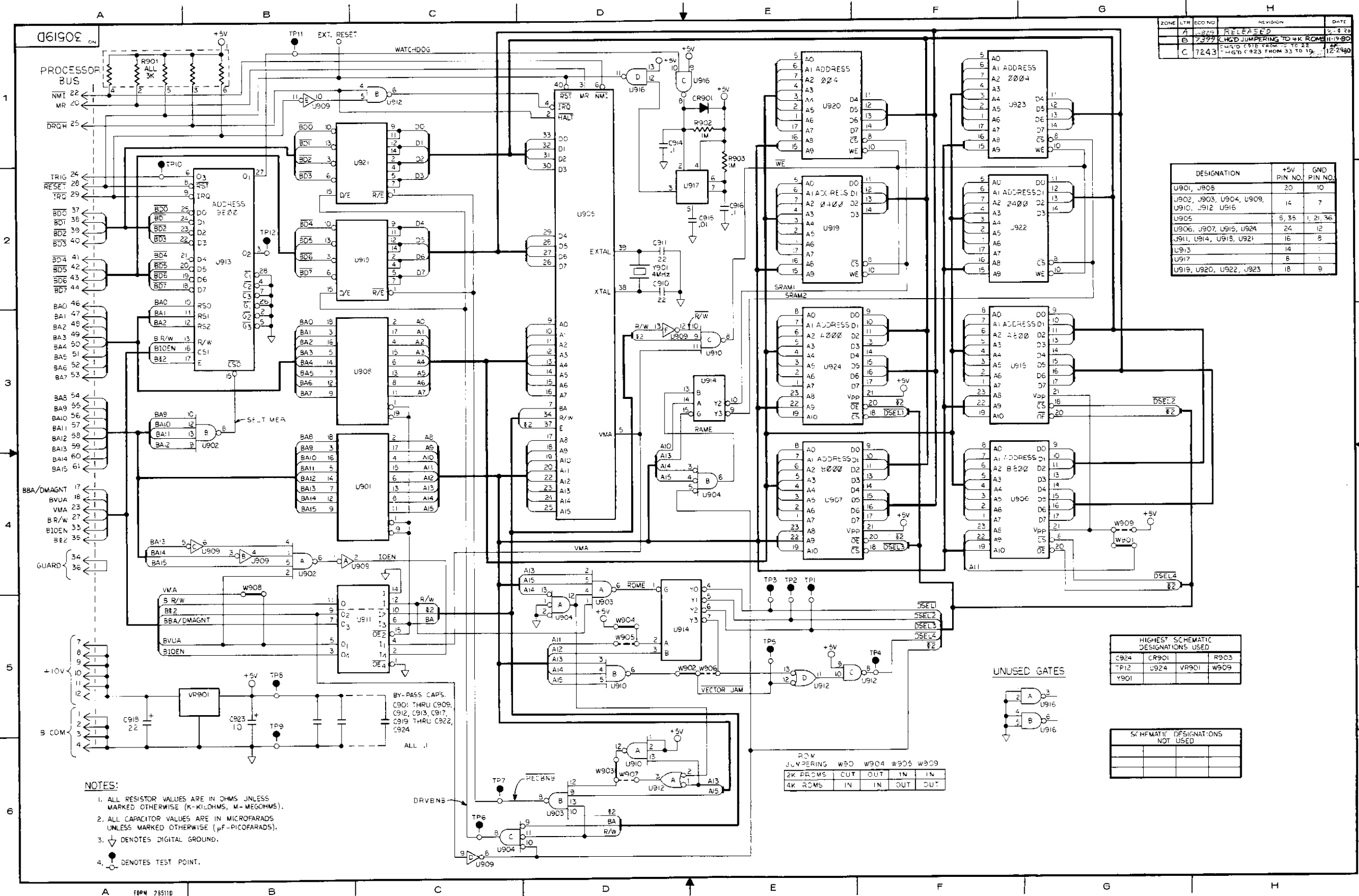

Figure 7-13. IEEE Interface PC-517, Schematic Digaram, Dwg. No. 30518





ZONE	LTR	ECO NO.	REVISION	DATE
A		1	RELEASED	5-8-80
B		2	CHG JUMPERING TO 4K ROMS	11-19-80
C		3	CHG TRIS FROM 15 TO 23 +GND C 923 FROM 33 TO 19	12-24-80

DESIGNATION	+5V PIN NO.	GND PIN NO.
U901, U908	20	10
J902, J903, U904, U909, U910, U912, U916	14	7
U905	8, 35	1, 21, 36
U906, U907, U915, U924	24	12
J911, U914, U915, U921	16	8
U913	14	1
U917	6	1
U919, U920, U922, U923	18	9

HIGHEST SCHEMATIC DESIGNATIONS USED		
C924	U901	R903
TP12	U924	VR901
Y901		W909

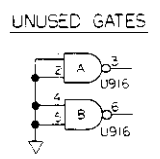

SCHEMATIC DESIGNATIONS NOT USED			

ROW	JUMPERING	W90	W904	W905	W909
2K ROMS	CUT	OUT	IN	IN	
4K ROMS	IN	IN	OUT	OUT	

- NOTES:
1. ALL RESISTOR VALUES ARE IN OHMS UNLESS MARKED OTHERWISE (K-KILOHMS, M-MEGOHMS).
  2. ALL CAPACITOR VALUES ARE IN MICROFARADS UNLESS MARKED OTHERWISE (pF-PICOFARADS).
  3. ↓ DENOTES DIGITAL GROUND.
  4. ● DENOTES TEST POINT.

Figure 7-14. Processor (CPU) Board PC-518, Schematic Diagram Dwg. No. 30519

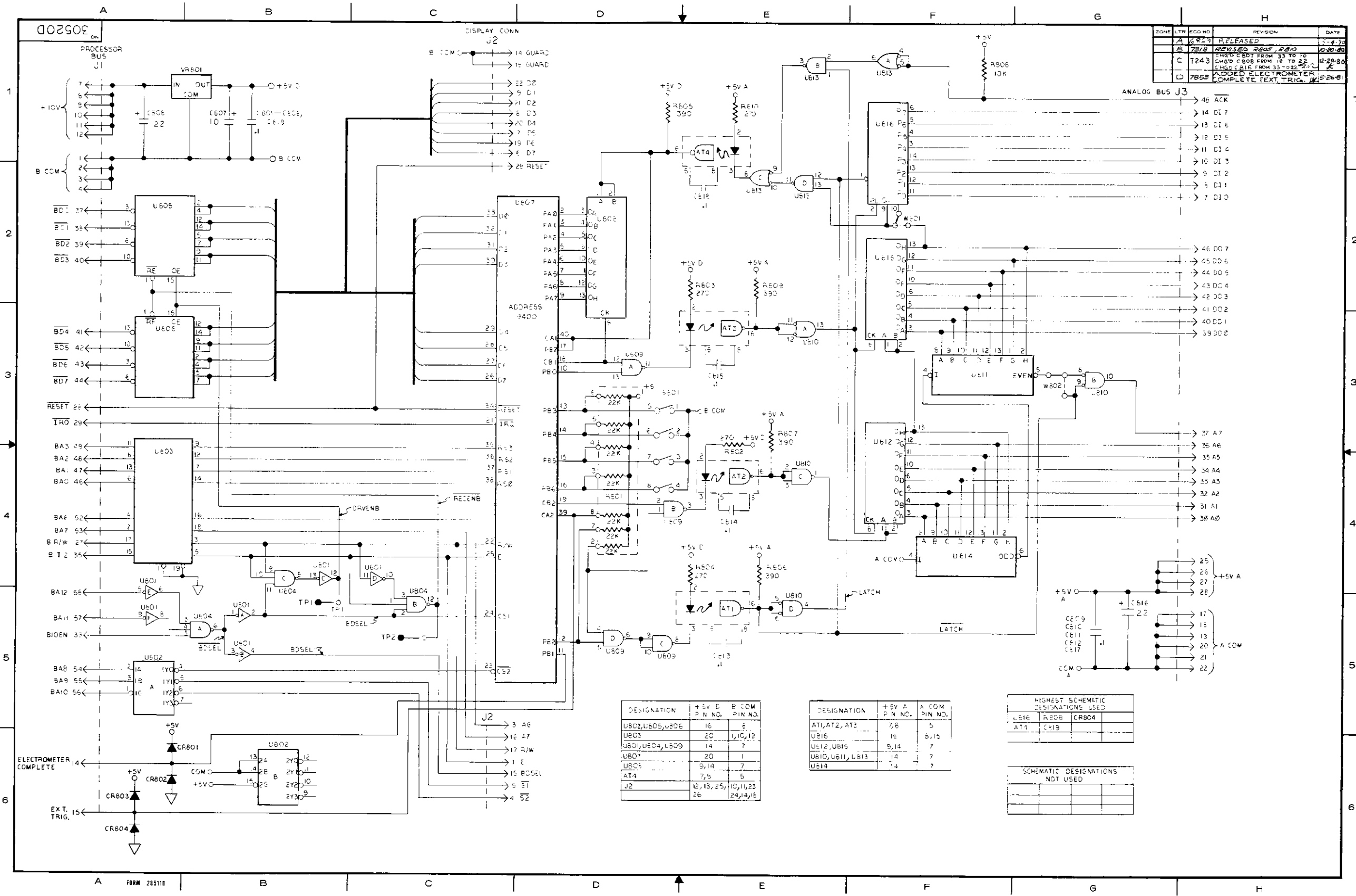
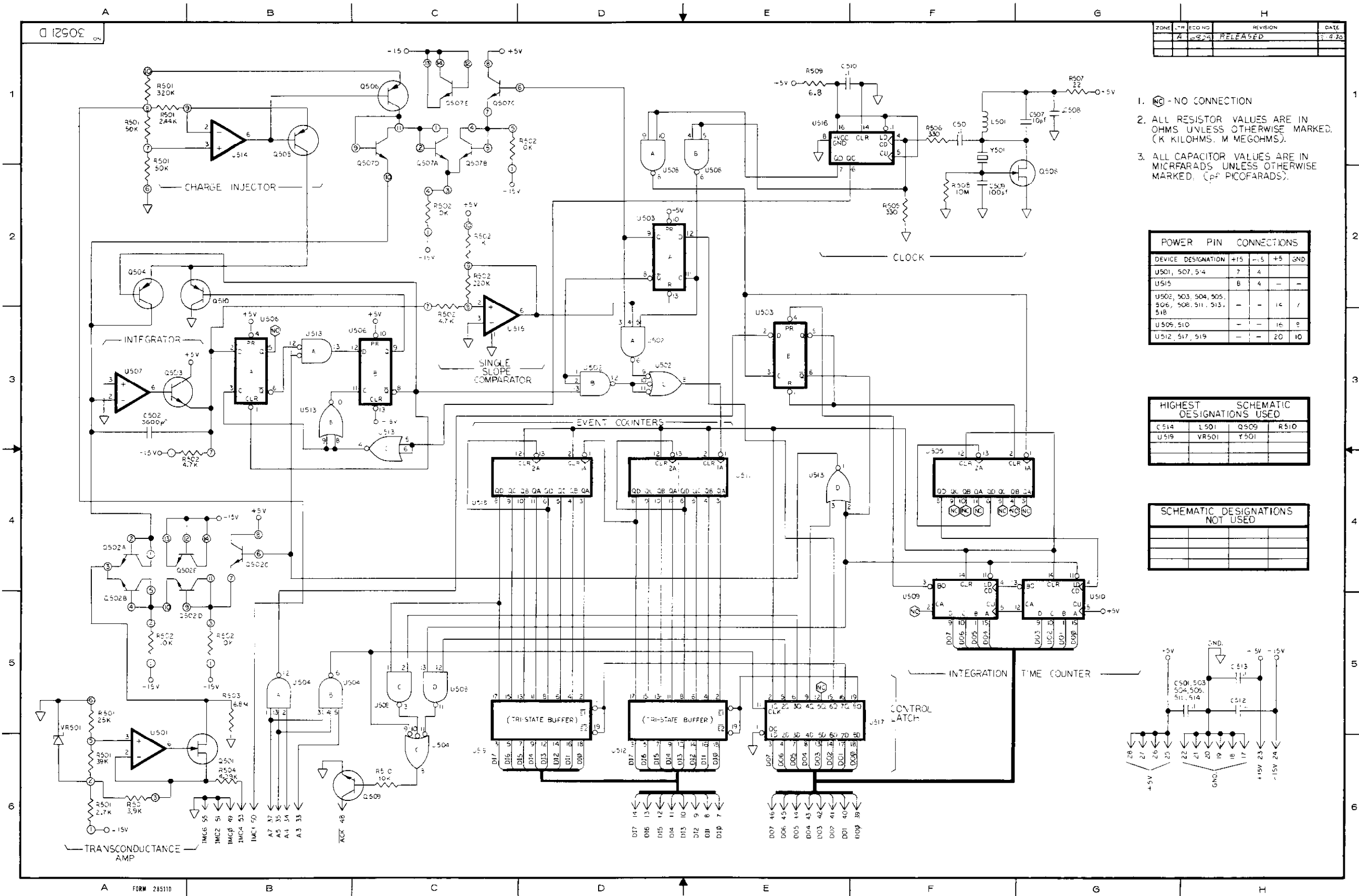

Figure 7-15. Isolator Board PC-519, Schematic Diagram, Dwg. No. 30520



ZONE	REV	REASON	REVISION	DATE
A	1	RELEASED		3-8-60

1. (NC) - NO CONNECTION
2. ALL RESISTOR VALUES ARE IN OHMS UNLESS OTHERWISE MARKED. (K KILOHMS, M MEGOHMS).
3. ALL CAPACITOR VALUES ARE IN MICROFARADS UNLESS OTHERWISE MARKED. (PF PICOFARADS).

POWER PIN CONNECTIONS				
DEVICE DESIGNATION	+15	-5	+5	GND
U501, 507, 514	7	4		
U515	B	4		
U502, 503, 504, 505, 506, 508, 511, 513, 518			14	1
U509, 510			16	8
U512, 517, 519			20	10

HIGHEST SCHEMATIC DESIGNATIONS USED			
C 514	L 501	Q 509	R 510
U 519	VR 501	Y 501	

SCHEMATIC DESIGNATIONS NOT USED			

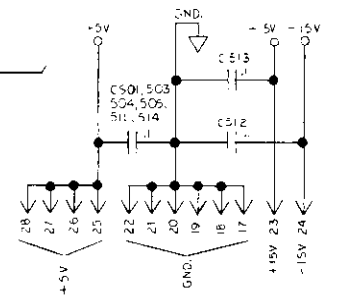

Figure 7-16. A/D Converter PC-520, Schematic Diagram, Dwg. No. 30521

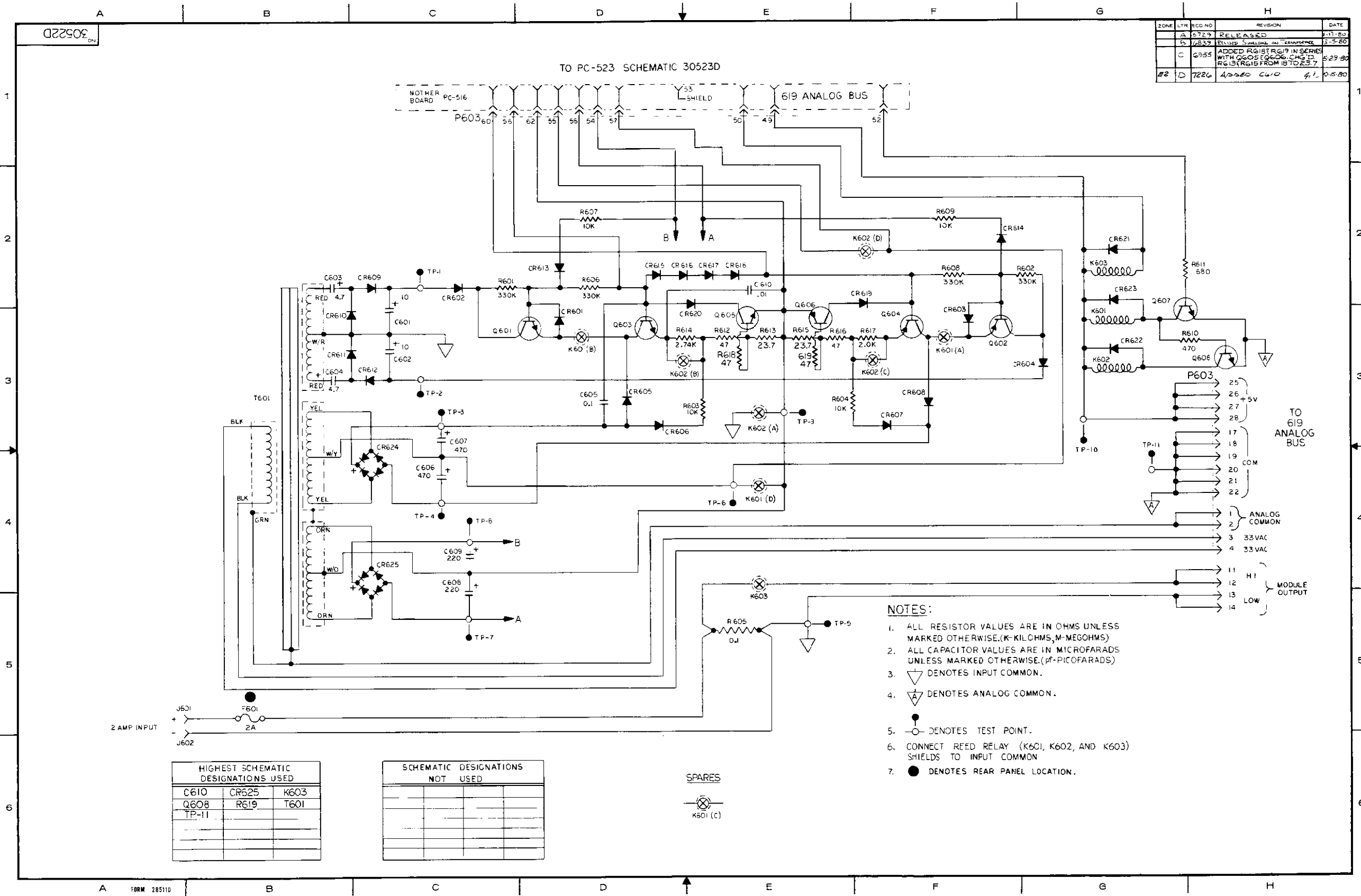
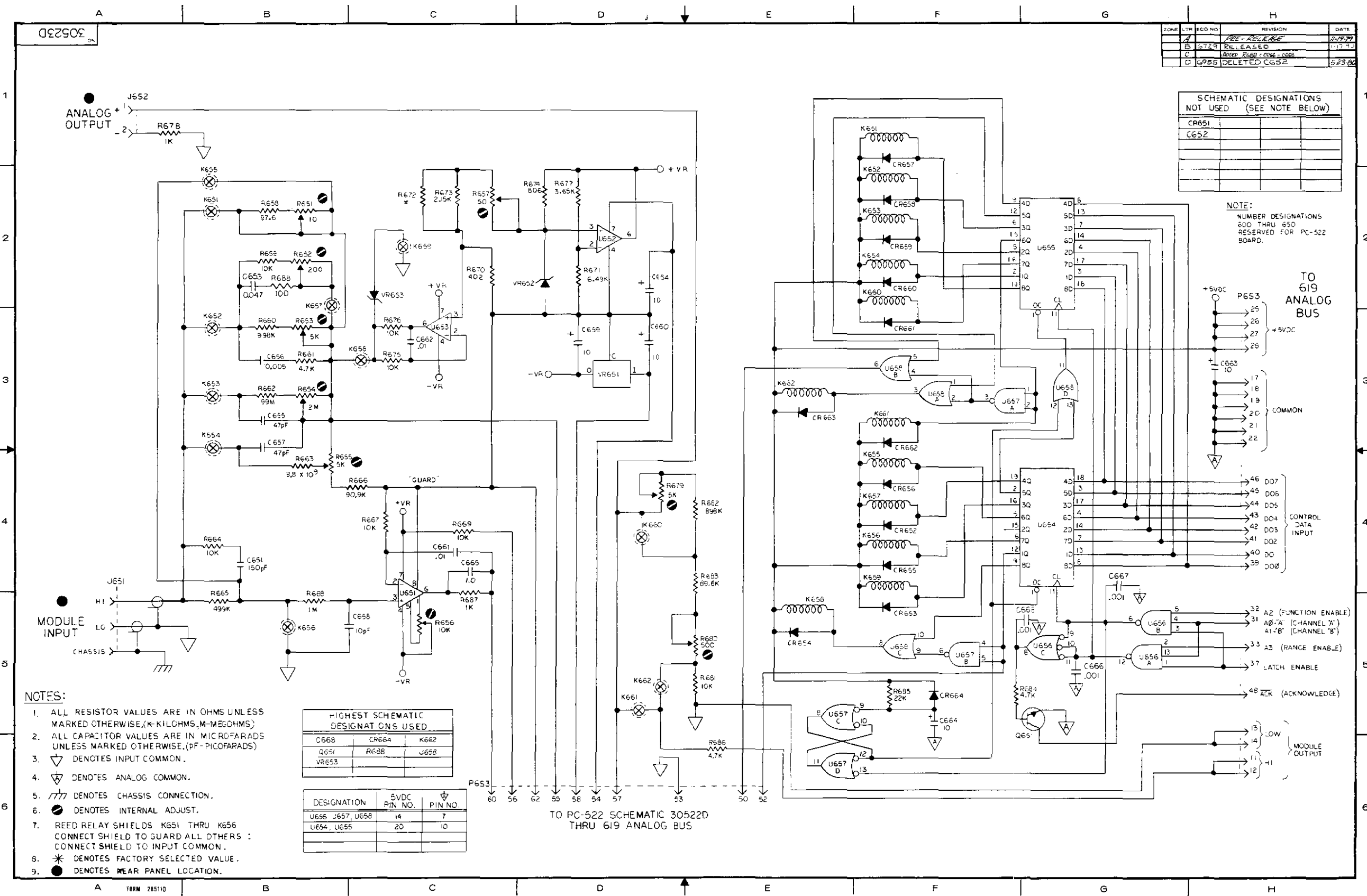

Figure 7-17. Electrometer Module PC-522, Schematic Diagram, Dwg. No. 30522

20K - 20.1K



ZONE	LTR	ECO NO.	REVISION	DATE
A			PRE-RELEASE	1-17-70
B	5723		RELEASED	1-17-70
C			REWORK 2000 - 2000 - 0000	
D	4955		DELETED CG52	5-23-80

SCHEMATIC DESIGNATIONS NOT USED (SEE NOTE BELOW)			
CR651			
CG52			

NOTE:  
NUMBER DESIGNATIONS 600 THRU 650 RESERVED FOR PC-522 BOARD.

- NOTES:**
- ALL RESISTOR VALUES ARE IN OHMS UNLESS MARKED OTHERWISE (K-KILOHMS, M-MEGOHMS)
  - ALL CAPACITOR VALUES ARE IN MICROFARADS UNLESS MARKED OTHERWISE (PF-PICOFARADS)
  - ∇ DENOTES INPUT COMMON.
  - ▽ DENOTES ANALOG COMMON.
  - ⏏ DENOTES CHASSIS CONNECTION.
  - ⊗ DENOTES INTERNAL ADJUST.
  - REED RELAY SHIELDS K651 THRU K656 CONNECT SHIELD TO GUARD ALL OTHERS: CONNECT SHIELD TO INPUT COMMON.
  - \* DENOTES FACTORY SELECTED VALUE.
  - DENOTES REAR PANEL LOCATION.

HIGHEST SCHEMATIC DESIGNATIONS USED		
C668	CR664	K662
Q651	R688	J658
VR653		

DESIGNATION	5VDC PIN NO.	PIN NO.
U656, J657, U658	14	7
U654, U655	20	10

TO PC-522 SCHEMATIC 30522D THRU 619 ANALOG BUS

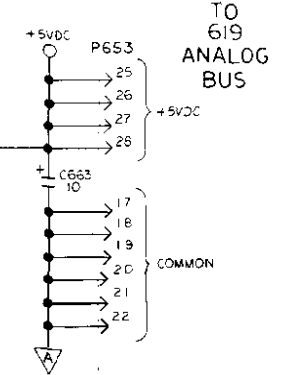

Figure 7-17. Electrometer Module PC-523, Schematic Diagram, Dwg. No. 30523

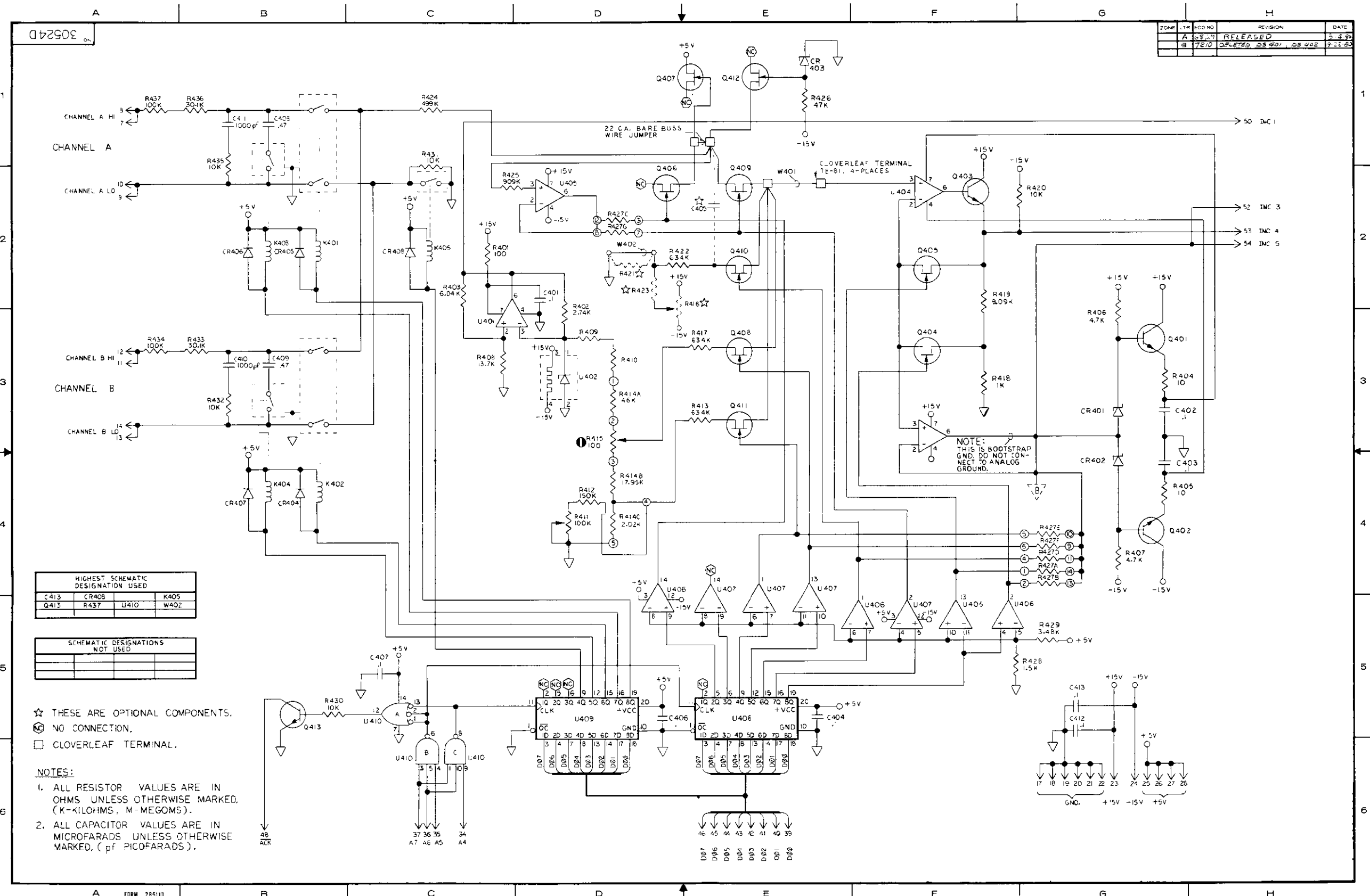

Figure 7-18. Filter Mux Board PC-521, Schematic Diagram, Dwg. No. 30524



# SERVICE FORM

Model No. \_\_\_\_\_ Serial No. \_\_\_\_\_ P.O. No. \_\_\_\_\_ Date \_\_\_\_\_

Name \_\_\_\_\_ Phone \_\_\_\_\_

Company \_\_\_\_\_

Address \_\_\_\_\_

City \_\_\_\_\_ State \_\_\_\_\_ Zip \_\_\_\_\_

List all control settings and describe problem. \_\_\_\_\_  
\_\_\_\_\_  
\_\_\_\_\_

(Attach additional sheets as necessary.)

Show a block diagram of your measurement system including all instruments connected (whether power is turned on or not). Also describe signal source.

Where is the measurement being performed? (factory, controlled laboratory, out-of-doors, etc.) \_\_\_\_\_

What power line voltage is used? \_\_\_\_\_ Variation? \_\_\_\_\_

Frequency? \_\_\_\_\_ Ambient Temperature? \_\_\_\_\_ °F.

Variation? \_\_\_\_\_ °F. Rel. Humidity? \_\_\_\_\_ Other? \_\_\_\_\_

Any additional information. (If special modifications have been made by the user, please describe below.)

\_\_\_\_\_  
\_\_\_\_\_

\*Be sure to include your name and phone number on this service form.