

# PRECISION DC POWER SOURCE

TECHNICAL DATA

MODEL 2005



POWER DESIGNS

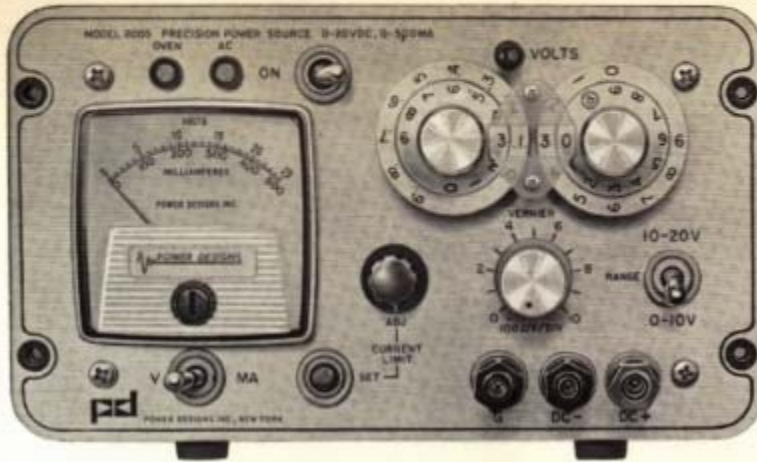

0-20 V, 0-500 MA  
A general purpose  
power supply  
with the accuracy  
of a precision  
calibrator



Pair of Model 2005 Units shown in Type RRB-12 Rack Panel Adapter.

PRICE  
**\$325.00**  
FOB Westbury

PRINTED IN U.S.A.

**POWER DESIGNS, INC.**  
1700 SHAMES DRIVE • WESTBURY, N.Y.  
516 EDGWOOD 3-5200 TWX; 510-222-6861

**POWER DESIGNS PACIFIC, INC.**  
3281 JUNIPERO SERRA • PALO ALTO, CALIFORNIA  
415-321-6111 TWX; 910-373-1251

**POWER DESIGNS, INC. | POWER DESIGNS PACIFIC, INC.**

SERIAL NUMBER 204246

<p>Description</p> <p>New high-stability, low-noise silicon semiconductor devices and advanced solid-state circuit technology are the basis for this unusually stable voltage regulator. The improved performance of the Model 2005 permits dial readout of the output voltage to five places. Interpolation of the last place is provided by a potentiometer with a resolution of 10 microvolts. Conventional, more complex chopper techniques for DC amplifier stabilization are avoided by maintaining critical amplifier stages and a specially processed zener diode voltage reference in a temperature-controlled oven. The design simplicity results in a low-cost unit, half the size and weight of comparable instrumentation.</p> <p>Design Features of the Model 2005</p> <ul style="list-style-type: none"> <li>• Calibrated decade voltage readout to four significant figures at outputs below 10 volts, to five significant figures above 10 volts. Interpolation of the last place is provided by a potentiometer with 10-microvolts resolution.</li> <li>• Provisions for rear-panel zero calibration (may be used to offset lead drop during remote sensing).</li> <li>• Adjustable current limiting.</li> </ul>	<ul style="list-style-type: none"> <li>• Self-restoring electronic overload and short-circuit protection.</li> <li>• All silicon-semiconductor regulator system.</li> <li>• Critical semiconductors and components maintained at constant ambient in temperature-controlled oven.</li> <li>• Accurate remote programming at 1000 ohms-per.volt.</li> <li>• Front and rear access to output terminals.</li> <li>• 100 hour pre-aging of power supply before test and calibration. Individual calibration data furnished with each unit.</li> <li>• Line and load circuits separately fused. Accessible at rear. Performance specifications based on anticipated ratings after 5 years service.</li> <li>• "Controlled-Parameter" semiconductor program insures long life expectancy. Features "controlled avalanche" silicon rectifiers and power transistors, pre-aged zener voltage references and transistors, noise-testing techniques for establishing predictable device reliability, derating to 50% of rated voltage and current, etc.</li> <li>• Modular package construction suitable for rack mounting. Single or dual mounting in 5¼"x 19" panel. See Cat. RPA-62 for rack panel adapters.</li> </ul>
--	--

## General Description

- **OUTPUT** - 0 to 20 VDC, continuously adjustable, at 0 to 500 MA.
- **INPUT** - 105 to 125 V, 50 to 440 Hz, 40 W max. (Including oven heater).
- **CALIBRATION AND ACCURACY** - Two dual, concentric, decade switches provide dial readout to four places with an accuracy of  $0.1\% \pm 1 \text{ MV}$  at outputs below 10 V. A 1-MV range, single-turn potentiometer permits interpolation of the last place. This potentiometer has a resolution of 10 uV. A toggle switch extends the range of the dial readout from 10 to 20 V, without affecting resolution or accuracy (five-place readout). An illuminated indicator identifies the range in operation.
- **REGULATION** - Output voltage change less than 100 uV (at sense connection points) for line or load variations over the operating range.
- **RIPPLE AND NOISE** - Less than 100 uV peak-to-peak.
- **SOURCE IMPEDANCE** - Less than 0.2 milliohm at DC, 0.04 ohm at 20 KHz, 0.5 ohm at 1 MHz.
- **RECOVERY TIME** - Less than 10 uS to return to within 250 uV or 0.005% (whichever is greater) of the set voltage for a 10% to 100% step change in rated load; less than 40 uS to return with 100 uV.
- **OPERATING TEMPERATURE RANGE** - 15 to 4 °C ambient; 0 to 60 °C ambient with reduced accuracy.
- **TEMPERATURE COEFFICIENT** - DC output voltage change less than 0.001% or 50 uV (whichever is greater) per °C over the range of +15 to +45°C; less than 0.002% or 100uV (whichever is greater) per °C from 0 to +15°C and +45 to +60 °C.

- **STABILITY** - Better than 0.001% + 100 MV/8 hrs.; better than 1 MV/wk (at constant ambient temperature, load and line voltage, after warmup).
- **OUTPUT TERMINALS** - Three front-panel binding posts and rear-panel barrier block. Either positive or negative output terminal may be grounded.
- **METER** - Front-panel volt-ammeter permits monitoring output voltage or current with an accuracy of  $\pm 2\%$ .
- **REMOTE SENSING** - Two terminals on rear-panel barrier block are provided for remote sensing of voltage at the load.
- **REMOTE PROGRAMMING** - Rear terminals are provided for remote programming of the output voltage at 1000 ohms-per-volt. Accuracy of programming is better than 0.01% of value of resistance (including connecting leads).
- **CURRENT LIMITING** - The output current can be limited to any value from 0 to 500 MA by a front-panel control. A push-button permits easy adjustment without the need for shorting the output terminals.

# SECTION 1

## GENERAL DESCRIPTION

### 1-1. DESCRIPTION

The Model 2005 is a precision DC power source designed to supply an extremely stable 0 to 20 volt, 0 to 500 milliampere output. The instrument combines the accuracy of a precision calibrator with the power capability of a general-purpose regulated supply. Two dual, concentric decade switches provide a digital readout of the selected output voltage to within 0.1% +1 millivolt of the selected value. A 1-millivolt range, single-turn potentiometer permits interpolation of the last place. This potentiometer has a resolution of 10 microvolts. A toggle switch selects the range of the dial readout; either from 0 to 10 volts, or from 10 to 20 volts. The output voltage of the supply may be remotely programmed with the same accuracy, using an external resistance. The supply also includes provisions for remote sensing of the output voltage at the load. Compact and light, the power source is self-contained in a portable housing designed for bench use. The modular construction of the Model 2005 makes it suitable for rack mounting. Panel adapters are available for mounting one or two units in a standard 19-inch rack having a panel height of 5 1/4 inches.

### 1-2. ELECTRICAL SPECIFICATIONS

Refer to Table 1 for a complete list of electrical specifications.

<b>TABLE 1. ELECTRICAL SPECIFICATIONS</b>	
Parameter	Value
Output	0 to 20 volts DC, continuously adjustable, 0 to 500 milliamperes
Input	105 to 125 volts, 50 to 440 Hz, 40 watts (nominal) Regulation DC voltage change less than 100 microvolts for line variations of $\pm 10\%$ or load variations of 100% (at sense lead connection points)
Ripple and Noise	Less than 100 microvolts peak-to-peak
Source Impedance	Less than 0.2 milliohm at DC, 0.04 ohm at 20 KHz, 0.5 ohm at 1 MHz
Recovery Time	Less than 10 microseconds to return to within 250 microvolts or 0.005% (whichever is greater) of the set voltage for a step change in rated load (1 microsecond rise time) of 10% to 100% or 100% to 10%; less than 40 microseconds to return to within 100 microvolts
Stability	Better than 0.001% +100 microvolts per 8 hours; better than 1 millivolt per week (at constant line, load and ambient temperature after warm-up).
Temperature Coefficient	DC output voltage change less than 0.001% or 50 microvolts (whichever is greater) per $^{\circ}\text{C}$ over the range of $+15^{\circ}\text{C}$ to $+45^{\circ}\text{C}$ , less than 0.002% or 100 microvolts (whichever is greater) per $^{\circ}\text{C}$ from $^{\circ}\text{C}$ from $0^{\circ}\text{C}$ to $+15^{\circ}\text{C}$ and from $+45^{\circ}\text{C}$ to $+60^{\circ}\text{C}$
Calibration Accuracy	Better than 0.1% +1 millivolt
Current Limiting	0 to 500 milliamperes continuously adjustable by a front panel control. A front panel push button permits easy adjustment without shorting the output terminals.

Output Terminals	
Front Panel	Three insulated binding posts for positive output, negative output, and chassis ground
Rear Panel	Screw terminals on a molded barrier block for positive output, negative output, chassis ground, remote voltage programming and remote sensing.
Remote Sensing	Two terminals are provided on a rear panel barrier block for remote sensing of the voltage at the load.
Parameter	Specifications
Remote Programming	Rear panel barrier block terminals are provided for remote programming of the output voltage. The ratio of the programming resistance to the output voltage is 1000 ohms per volt. The programming accuracy is better than 0.01% of the resistance value, including the resistance of the programming leads.
Metering	Front panel volt-ammeter permits monitoring output voltage or current with an accuracy of $\pm 2\%$ of full scale. NOTE: This accuracy is considerably less than that of the power source.
Circuit Protection	The AC line and DC load circuits are separately fused. The fuses are accessible at the rear of the unit.
Indicator Lamps	
AC Lamp	Lights when AC toggle switch is set to ON and power is applied to the unit.
OVEN Lamp	Lights when AC input is applied and oven heater is energized (operates even when AC toggle switch is turned off). Lamp cycles on and off as oven maintains constant temperature environment for critical components.
+10 V Lamp	Lights when RANGE switch is set to 10-20V position to indicate that output is 10 volts plus the dial readout.

### 1-3. MECHANICAL SPECIFICATIONS

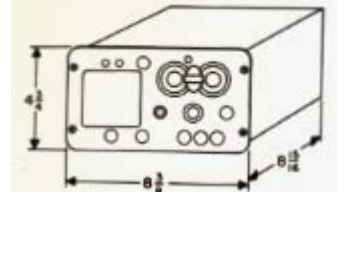
	<ul style="list-style-type: none"> <li>• Dimensions : 8-3/8 inches wide by 4-3/4 inches high by 8-15/16 inches deep behind the front panel.</li> <li>• Weight : 9 pounds.</li> <li>• Finish : The panel is finished in brushed aluminum and has etched black lettering. The housing is finished in blue-gray vinyl enamel. The chassis and bottom plate are gold iridite.</li> </ul>
---	--

# SECTION 2

## 2) INSTALLATION AND OPERATION

### 2-1 INSTALLATION

- a) Laboratory Bench . The Model 2005 is a portable unit designed for bench use. No preliminary processing or special unpacking procedures are required. The power source is ready for operation as shipped from the factory.
- b) Rack Mounting . Panel adapters are available for mounting one or two units in a standard 19-inch relay rack. Hardware kits are provided with each panel adapter. The power source is fastened to the rear surface of the adapter with the black anodized rivnuts in each corner of its front panel. If the rubber bumper feet interfere with the assembly of the equipment to the rack, they may be removed by disassembling the bottom plate of the power source and unscrewing them.

### 2-2 OPERATION

- a) Operating Procedures:
  - (i) Ensure that the power source is turned off and the shorting links are connected between the following rear-panel terminals: DC+ and S+; S+ and RV; and S- and DC-.
  - (ii) Set the CURRENT LIMIT ADJ control fully clockwise.
  - (iii) Connect the AC line cord to a source of 105 to 125 volts, 50 to 440 Hz. NOTE: The OVEN indicator will normally light as soon as line voltage is applied to the unit, even when the power source is turned off. The indicator will remain lighted until the oven reaches operating temperature (approximately 10 minutes). The indicator will cycle on and off as the oven maintains a constant- temperature environment for critical circuit components.
  - (iv) Read the information in paragraphs b through e to connect for remote sensing, series operation, remote programming of the output voltage, or current limiting.
  - (v) Set the AC switch to ON.
  - (vi) Set the output voltage to the desired value, using the front panel dials. Set the VERNIER control to zero if interpolation between 1 millivolt steps is not desired.
  - (vii) Connect the DC+ and DC- terminals (on the front or rear panel) across the load. If desired, connect the positive or negative output terminal to ground.
- b) Sensing: The regulator circuit maintains the potential between the sense leads (s+ and S-) at the set output voltage. When these leads are connected to the positive and negative output terminals, the power source is connected for local sensing. When the sense leads are connected to the load, the source is connected for remote sensing. Remote sensing is used when an appreciable voltage drop is anticipated in the leads connecting the positive and negative output terminals to the load. The Model 2005 is connected for local sensing when shipped from the factory. For remote sensing, proceed as follows:
  - (i) Remove the shorting links from between the rear panel DC+ and S+ terminals and from between the DC- and S- terminals.
  - (ii) Connect the DC+ and DC- leads across the load.
  - (iii) Connect the S+ and S- leads to the positive and negative sides of the load, respectively. Run the sense leads as a tightly twisted, shielded pair. Connect the shield to the G (chassis ground) terminal to minimize output ripple
  - (iv) Turn on the Model 2005.

- c) **Series Operation:** As many as four Model 2005 units may be connected in series to provide up to 80 volts. Connect the positive DC output terminal of one supply to the negative output terminal of the next, in the same manner as connecting batteries in series. The ground terminals on all units may be left floating or they may be tied together and connected to either the most positive or the most negative output terminal. To insure optimum voltage regulation, disconnect the shorting links between all S+ and DC+ output terminals except those at the most positive potential. Then connect jumper wires between each S+ terminal and the S- terminal on the next more positive power source. In this way, the voltage drops in the leads connecting the power sources will be compensated for by the regulator circuits of the individual units. For remote sensing, proceed as directed above, except connect the most positive and most negative S+ and S- leads across the load.
- d) **Remote Voltage Programming:** The output voltage can be programmed remotely by an external fixed or variable resistance. Proceed as follows:
- (i) Turn off the power source, set all output voltage controls to zero and set the RANGE switch to 0 -10V.
  - (ii) Remove the shorting link from between the rear panel RV and S+ terminals.
  - (iii) Select a programming resistance by multiplying the desired output voltage by 1000 (the programming constant is 1000 ohms per volt). A constant current of 1 milliamperes will flow through this resistance, and its wattage rating should be chosen to minimize drift due to heating.
  - (iv) Connect the external programming resistance between the RV and S+ terminals using twisted, shielded wire. Connect the shield to the G (chassis ground) terminal to minimize output ripple.
  - (v) Turn on the power source.
- CAUTION: IF THE REMOTE PROGRAMMING CONNECTIONS ARE OPENED WHILE THE SUPPLY IS OPERATING, THE OUTPUT VOLTAGE WILL RISE SLIGHTLY ABOVE THE SET VALUE. WHEN A SWITCH IS USED TO SELECT RESISTORS FOR OUTPUT VOLTAGE PROGRAMMING, IT SHOULD HAVE SHORTING TYPE CONTACTS TO AVOID VOLTAGE SPINES.**
- e) **Current Limiting:** The maximum output may be limited to a value below 500 milliamperes as follows:
- (i) Turn on the power source and set the meter switch to MA.
  - (ii) Depress the CURRENT LIMIT SET button and adjust the CURRENT LIMIT ADJ control until the meter indicates the maximum desired output current. Release the CURRENT LIMIT SET button.

# SECTION 3

## 3) PRINCIPLES OF OPERATION

### 3-1 GENERAL

The Model 2005 is a highly accurate, series regulated, DC voltage source. Basically, it consists of a full-wave rectifier circuit, a series regulator circuit and a current limiting circuit.

The series regulator circuit is essentially an electronically variable resistance interposed between the unregulated source and the load. The resistance value is controlled by an amplifier that compares the source output voltage with a reference voltage. The amplifier adjusts the series resistance to reduce the error signal to zero.

The reference voltage is generated by an internal auxiliary power source. The error signal resulting from the voltage comparison is amplified and applied through a driver stage to the series transistor to vary its effective resistance.

### 3-2 FULL-WAVE RECTIFIER OPERATION

The full-wave rectifier consists of diodes CR1 and CR2. Its output is applied through fuse F2 to series regulator transistor Q1. The output of the full-wave rectifier is filtered by capacitor C1.

### 3-3 SERIES REGULATOR OPERATION

The series regulator circuit consists of differential amplifier Q5, amplifiers Q4, Q6 and Q7; driver Q2 and series regulator Q1. The voltage reference for the differential amplifier is zener diode CR13. A constant current is maintained through CR13 by transistors Q9 and Q10 and zener diode CR11. These components are powered by an auxiliary 20-volt supply.

The constant voltage across CR13 is impressed across the base-emitter junction of one-half of Q5. Potentiometer R12 is adjusted to bias the base-emitter junction of the input half of Q5 to the same potential. Zener diode CR10 provides a constant collector voltage for the input section of the differential amplifier. A constant current for this zener diode is provided by CR22 and Q10, which are powered by an auxiliary 20-volt supply.

The differential amplifier, its voltage reference and the transistors that maintain a constant current through the voltage reference are located on oven board assembly A1. The oven maintains these components in a constant-temperature environment to provide highly stable operation.

The input to the differential amplifier is applied from a voltage divider across the supply output. Any change in output voltage changes the bias on the differential amplifier and, consequently, changes the collector current on the output half of this stage. This changes the drive on amplifiers Q4, Q6, and Q7. The changed output of Q7 changes the drive of Q2, and therefore of series regulator Q1. This change in drive on Q1 is in the correct direction to oppose any change in the supply output voltage.



For example, if the output voltage tends to increase, the forward bias on the input stage of the differential amplifier increases. This reduces the collector current of the output half of this stage, reducing the drive of amplifiers Q4, Q6, and Q7. The reduced collector current of Q7 lowers the forward bias of driver Q2. The reduced collector current of Q2 reduces the forward bias of series regulator Q1, increasing its effective resistance. The increased resistance of Q1 increases the voltage drop across it, reducing the output voltage.

#### 3-4 CURRENT-LIMITING CIRCUIT

The current-limiting circuit consists of transistor Q8, diode CR18, and their associated components. This stage is connected across the auxiliary 20-volt supply. The current through resistors R21 and R25 through R27 sets the normal bias on this stage. Potentiometer R27 sets the range of CURRENT LIMIT ADJ R25. This potentiometer is adjusted to forward bias transistor Q8 at the current-limiting point.

When the output load demand exceeds the value set by potentiometer R25, transistor Q8 conducts heavily. The collector current of Q8, flowing through R29, forward biases diode CR18. When diode CR18 conducts, it reduces the forward bias of amplifier Q4. This reduces the drive of the series regulator transistor, lowering the output voltage.

Any further increase in load demand further reduces the bias on Q4, further reducing the output voltage. In this manner, the circuit will maintain the load current at the set value for loads down to a short circuit. When the output current demand is reduced, the circuit conditions reverse and the voltage regulating circuits regain control of the output.

# SECTION 4

## 4) MAINTENANCE

### 4-1 GENERAL

Under normal conditions, no special maintenance of the Model 2005 is required. If servicing is necessary, the information in this section should be read thoroughly before starting repair or calibration.

### 4-2 ADJUSTMENT AND CALIBRATION

Make the following adjustments whenever a component is replaced or periodic recalibration is scheduled:

#### a) Preliminary Meter Adjustment:

- (i) Mechanically zero the meter using the adjustment screw on the front panel.
- (ii) NOTE: Before completing any meter adjustment, lightly tap the meter face. This will overcome any pivot friction and insure proper calibration.
- (iii) Set the CURRENT LIMIT ADJ control fully clockwise.
- (iv) Connect a 40-ohm, 10-watt resistor, in series with a standard ammeter, across the output of the supply.
- (v) Set the AC switch to ON and adjust the output voltage controls for a convenient reading, approximately ampere on a standard ammeter.
- (vi) Set the meter switch to MA.
- (vii) Adjust potentiometer R42 (on the board behind the meter) until the panel meter reading agrees with that of the standard ammeter.

#### b) Zero Voltage Calibration:

- (i) Connect a high precision voltmeter across the output of the supply.
- (ii) Set the RANGE switch to the 0-10V position and the output voltage controls for 0.000 volt output.
- (iii) Set the AC switch to ON and observe the voltmeter. If the voltmeter does not indicate 0.000 volt  $\pm 1$  MV, adjust CALIBRATE potentiometer R39 (on the rear panel) for this reading. If the adjustment is beyond the range of R39, proceed as follows:
  - (a) Set CALIBRATE potentiometer R39 to the middle of its range.
  - (b) Disconnect any jumper wires connected across resistors R9, R13, R40 and/or R41.
  - (c) Connect jumper wires, in various combinations, across resistors R9, R13, R40, and R41 until the output is within 2.5 MV of zero. Solder the jumper wires in these positions.
  - (d) Adjust CALIBRATE potentiometer R39 for an output of 0.000 volt  $\pm 1$  MV.

#### c) 20-Volt Adjustment:

NOTE: Make this adjustment only after the zero voltage calibration.

- (i) Set the RANGE switch to 10-20V and adjust the supply output to 20.000 volts. Set the VERNIER control fully counterclockwise.
- (ii) Check that the dots on the VERNIER control and front panel are aligned. A setscrew is located in the VERNIER control for any necessary adjustment.
- (iii) Set the VERNIER control to 0.
- (iv) Connect a high precision voltmeter across the output of the supply.
- (v) Set the AC switch to ON and observe the voltmeter.

- (vi) If necessary, adjust potentiometer R12 (on the amplifier board) until the voltmeter reads  $20.000 \pm 0.007$  volts.
- d) CURRENT LIMIT ADJ Range Adjustment:
  - (i) Set the power supply output voltage to 20.000 volts.
  - (ii) Set the meter switch to MA.
  - (iii) Set potentiometer R27 (on the amplifier board) to the center of its range.
  - (iv) Adjust CURRENT LIMIT ADJ potentiometer R25 through its entire range while depressing CURRENT LIMIT SET push-button S3.
  - (v) Adjust potentiometer R27 until the CURRENT LIMIT ADJ potentiometer varies the output current from 0 to 500 MA over its entire range.
  - (vi) Set the CURRENT LIMIT ADJ potentiometer to the desired maximum output current, or set it fully clockwise/

#### 4-3 TROUBLE SYMPTOMS AND SUGGESTED REMEDIES

- a) Circuit faults can be isolated most rapidly by measuring the voltage and resistance. Use the data given on the schematic diagram in the Appendix as a first step in servicing the supply. **CAUTION: WHEN UNSOLDERING SEMICONDUCTORS FOR TEST, USE A HEAT SINK TO PREVENT THERMAL DAMAGE. A LONG NOSE PLIERS BETWEEN THE SEMICONDUCTOR AND THE SOLDER JUNCTION IS ADEQUATE. NEVER OPERATE THE POWER SUPPLY WITH ANY LEADS DISCONNECTED OR SEMICONDUCTORS REMOVED. OPERATING POTENTIALS IN THE DC AMPLIFIER MAY CHANGE RADICALLY WHEN A COMPONENT IS REMOVED OR DISCONNECTED.**
- b) Power Supply Does Not Go On : If the OVEN and AC lamps do not light, check the AC fuse. If the fuse blows repeatedly, check the oven circuit and diodes CR1, CR2 and CR4 through CR7. Use an ohmmeter to take a resistance reading across each diode. Then, reverse the meter leads and take another reading. If one reading is not at least five times greater than the other, the diode is defective. If one diode in any pair is defective, replace both. A short circuit in one will produce high surge currents in the other, which can result in junction damage.
- c) No DC Output Voltage: If both the AC and OVEN lamps light, but no output voltage is available, insure that the CURRENT LIMIT ADJ control is not turned fully counterclockwise. Set the meter switch to MA and increase the output voltage. If no current is indicated, check the DC fuse and input capacitor C1. If current is present when the output-voltage controls are adjusted, check safety diode CR12 and for incorrect programming or sensing connections. Diode CR12 is connected in the opposite polarity to the DC output voltage. If the reverse current flow is greater than 1 ampere, this diode may weld, placing a permanent short circuit across the supply output. Normal operation can be restored by replacing the diode (located on the amplifier board).
- d) Regulator Failure : Check for correct potentials on amplifier transistors, voltage reference, etc. If any voltage appears incorrect, disconnect AC power and make a rapid check for defective transistors. This can be done without removing the transistors from the circuit. Use an ohmmeter set to its low resistance scale (R x1), and measure the forward and reverse resistances at the collector-base and base-emitter junctions. A resistance ratio of less than 5 to 1 indicates that the transistor is defective. Carefully remove it and check it on a transistor checker. **CAUTION: THIS TEST IS NOT RECOMMENDED FOR HIGH FREQUENCY OR LOW CURRENT DEVICES IN OTHER INSTRUMENTATION, AS CURRENTS FROM SOME OHMMETERS MAY BE SUFFICIENT TO DAMAGE SMALL SEMICONDUCTOR JUNCTIONS.**
- e) To test a component located in the oven:
  - (i) Unplug the line cord and remove the cover from the power supply.

- (ii) Loosen the three screws that secure the oven cover.
  - (iii) Rotate the cover counterclockwise and pull it away from the oven.
  - (iv) Remove the two screws that secure the oven cap; then remove the cap.
  - (v) Reach into the oven and extract the oven board. NOTE: To test the oven board while the unit is operating, remove it from its socket and insert a test adapter (Vector Electronic Corp. Type P-9-N-S, or equal) in its place. The board can then be plugged into the adapter.
  - (vi) To reassemble the oven, replace the board and cap. Secure the cap in position with two screws. Slide the oven cover down until the screws slide into the slots in the cover. Turn the cover clockwise and tighten the three screws.
- f) Poor Regulation, High Ripple: No specific check can be suggested since failure to regulate within specifications may be caused by any of the components in the supply. Make a point-to-point voltage and resistance check. Check all capacitors for open circuits and all electrolytic capacitors for excessive leakage. Make stage-gain measurements by changing the output load current and noting the change in base current of each amplifier stage. Use low resistance milliammeters and microammeters to avoid upsetting the regulator. The open-loop current gain of the regulator should be more than 106 from the base current of the input differential amplifier to the collector current of the series regulator.

# APPENDIX

## INTRODUCTION

This appendix contains an electrical parts list, schematic diagram, parts location diagram and equipment warranty.

## ELECTRICAL PARTS LIST

All electrical and electronic parts are listed in the sequence of their circuit numbers as shown on the schematic diagram. A brief description of each part is given, followed by the code number of the manufacturer and his part number. All manufacturers' code numbers are taken from Cataloging Handbooks H4-1 and H4-2, Federal Supply Code for Manufacturers. These handbooks are available through Federal Agencies. They may also be ordered directly from the Superintendent of Documents, U. S. Government Printing Office, Washington, D.C. 20402.

We recommend that all parts having the code number 98095 be ordered directly from Power Designs Inc. The commercial equivalents of these parts either have wide parameter tolerances or require special factory inspection or modification before they are suitable for use in the power supply.

All components used in the power supply or supplied as replacements are carefully inspected at the factory. Inspections are performed on a 100% basis or at AQL levels in accordance with Military Specification MIL-Q-9858 under which Power Designs Inc. has been qualified.

All semiconductors are inspected on a 100% basis. They are inspected not only for operating parameters, but also for critical characteristics related to reliability and predictable life expectancy. Some of those characteristics are observed when the device is taken beyond its normal operating regions. These test techniques have been developed under a "predictable-reliability" program in operation at Power Designs Inc. for the past ten years. Under this program, quality- control procedures are constantly reevaluated and updated as new advances are made in solid-state technology and additional experience is gleaned from field history.

Semiconductor manufacturers are constantly modifying their products. Complete lines are frequently discontinued and replaced by devices having improved gain, operating voltage levels and frequency response. The high-gain, closed-loop DC amplifiers used in regulator circuits are particularly sensitive to slight changes in these parameters. Commercial or military "equivalent" transistors used as replacements may affect the power supply performance. Compliance with the original specifications can be assured if replacement semiconductors are ordered from the factory.

All replacement semiconductors are processed and stocked at the factory to insure complete interchangeability with the devices in the original equipment. To insure that proper replacements are provided, the original devices are coded with a Power Designs Inc. part number as follows:

Semiconductor Manufacturer' s Code	Power Designs Inc. Type	Suffix Identifying Special Parameters
------------------------------------	-------------------------	---------------------------------------

When ordering replacements, please identify the device as completely as possible, listing the model and serial number if available.

In some cases, the replacement part received may have a different part number from that given in the Electrical Parts List. This can be due to several factors:

- A different prefix indicates that Power Designs Inc. is using a different vendor source. The operating characteristics of the devices are identical.
- A completely different part number indicates:
  - The original vendor discontinued manufacture of the item or could no longer manufacture it to the original specifications
  - A better device for use in the particular circuit has been substituted.
  - Tighter controls for interchangeability have provided greater assurance of

# ADDENDA

The Schematic Diagram and Electrical Parts List have been modified as follows:

1. Capacitor C21 has been added directly across CR9 on the auxiliary board. This capacitor is tantalum, 10 uf, 35 vdc, part number CE-106-.35 (manufacturer 98095).
2. Capacitor C22 has been added across diode CR14. This is plastic film, 0.01 uf, 200 vdc, part number CP-16-2 (manufacturer 98095).

# ELECTRICAL PARTS LIST

NOTE: When replacing semiconductors or investigating their part numbers, note the information in paragraph 2 above.

## ELECTRICAL PARTS LIST

Circuit Number	Description	Mfr Code Number	Part Number
C1	Capacitor,electrolytic,1000 uf, 50 vdc	98095	CE-94-.5
C2,C3	Capacitor,electrolytic,100 uf, 80 vdc	98095	CE-91-.8
C4	Capacitor,electrolytic,8 uf,100 vdc	98095	CE-42-1
C5	Capacitor,electrolytic,400 uf, 85 vdc	98095	CE-83-.85
C6	Capacitor, ceramic disc,0.02 uf, 500 vdc	98095	CC-23-5
C7	Capacitor,electrolytic,100 uf,80 vdc	98095	CE-91-.8
C8	Capacitor, plastic film,0.1 uf, 200 vdc	98095	CP-17-2
C9	Capacitor, ceramic disc,0.05 uf, 600 vdc	98095	CC-34-6
C10,C11	Capacitor, plastic film,0.1 uf, 200 vdc	98095	CP-17-2
C12	Capacitor, ceramic disc,0.01 uf, 1 kvdc	98095	CC-13-10
C13	Capacitor, plastic film,680 pf, 200 vdc	98095	CP-27-2
C14	Capacitor, ceramic disc,0.01 uf, 1 kvdc	98095	CC-13-10
C15	Capacitor, ceramic tubular,330 pf, 500 vdc	98095	CC-26-5
C16,C17	Capacitor, ceramic disc,1 uf, 3 vdc	98095	CC-100M3AD
C20,C21	Capacitor,tantalum,10 uf, 35 vdc	98095	CE-106-.35
CR1 thru CR7	Diode, silicon	98095	G144
CR8, CR9	Diode, silicon, zener	98095	UZ587
CR10, CR11	Diode, silicon, zener	98095	AC359C, D
CR12	Diode, silicon	98095	GI44
CR13	Diode, silicon, zener (See Note 1)	98095	AC359BT
CR14 thru CR21	Diode, silicon	98095	GI44
CR22	Diode, silicon, zener	98095	AC359C,D
F1	Fuse, "Slo-Blo," 3/8 ampere	71400	MDL3/8
F2	Fuse, "Slo-Blo," 1 ampere	71400	MDL 1
I1, I2	Lamp assembly, neon	98095	PLA-7



Circuit Number	Description	Mfr Code Number	Part Number
I3	Lamp assembly, neon	98095	PLA-10
M1	Meter, volt-ammeter, 0-25 V, 0-500 MA	98095	MVA-109
Q1	Transistor, silicon, NPN	98095	RC1700
Q2	Transistor, silicon, PNP	98095	MS1028A
Q3	Transistor, silicon, NPN	98095	MS2270/U
Q4	Transistor, silicon, PNP	98095	MS1028L
Q5	Transistor, dual, silicon,NPN(See Note1)	98095	AS2056
Q6 thru Q8	Transistor, silicon, NPN	98095	MS2270/U
Q9, Q10	Transistor, silicon, PNP	98095	MS1028A
R1	Resistor,wirewound,1 k ohm, 5%, 5 w	98095	RW-102-3DA
R2	Resistor,wirewound,800 ohms,5%, 5 w	98095	RW-801-3DA
R3	Resistor,composition,390 ohms,5%,1/2 w	01121	EB3915
R4	Resistor, precision, metal film,150 k ohms,1%,* w	98095	RD-154-1QA
R5	Resistor, composition, 6.8 megohms to 15 megohms, 10%,1/2 w (precise value selected on test)	01121	Type EB
R6	Resistor, precision, metal filrn,562 ohms,1%,* w	98095	RD-5620-1QA
R7	Resistor, composition, 4.7 k ohms,10%,1/2 w	01121	E34721
R8	Resistor, precision, metal film, 22.1 k ohms,1%,1/4 w	98095	RD-2212-1QA
R9	Resistor, precision, metal film, 16.2 k ohms,1%,1/4 w	98095	RD-1622-1QA
R10	Resistor, precision, metal film, 35.7k ohms,1%,1/4w	98095	RD-3572-1QA
R11	Resistor, precision, wirewound, 5.2k ohms,1%,1/4w	98095	RW-522-8QA
R12	Resistor, variable, wirewound, 200 ohms,10%,3w	98095	RWV-201K4-.68
R13	Resistor, precision, metal film, 8.25k ohms,1%,1/4w	98095	RD-8251-1QA
R15	Resistor, composition, 1.8k ohms,5%,1/2 w	1121	EB1825
R16	Resistor, composition, 560 ohms,10%,1/2 w	1121	EB5611
R17	Resistor, composition, 4.7k ohms,10%,1/2 w	1121	EB4721
R18	Resistor, composition, i.8k ohms,10%,1/2 w	1121	EB1821
R19	Resistor, composition, 560 ohms,10%,1/2 w	1121	EB5611

Circuit Number	Description	Mfr Code Number	Part Number
R20	Resistor, composition, 100 ohms,10%,1/2 w	1121	EB1011
R21	Resistor, wirewound, 2 ohms,5%, 5 w	98095	RW-020-3DA
R22	Resistor, precision, metal film, 475 ohms,1%,1/4w	98095	RD-4750-1QA
R23	Resistor, precision, metal film, 150 ohms,1%,1/4w	98095	RD-151-1QA
R24	Resistor, composition, 5.6 k ohms,10%,1/2 w	1121	EB5621
R25	Resistor, variable, wirewound, 1 k ohm,10%, 2 w	98095	RWV-102C4-.78
R26	Resistor, composition, 4.7 k ohms,10%,1/2 w	1121	EB4721
R27	Resistor, variable, wirewound, i k ohm, 10%,1 1/4w	98095	RWT-102-C4
R28	Resistor,composition,3.9 k ohms, 10%,2 w	1121	HB3921
R29	Resistor,composition,22 k ohms, 5%,1/2 w	1121	EB2235
R30	Resistor,composition,2.7 k ohms, 10%,1/2 w	1121	EB2721
R31	Resistor, wirewound, 500 ohms, 5%,5 w	98095	RW-501-3DA
R32	Resistor,composition,560 ohms, 10%,1/2 w	1121	EB5611
R33	Resistor, precision, wirewound, 24.9k ohms,0.5%,*w	98095	RW-2492-6QA
R37,R38	Resistor, precision, metal film, 221 ohms,1%,1/4w	98095	RD-2210-1QA
R39	Resistor, variable, wirewound, 5 k ohms,10%,4 w	98095	RWV-502M4-.87
R40	Resistor, precision, metal film, 4.32 k ohms,1%,1/4w	98095	RD-4321-1QA
R41	Resistor, precision, metal film, 32.4 k ohms,1%,1/4w	98095	RD-3242-1QA
R42	Resistor, variable, wirewound, 50 ohms,10%,1 1/4w	98095	RWT-500-C4
R43	Resistor, wirewound, 0.2 ohm shunt	98095	RW-FA-4A
R45	Resistor, precision, wirewound, 10 k ohms,0.1%,0.4w	98095	RW-103-8UR
R46	Resistor, variable, wirewound, 1 ohm,10%,2 w	98095	RWV-010C4-.81
R47	Resistor, precision, wirewound, 1 k ohm, 0.1%, 0.4w	98095	RW-102-8UR
R48,R49	Resistor, precision, wirewound, 2 k ohms,0.1%,0.4w	98095	RW-202-8UR
R50	Resistor, precision, wirewound, 5 k ohms,0.1%,0.4w	98095	RW-502-8UR

Circuit Number	Description	Mfr Code Number	Part Number
R51	Resistor,composition,4.7 k ohms,10%, 1/4 w	1121	CB4721
R52	Resistor,composition,6.8 k ohms,10%, 1/4 w	1121	CB6821
R53	Resistor,composition,18 k ohms,10%, 1/4 w	1121	CB1831
R54	Resistor,composition,27 k ohms,10%, 1/4w	1121	CB2731
R55	Resistor,precision,wirewound,100 ohms, 0.1%,0.4w	98095	RW-101-8UR
R56,R57	Resistor, precision, wirewound, 200 ohms,0.1%,0.4w	98095	RW-201-8UR
R58	Resistor, precision, wirewound, 500 ohms, 0.1%,0.4w	98095	RW-501-8UR
R59	Resistor, composition, 470 ohms, 10%,1/4 w	1121	CB4711
R60	Resistor, composition, 680 ohms,1 0%,1/4 w	1121	CB6811
R61	Resistor, composition, 1.8 k ohms, 10%,1/4, w	1121	CBi821
R62	Resistor, composition, 2.7 k ohms, 10%,1/4 w	1121	CB2721
R63	Resistor, precision, wirewound, 10 ohms,1%, 0.4 w	98095	RW-100-1UR
R64,R65	Resistor, precision, wirewound, 20 ohms, 0.5%,0.4 w	98095	RW-200-6UR
R66	Resistor, preeision, wirewound,50 ohms ,0. 5%,0. 4 w	98095	RW-500-6UR
R67	Resistor, composition, 47 ohms,10%,1/4 w	1121	CB4701
R68	Resistor, composition, 68 ohms, 10%, w	1121	CB6801
R69	Resistor,composition,180 ohms, 10%, 1/4 w	1121	CB1811
R70	Resistor,composition,270 ohms,10%, 1/4 w	1121	CB2711
R71	Resistor,precision,wirewound,1 ohm, 3%, 0.4 w	98095	RW-O10-7UR
R72,R73	Resistor,precision,wirewound,2 ohms,3%, 0.4 w	98095	RW-020-7UR
R74	Resistor,precision,wirewound,5 ohms,3%, 0.4 w	98095	RW-050-7UR
R75	Resistor,composition,4.7 ohms,10%,1/4 w	1121	CB47G1
R76	Resistor,composition,6.8 ohms,10%,1/4 w	1121	CB68G1
R77	Resistor,composition,18 ohms,10%,1/4 w	1121	CB1801
R78	Resistor,composition,27 ohms,10%,1/4 w	1121	CB2701
R79	Resistor,composition,200 ohms,5%,1/2 w	1121	EB2015
R80	Resistor, precision, metal film (See Note1)		

Circuit Number	Description	Mfr Code Number	Part Number
R81	Resistor, composition, 1.5 k ohms, 5%, 1/2 w	1121	EB1525
R82	Resistor, composition, 47 k ohms, 10%, 1/2 w	1121	EB4731
R83	Resistor, precision, metal film, (See Note 1)		
RT1	Disc thermistor, 1000 ohms, 10%, at 25°C	73168	KA31L1
S1	Switch, toggle, SPST	98095	ST-S
S2	Switch, toggle, DPDT	98095	ST-16
S3	Switch, pushbutton, SPST	98095	ST-19
S4	Switch, toggle, DPDT	98095	ST-16
S5	Switch, rotary	98095	PS-2005-7-3
S6	Switch, rotary	98095	PS-2005-7-4
T1	Transformer, power	98095	TTM-56
Z1	Oven Assembly	98095	PS-2005-1

NOTE 1: This item is a matched component. If it requires replacement, the complete oven board should be sent back to the factory for repair and recalibration. When the repaired and recalibrated board is returned by the factory, the procedure described in paragraph 4-2b of the manual should be followed. It may also be necessary to retrim resistor R11 and/or adjust the value of R80. To do this, set potentiometer R12 approximately 2/3 clockwise and, using a high precision voltmeter, measure the voltage across R45 (located on board at rear of decade switch assembly) with switch S4 in "10V-20V" position. Trim R11 and/or adjust the value of R80 (using type RN60 precision resistors) until the voltage across R45 reads close to 10.00 volts.

(An alternative to the foregoing procedure is to return the entire unit to the factory for repair and recalibration).

<b>CODE LIST OF MANUFACTURERS</b>		
Code Number	Manufacturer	Address
01121	Allen-Bradley Company	Milwaukee, Wisconsin
71400	Bussman Manufacturing Div.	St. Louis, Missouri
73168	Fenwal, Inc.	Ashland, Massachusetts
98095	Power Designs Inc.	Westbury, New York

### Simplified Schematic

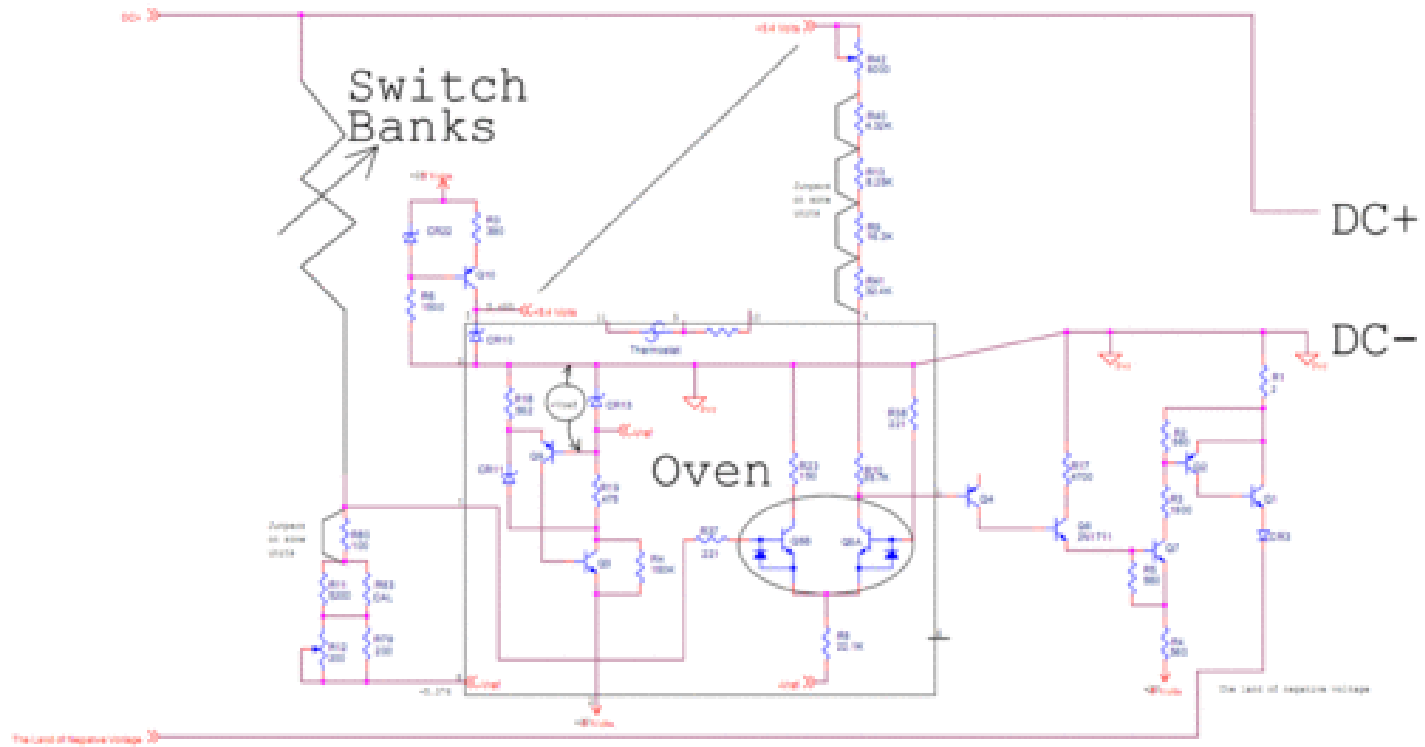

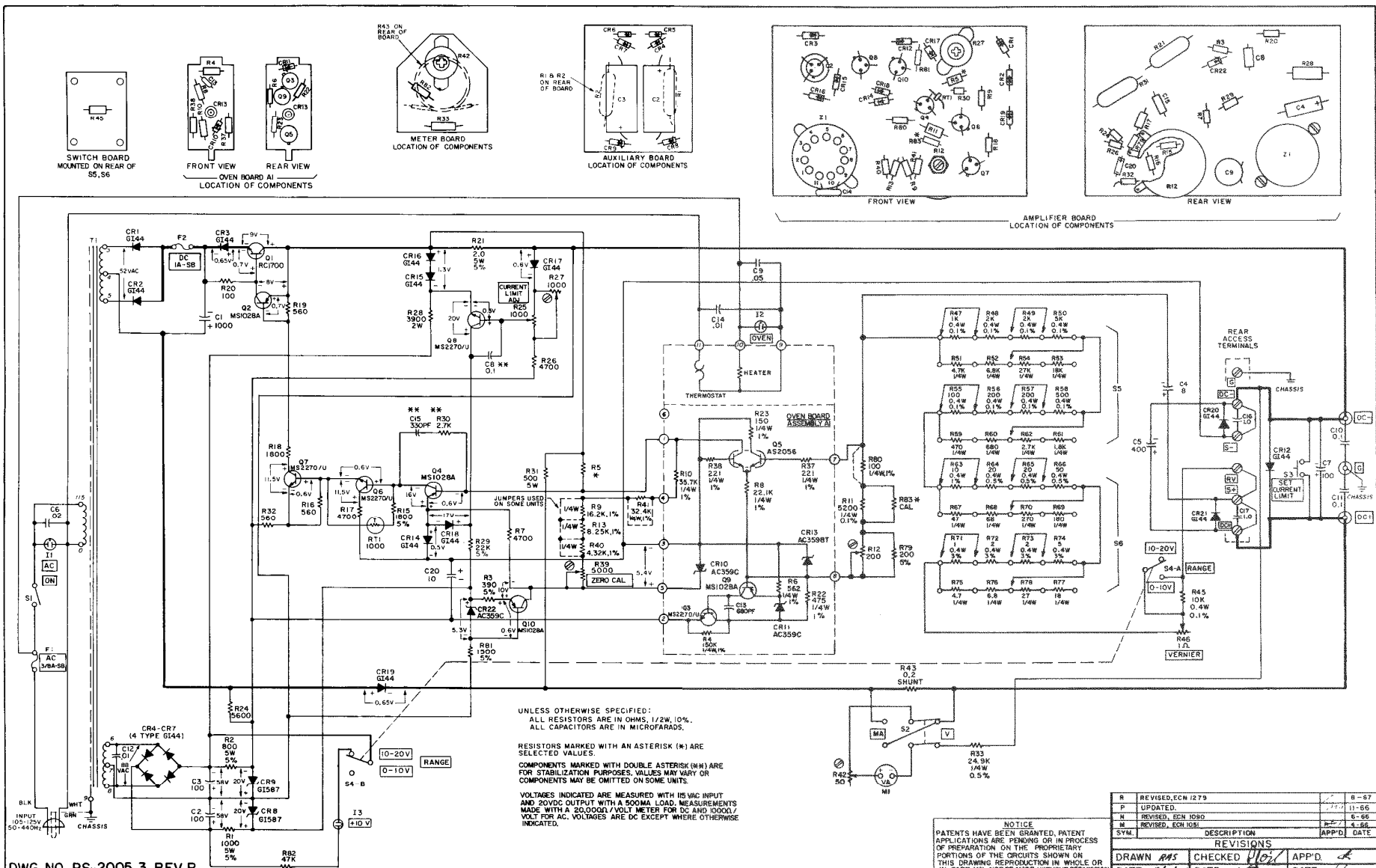

DWG. NO. PS-2005-3 REV R  
 MODEL 2005  
 TRANSISTORIZED POWER SUPPLY

0-20VDC, 0-500MA

UNLESS OTHERWISE SPECIFIED:  
 ALL RESISTORS ARE IN OHMS, 1/2W, 10%.  
 ALL CAPACITORS ARE IN MICROFARADS.  
 RESISTORS MARKED WITH AN ASTERISK (\*) ARE  
 SELECTED VALUES.  
 COMPONENTS MARKED WITH DOUBLE ASTERISK (\*\*) ARE  
 FOR STABILIZATION PURPOSES. VALUES MAY VARY OR  
 COMPONENTS MAY BE OMITTED ON SOME UNITS.  
 VOLTAGES INDICATED ARE MEASURED WITH 1% INAC INPUT  
 AND 20VDC OUTPUT WITH A 500MA LOAD. MEASUREMENTS  
 MADE WITH A 20,000Ω/VOLT METER FOR DC AND 10,000Ω/  
 VOLT FOR AC. VOLTAGES ARE DC EXCEPT WHERE OTHERWISE  
 INDICATED.

NOTICE  
 PATENTS HAVE BEEN GRANTED. PATENT  
 APPLICATIONS ARE PENDING OR IN PROCESS  
 OF PREPARATION ON THE PROPRIETARY  
 PORTIONS OF THE CIRCUITS SHOWN ON  
 THIS DRAWING REPRODUCTION IN WHOLE OR  
 IN PART MAY NOT BE MADE WITHOUT PERMISSION

R	REVISED, ECH 1279	8-57	
F	UPDATED	11-56	
R	REVISED, ECH 1080	8-56	
M	REVISED, ECH 1081	4-56	
SYM.	DESCRIPTION	APP'D	DATE
REVISIONS			
DRAWN	MS	CHECKED	11/1/57
DATE	8/10/67	DATE	11/26/67

POWER DESIGNS INC.  
 NEW YORK

# WARRANTY

POWER DESIGNS INC., warrants to the original purchaser, each instrument sold by us, or our authorized agents, and all the parts thereof, to be free from defects in material or workmanship under normal use and service within the specified ratings and operating conditions.

Its obligation under this warranty is hereby limited to the repair or replacement of any instrument, or part thereof, which is returned to us within one year after delivery, and which shall prove, after our examination, to be thus defective.

This warranty does not include the cost of transportation charges to and from the factory and/or the cost of packaging or crating of instruments for return to the factory, unless such instrument is returned within thirty (30) days from the date of original shipment as shown on the packing list or shipping documents, and prior written authorization for such costs is obtained from the factory.

The repair or replacement of an instrument, or any part thereof, does not void or extend the original warranty.

POWER DESIGNS INC., reserves the right to discontinue any instrument without notice, or to make modifications in design at any time, without incurring any obligation to make these modifications in instruments previously sold.

POWER DESIGNS INC.  
Westbury, L I., New York

POWER DESIGNS PACIFIC, INC.  
Palo Alto, California