

MODEL **1544**

1-3012 V  
0-20 MA

MODEL **1547**

1-3012 V  
0-40 MA

PHOTO MULTIPLIER AMPLIFIERS  
RADIATION MONITORS  
PARTICLE DETECTORS  
ELECTRON OPTICS  
MICROWAVE POWER

# PRECISION DC HIGH VOLTAGE SOURCE



The exceptional performance of the Model 1544 and Model 1547 is achieved through the combination of vacuum tube high voltage capability with sophisticated semiconductor techniques common in low voltage systems.

An order of magnitude improvement in operating parameters is achieved with the replacement of all vacuum tubes except for the "series regulator" by a temperature stabilized silicon transistor amplifier and solid state voltage references.

Fast acting electronic overload protection\* permits continuous operation without damage into a short circuit. Function is automatically restored upon fault clearance.

\* Robotec Patent No. 3,083,330

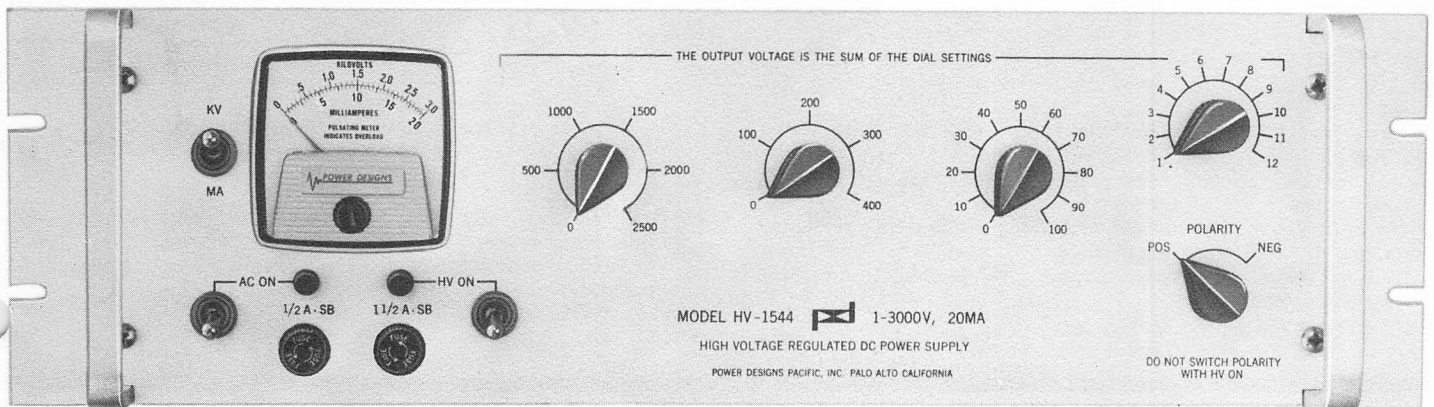

**MODEL 1544 & 1547** 1-3012 V • 0-20 MA (Model 1544)  
1-3012 V • 0-40 MA (Model 1547)

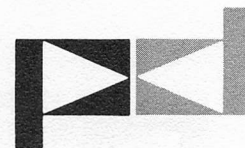

# PRECISION DC HIGH VOLTAGE SOURCE

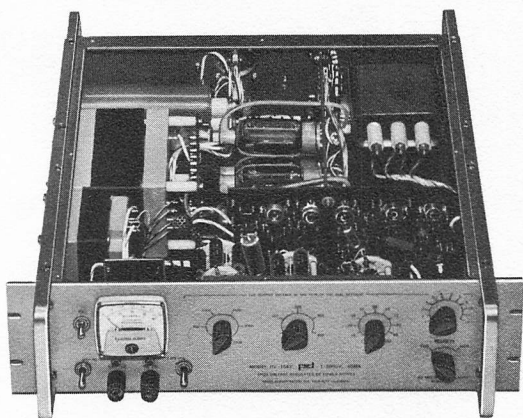

## DESIGN FEATURES

- Vacuum tube/semiconductor regulator system prevents voltage overshoot on turn-on or turn-off and eliminates time delay relay circuits.
- Silicon semiconductor amplifier with low noise differential amplifier input stage, and better than 50 microsecond response time.
- \*Fast, self-indicating electronic overload and short circuit protection permitting continuous operation into a short circuit with automatic restoration upon fault clearance. Pulsating voltmeter needle signals overload.
- Corona free epoxy encapsulated transformers with multiple electrostatic shielding.
- Prestabilized solid state voltage reference with .001%/°C temperature coefficient and 15 microvolt noise level.
- Precision 4-dial voltage control calibrated to better than 0.25% utilizing low leakage ceramic and delrin switches and 5 PPM sealed wirewound resistors. Resettable to 0.1%.
- High resolution voltage output vernier potentiometer with precision metal wiper arm and resistance card with soldered end contacts.
- Glow discharge tubes protect transistors and precision divider resistors against high voltage transients.
- Lifetime silicon high voltage rectifier employing one ampere diodes in a multiple series configuration with built-in switching transient suppression. Voltage derated to 50% of maximum operating potentials.
- Electronic current limiter holds output to 125% of rating protecting loads such as sensitive photomultiplier tubes and permitting use as a capacitor charging source.
- BNC "safety" high voltage output receptacles safeguard against accidental insertion of low voltage coaxial leads and connectors.
- Dual volt-ammeter for output voltage or current monitoring.
- Low leakage plastic dielectric output and feedback capacitors in high voltage circuits. Computer grade electrolytic capacitors in low voltage circuits.
- Polarity reversing switch permits supply operation with either positive or negative output terminal at ground potential.
- Line and load circuits separately fused. Accessible at front panel. Separate HV on-off switch.
- Front and rear handle/rail construction provides ease in bench handling or relay rack installation.
- Fifty hour pre-aging of power supply prior to final test insures field service reliability.

\*ROBOTEC® Patent No. 3,083,330  
REP. 5M 9-64 PRINTED IN U.S.A.

## ELECTRICAL SPECIFICATIONS

- OUTPUT:** 1 Volt to 3012 Volts D-C, continuously adjustable.  
Model 1544: 0-20 milliamperes maximum.  
Model 1547: 0-40 milliamperes maximum.
- INPUT:** 105-125 Volts, 50-440 Cycles.  
Model 1544: \*110 Watts.  
Model 1547: \*231 Watts.
- REGULATION:** 0.001% plus 2 millivolts for line or load variations over the operating range.
- RIPPLE:** 1 millivolt peak to peak, maximum.
- RESPONSE TIME:** Less than 50 microseconds to return to within regulation limits for 100% step change in rated load.
- STABILITY:** Less than .005% drift in output voltage per hour; less than 0.02% drift per 24 hour period at constant ambient temperature after warm-up.
- VOLTAGE CONTROLS:** Precision calibrated voltage divider:  
0 to 2500 Volts in five 500 Volt steps  
0 to 400 Volts in four 100 Volt steps  
0 to 100 Volts in ten 10 Volt steps  
1 to 12 Volts fine adjustment potentiometer
- CALIBRATION ACCURACY:** 0.25% of the voltage control dial readings from 250-3012 Volts; 1.0% or 100 millivolts (whichever is greater) from 1-250 Volts.
- RESOLUTION:** 10 millivolts (fine adjustment potentiometer).
- RESETTABLE:** 0.1% or 100 millivolts.
- TEMPERATURE COEFFICIENT:** 25 parts per million per °C change in ambient after warm-up.
- OPERATING TEMPERATURE:** Continuous duty at full load from 0-50°C ambient.
- OUTPUT TERMINALS:** Two BNC "safety" high voltage receptacles on rear chassis surface.
- POLARITY REVERSING SWITCH:** Panel reversing switch permits operation with either positive or negative output terminal at ground potential.

\*At nominal line voltage.

## MECHANICAL SPECIFICATIONS

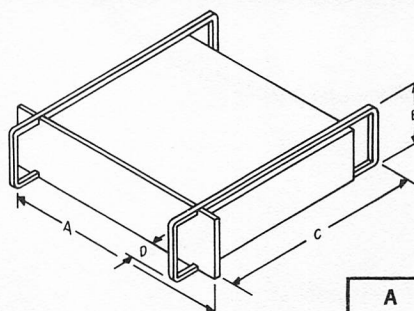

DIMENSIONS:

	A	B	C	D
Model 1544:	19"	5¼"	16"	1½"
Model 1547:	19"	5¼"	16"	1½"

**WEIGHT:** Model 1544: 27 lbs.  
Model 1547: 33 lbs.

**FINISH:** Smooth light grey vinyl synthetic enamel panel with black nomenclature. Golden alodine chassis. Grey epoxy enamel perforated metal dust covers. Brushed anodized natural aluminum handles and rails.

MODEL 1544 ..... \$543.00 F.O.B. WESTBURY  
MODEL 1547 ..... \$595.00 F.O.B. WESTBURY

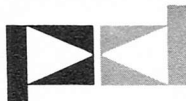

**POWER DESIGNS INC.**  
1700 SHAMES DRIVE • WESTBURY, N. Y.  
516 EDgewood 3-6200 TWX: 510-222-6561

**POWER DESIGNS PACIFIC, INC.**  
3381 JUNIPERO SERRA • PALO ALTO, CALIFORNIA  
415-321-6111 TWX: 910-373-1251

FEC

**INSTRUCTION MANUAL**

**POWER SUPPLY**

MODEL 1544 SERIAL \_\_\_\_\_

POWER SUPPLY HV-1544

ADDENDUM

1. SCHEMATIC DIAGRAM - THE FOLLOWING CHANGES HAVE BEEN MADE TO THE SCHEMATIC DIAGRAM.

- 1.1 THE POWER RATING OF R17 HAS BEEN CHANGED FROM 1/4 WATT TO 1/3 WATT.
- 1.2 THE POWER RATING OF R18 HAS BEEN CHANGED FROM 3/8 WATT TO 1/3 WATT.
- 1.3 THE VALUE OF RESISTOR R32 HAS BEEN CHANGED FROM 220K $\Omega$  TO 68 K $\Omega$ .
- 1.4 THE POWER RATINGS OF R51 AND R52 HAVE BEEN CHANGED FROM 1/4 WATT TO 1 WATT.
- 1.5 THE POWER RATINGS OF R53 AND R54 HAVE BEEN CHANGED FROM 3/8 WATT TO 1 WATT.
- 1.6 DIODES CR16 THROUGH CR39 HAVE BEEN CHANGED FROM SS843 TO SS843V OR SS44V.
- 1.7 DIODES CR1 THROUGH CR4, CR10, CR14, CR15, CR41 AND CR42 HAVE BEEN CHANGED FROM 1N645 TO SS44W.

INSTRUCTION MANUAL  
FOR  
TRANSISTORIZED POWER SUPPLIES  
MODELS NO. 1544 AND 1547

MODELS 1544 AND 1547 ARE REGULATED, HIGH VOLTAGE, DC POWER SUPPLIES DESIGNED TO OPERATE DEVICES WHICH REQUIRE DC POTENTIALS OF EXCEPTIONAL STABILITY AND UNUSUALLY LOW NOISE AND RIPPLE CONTENT.

THE REGULATOR CIRCUITS USE A SERIES REGULATOR TUBE DRIVEN BY AN ALL SILICON TRANSISTORIZED CONTROL AMPLIFIER. THE USE OF A TRANSISTOR AMPLIFIER PRODUCES A POWER SUPPLY WHOSE OPERATING CHARACTERISTICS ARE SIGNIFICANTLY SUPERIOR TO THOSE FOUND IN SUPPLIES WHICH MAKE USE OF A TUBE AMPLIFIER, PARTICULARLY IN STABILITY AND RESPONSE TIME. THIS ALSO MAKES IT POSSIBLE TO INCLUDE ELECTRONIC OVERLOAD PROTECTION CIRCUITS WHICH PROTECT THE SUPPLY FROM DAMAGE, EVEN UNDER SHORT-CIRCUIT CONDITIONS. THE SEMICONDUCTOR CIRCUITS ARE PROTECTED AGAINST DAMAGE WHICH COULD BE CAUSED BY VOLTAGE TRANSIENTS, ARCING IN THE SERIES REGULATOR TUBE OR SHORT-CIRCUITS SUDDENLY APPLIED TO THE OUTPUT LOAD.

UNUSUAL STABILITY OF THE OUTPUT VOLTAGE IS PROVIDED BY THE USE OF A TEMPERATURE COMPENSATED ZENER DIODE AS A REFERENCE, BY THE USE OF PRECISION WIRE-WOUND RESISTORS OF LOW TEMPERATURE COEFFICIENT IN ALL VOLTAGE DIVIDER CHAINS AND BY THE USE OF AN ALL-SILICON, TRANSISTORIZED, CONTROL AMPLIFIER, FULLY COMPENSATED FOR TEMPERATURE EFFECTS.

1. ELECTRICAL SPECIFICATIONS:

- 1.1 INPUT: (A) MODEL 1544--105-125 VOLTS, 50-400 CPS, SINGLE  $\phi$   
110 WATTS, AT 115V LINE.  
(B) MODEL 1547--105-125 VOLTS, 50-400 CPS, SINGLE  $\phi$   
231 WATTS, AT 115V LINE
- 1.2 TEMPERATURE: CONTINUOUS DUTY AT FULL LOAD AT ANY AMBIENT TEMPERATURE FROM 0°C TO 50°C.
- 1.3 OUTPUT: (A) MODEL 1544--1 TO 3012 VOLTS, 20 MA, MAX.  
(B) MODEL 1547--1 TO 3012 VOLTS, 40 MA. MAX.
- 1.4 REGULATION: LINE: 0.001% +2 MILLIVOLTS FOR LINE VARIATIONS WITHIN RANGE OF 105 TO 125 VOLTS AC.  
LOAD: 0.001% +2 MILLIVOLTS FOR CURRENT VARIATIONS FROM ZERO TO FULL LOAD.
- 1.5 RIPPLE: 1.0 MILLIVOLTS PEAK-TO-PEAK, MAXIMUM.
- 1.6 STABILITY: 0.005% PER HOUR; 0.03% PER 24 HOURS AT CONSTANT AMBIENT (AFTER 15 MINUTE WARM-UP)
- 1.7 TEMPERATURE COEFFICIENT OF OUTPUT VOLTAGE: 25 PARTS PER MILLION PER °C MAXIMUM.
- 1.8 CALIBRATION: THE OUTPUT VOLTAGE IS SET BY FRONT PANEL SWITCHES WHICH PROVIDE THE FOLLOWING STEPS:
- 0 TO 2500 VOLTS IN 5 STEPS OF 500 VOLTS EACH
- 0 TO 400 VOLTS IN 4 STEPS OF 100 VOLTS EACH
- 0 TO 100 VOLTS IN 10 STEPS OF 10 VOLTS EACH

A VERNIER, CALIBRATED FROM 1 TO 12 VOLTS, IS PROVIDED. THE OUTPUT VOLTAGE IS THE SUM OF THESE SETTINGS WITHIN 0.25% FOR OUTPUT VOLTAGES ABOVE 250 VOLTS AND WITHIN 1% OR 0.25 VOLTS FROM 1 TO 250 VOLTS.

- 1.9 RESOLUTION: 20 MILLIVOLTS (1-12 VOLT VERNIER POTENTIOMETER)
- 1.10 RESETTABILITY: 0.1%
- 1.11 RESPONSE TIME: OUTPUT VOLTAGE WILL RETURN TO REGULATION LIMITS WITHIN 50 MICROSECONDS DURING STEP CHANGES FROM ZERO TO FULL LOAD.
- 1.12 POLARITY: REVERSIBLE BY MEANS OF A FRONT PANEL SWITCH; EITHER POSITIVE OR NEGATIVE SIDE OF THE REGULATED OUTPUT MAY BE GROUNDED. A REAR MOUNTED SWITCH IS AVAILABLE AS A SPECIAL OPTION.
- 1.13 METERING: SELECTION OF OUTPUT VOLTAGE OR OUTPUT CURRENT PROVIDED BY TOGGLE SWITCH (SPRING RETURN TO VOLTAGE POSITION). INDICATION DISPLAYED ON SINGLE FRONT PANEL METER.
- 1.14 CIRCUIT PROTECTION: SEPARATE FUSES FOR MAIN AND AUXILIARY AC CIRCUITS. THE OVERLOAD PROTECTION SYSTEM INSURES THAT THE SUPPLY WILL NOT BE DAMAGED IF THE OUTPUT IS SHORTED CONTINUALLY OR REPEATEDLY OR OPERATED INDEFINITELY INTO AN OVERLOAD OR SHORT CIRCUIT. TRANSISTOR CIRCUITS ARE PROTECTED FROM DAMAGE DUE TO VOLTAGE TRANSIENTS OR ARCING IN THE SERIES REGULATOR TUBES.

## 2. MECHANICAL SPECIFICATIONS:

2.1 DIMENSIONS: THE SUPPLY IS DESIGNED TO MOUNT IN A STANDARD 19" RACK. DEPTH (INCLUDING HANDLES) IS 16" BEHIND THE FRONT PANEL. PANEL HEIGHT IS 5 1/4". WEIGHT IS 27 LBS., FOR THE MODEL 1544 AND 33 LBS., FOR THE MODEL 1547.

### 2.2 CONNECTORS:

2.2.1 HIGH VOLTAGE: THE HIGH VOLTAGE OUTPUT IS AVAILABLE ON TWO PARALLEL CONNECTORS AT THE REAR OF THE CHASSIS. THE CONNECTORS NORMALLY FURNISHED ARE TYPE KV-79-03 OR STAR 5134. THESE ARE SPECIAL BNC HIGH VOLTAGE CONNECTORS DESIGNED TO PREVENT ACCIDENTAL INSERTION OF STANDARD BNC PLUGS.

## 3. OPERATION:

- 3.1 INSTALLATION: ONLY EXTERNAL PHYSICAL INSPECTION OR PROCESSING IS REQUIRED. THE POWER SUPPLY IS READY FOR OPERATION AS SHIPPED FROM THE FACTORY.
- 3.2 CONTROLS: ONCE THE LINE CORD HAS BEEN PLUGGED INTO AN AC SOURCE, THE "AC ON" TOGGLE SWITCH MAY BE TURNED TO THE "ON" POSITION. THIS WILL ENERGIZE THE AUXILIARY POWER SUPPLIES AND THE HEATER OF THE SERIES REGULATOR TUBES. THE "AC ON" LIGHT SHOULD BE ILLUMINATED.

THE OUTPUT VOLTAGE SHOULD BE SET TO THE DESIRED LEVEL BY MEANS OF THE FRONT PANEL SELECTOR SWITCHES. THE OUTPUT VOLTAGE IS THE SUM OF THESE SETTINGS. THE VERNIER POTENTIOMETER PROVIDES FOR PRECISE OUTPUT VOLTAGE ADJUSTMENT.

THE POLARITY SWITCH SHOULD BE SET FOR THE DESIRED OUTPUT POLARITY.

THE "HV ON" TOGGLE SWITCH MAY NOW BE SET TO THE "ON" POSITION. THIS WILL LIGHT THE "HV ON" LIGHT AND ENERGIZE THE HIGH VOLTAGE CIRCUITS PROVIDING REGULATED OUTPUT VOLTAGE.

IT SHOULD BE NOTED THAT NO TIME DELAY IS INCLUDED IN THE HV CIRCUITS. THE HV SWITCH MAY BE OPERATED SIMULTANEOUSLY WITH THE AC SWITCH WITHOUT DAMAGE TO THE UNIT, OR OUTPUT VOLTAGE OVERSHOOT, SINCE THE SEMICONDUCTOR CONTROL CIRCUITS REQUIRE NO WARM-UP TIME. THE OUTPUT VOLTAGE WILL RISE MORE SLOWLY THAN NORMAL WHEN THE AC AND HV SWITCHES ARE OPERATED SIMULTANEOUSLY, SINCE THE SERIES REGULATOR TUBES WILL PASS NO CURRENT UNTIL THEIR FILAMENTS HAVE WARMED UP. EVEN IF THE HV AND AC SWITCHES ARE OPERATED SIMULTANEOUSLY, THE OUTPUT VOLTAGE CANNOT OVERSHOOT, SINCE THE TRANSISTORIZED CONTROL AMPLIFIER IS OPERATIVE AS SOON AS IT IS TURNED ON.

THE POLARITY REVERSING SWITCH SHOULD NOT BE OPERATED WITH THE HIGH-VOLTAGE ON. TO REVERSE POLARITY, THE HV SWITCH SHOULD BE SET TO THE "OFF" POSITION AND THE POLARITY REVERSING SWITCH OPERATED ONLY WHEN THE OUTPUT VOLTAGE HAS FALLEN TO ZERO. FAILURE TO OBSERVE THIS PROCEDURE WILL LEAD TO ARCING IN THE REVERSING SWITCH, WHICH MAY IN TURN, LEAD TO POSSIBLE DAMAGE TO THE POWER SUPPLY.

THE FRONT PANEL METER NORMALLY READS OUTPUT VOLTAGE. BY HOLDING THE METER SWITCH IN THE MA POSITION THE METER MAY BE MADE TO READ THE OUTPUT CURRENT. IT SHOULD BE NOTED THAT THE METER IS OUTSIDE THE REGULATING LOOP AND THUS INTRODUCES A VOLTAGE DROP WHEN IT IS IN THE MA POSITION. THE METER AND ITS ASSOCIATED CIRCUITRY ARE ROUGHLY EQUIVALENT TO AN  $8\Omega$  RESISTOR IN THE OUTPUT LEAD OF THE POWER SUPPLY. TO AVOID POOR LOAD REGULATION DUE TO THIS RESISTANCE, THE METER SWITCH IS SPRING-LOADED SUCH THAT THE METER IS NORMALLY IN THE KV POSITION.

THE POWER SUPPLY IS ADJUSTED AT THE FACTORY TO LIMIT THE CURRENT OUTPUT TO 24 MILLIAMPERES ON MODEL 1544 AND 48 MILLIAMPERES ON MODEL 1547. IF AN OVERLOAD IS APPLIED TO THE OUTPUT TERMINALS, THE OUTPUT VOLTAGE WILL PULSATE FROM ZERO TO A VALUE BELOW THE OUTPUT VOLTAGE SETTING AS INDICATED ON THE OUTPUT VOLTMETER.

THE DUTY CYCLE OF THE PULSATIONS IS CHOSEN TO LIMIT THE INTERNAL DISSIPATION OF THE SERIES REGULATOR TUBES TO A SAFE VALUE EVEN UNDER SHORT CIRCUIT CONDITIONS. WHEN THE RESISTANCE ACROSS THE OUTPUT TERMINALS IS LOW, THE PULSATIONS WILL BE TOO FAST FOR THE METER TO FOLLOW AND THE METER WILL INDICATE SOME VERY LOW STEADY OUTPUT VOLTAGE OR CURRENT.

THE OVERLOAD PROTECTIVE CIRCUIT WILL LIMIT THE AVERAGE CURRENT DELIVERED TO THE LOAD AT SOME AVERAGE VALUE BELOW MAXIMUM RATING WHILE THE ACTION OF THIS OVERLOAD CIRCUIT IS FAST (THE SERIES REGULATOR WILL CUT OFF IN MICROSECONDS ONCE THE OUTPUT CURRENT EXCEEDS THE OVERLOAD LEVEL). IT MUST BE REMEMBERED THAT THE OUTPUT CAPACITOR (1 MFD) WILL DISCHARGE INTO THE LOAD IF THE LOAD

SHORT-CIRCUITS. THE OVERLOAD SYSTEM WILL PROTECT THE LOAD FROM LONG TERM THERMAL DAMAGE DUE TO A CONTINUED SHORT-CIRCUIT. IT IS NOT A CROW-BAR CIRCUIT OF THE TYPE NECESSARY TO PROTECT SUCH LOADS AS ARCING TRAVELING WAVE TUBES, ETC.

#### 4. THEORY OF OPERATION:

THE BASIC SUB-ASSEMBLIES WHICH MAKE UP MODELS 1544 AND 1547 ARE:

- A: AN UNREGULATED DC SOURCE - THIS IS A VOLTAGE DOUBLE CIRCUIT USING SILICON DIODE RECTIFIERS. TAPS ON THE PRIMARY OF THE RECTIFIER TRANSFORMER CHANGED BY THE "SELECTOR SWITCH" WHICH SELECTS 500 VOLT STEPS IN DC OUTPUT VOLTAGE. BY MATCHING THE UNREGULATED TO THE REGULATED VOLTAGE IN THIS WAY THE POWER DISSIPATION IN THE SERIES REGULATOR IS KEPT TO A MINIMUM VALUE, CONSISTENT WITH THE CIRCUIT REQUIREMENTS.
- B: SERIES PASS ELEMENTS - MODEL 1544 EMPLOYES TWO PENTODES CONNECTED IN SERIES, AS A SERIES REGULATOR IN THE POSITIVE LEG OF THE UNREGULATED SUPPLY. MODEL 1547 HAS FOUR PENTODES, CONNECTED IN A SERIES-PARALLEL ARRANGEMENT.
- C: CONTROL AMPLIFIER - A TRANSISTOR AMPLIFIER SENSES A FRACTION OF THE OUTPUT VOLTAGE OBTAINED FROM A SWITCHED RESISTANCE DIVIDER, COMPARES IT TO A FIXED ZENER DIODE VOLTAGE AND PROVIDES DRIVE FOR THE GRID OF THE REGULATOR TUBE.
- D: AUXILIARY POWER SOURCES - THE TRANSISTOR AMPLIFIER AND ZENER DIODE REFERENCE CIRCUIT ARE OPERATED BY THE FOLLOWING AUXILIARY POWER SOURCES:
- (1) -80 VOLT SUPPLY (REFERRED TO THE POSITIVE OUTPUT TERMINAL) THIS SUPPLY IS USED FOR SCREEN GRID BIAS.
  - (2) +50 VOLT, REGULATED SUPPLY (USED TO PROVIDE GRID BIAS FOR THE REGULATOR TUBES AND STABLE VOLTAGE FOR ZENER DIODE CR6).
  - (3) +80 VOLT SUPPLY (REFERRED TO CATHODE OF V2) THIS SUPPLY PROVIDES SCREEN GRID BIAS FOR INPUT REGULATOR TUBE V2 ON MODEL 1544, AND V3 AND V4 ON MODEL 1547.

TRANSFORMER T1 PROVIDES INPUT POWER FOR THE AUXILIARY SUPPLIES AND FILAMENT VOLTAGE FOR THE SERIES REGULATOR TUBES.

THE REGULATED +50 VOLT SUPPLY IS CONTROLLED BY PASS TRANSISTOR Q1, DRIVER STAGE Q3 AND Q4 AND AMPLIFIER STAGE Q5, Q6. THE BASE OF Q6 IS HELD AT A FIXED POTENTIAL BY ZENER DIODE CR6. THE BASE OF Q5 SENSES A FRACTION OF THE 50 VOLT OUTPUT CHOSEN FROM THE RESISTANCE DIVIDER NETWORK R9, R27, R11 BY SETTING VARIABLE RESISTOR R27. THE ACTION OF THE AMPLIFIER AND REGULATOR NETWORK IS TO HOLD THE BASES OF Q5 AND Q6 TO THE SAME POTENTIAL. HENCE, THE VOLTAGE OUTPUT IS HELD WITHIN 5 MILLIVOLTS (FOR A LINE CHANGE OF FROM 105 TO 125 VOLTS) AND THE RIPPLE IN THE OUTPUT LINES IS OF THE ORDER OF 200 MICROVOLTS PEAK-TO-PEAK. R27 ALSO PROVIDES A SMALL RANGE OF ADJUSTMENT OF THE OUTPUT VOLTAGE.

THE NEGATIVE BIAS SUPPLY IS DERIVED FROM A FULL WAVE RECTIFIER (CR3, CR4) WHICH OPERATES INTO A CAPACITIVE INPUT FILTER TO PROVIDE -55 TO -80 VDC DEPEND-



ING ON LINE VOLTAGE.

THE +80 VOLT SUPPLY, DERIVED FROM A SEPARATE WINDING, FULL WAVE RECTIFIER SYSTEM (CR15, CR14) AND A CAPACITIVE FILTER, DEVELOPS +55 TO +80 VDC DEPENDING ON LINE VOLTAGE AND IS USED FOR SCREEN GRID BIAS FOR INPUT REGULATOR TUBES, V1, V2. (CAUTION: DO NOT ATTEMPT TO MEASURE THIS VOLTAGE WITH HV "ON" FROM CHASSIS GROUND. 3000V MAY EXIST BETWEEN THIS SUPPLY AND CHASSIS GROUND. USE AN HV INSULATED METER TO MAKE THIS INTERNAL VOLTAGE MEASUREMENT).

TWO SEPARATE FILAMENT WINDINGS ARE PROVIDED FOR THE SERIES REGULATING TUBES. THEIR FILAMENTS OPERATE AT 6.3 VOLTS.

THE VOLTAGES IDENTIFIED ABOVE SHOULD BE READ WITH THE HV SUPPLY ON AND OPERATING NORMALLY. WITH THE HV SUPPLY OFF, CURRENTS DRAWN FROM THE AUXILIARY SUPPLIES WILL CHANGE AND OUTPUT VOLTAGES MAY CHANGE CORRESPONDINGLY.

IT SHOULD BE NOTED THAT THE VOLTAGE ACROSS ZENER DIODE CR6 IS USED AS THE REFERENCE VOLTAGE FOR THE MAIN HIGH VOLTAGE SUPPLY. SINCE CR6 IS OPERATED FROM THE HIGHLY REGULATED 50 VOLT SUPPLY, ITS ZENER VOLTAGE IS ESSENTIALLY INDEPENDENT OF LINE VOLTAGE VARIATION.

PART OF THE REGULATED SCREEN VOLTAGE FOR THE SERIES REGULATOR TUBES, V1, V2, IS TAKEN FROM A HALF WAVE VOLTAGE DOUBLER THROUGH R88 AND CR45 (20V ZENER DIODE).

ONE ZENER DIODE (CR5) IS RUN FROM THE POSITIVE SUPPLY; ANOTHER ZENER DIODE (CR9) IS RUN FROM THE NEGATIVE SUPPLY. THESE TWO ZENER DIODES PROVIDE A HIGHLY STABILIZED VOLTAGE SOURCE FROM WHICH THE OPERATING POTENTIALS OF THE CONTROL AMPLIFIER ARE DERIVED.

4.1 REGULATOR ACTION: THE OUTPUT VOLTAGE IS SENSED BY A RESISTIVE DIVIDER WHOSE LOW END IS MADE UP OF THE RESISTOR R38, R18, R39 AND R40. THE HIGH VOLTAGE END IS MADE UP OF R64, THE SWITCHED RESISTOR CHAIN R51 THROUGH R63 AND POTENTIOMETER R50. THIS DIVIDER CHAIN IS OF THE SUMMING JUNCTION TYPE WITH THE HIGH END CONNECTED TO REFERENCE ZENER CR6 AND THE LOW VOLTAGE END CONNECTED TO THE NEGATIVE TERMINALS OF THE REGULATED SUPPLY. THE OUTPUT OF THE DIVIDER IS FED TO ONE BASE OF DIFFERENTIAL TRANSISTOR Q11. THE OTHER BASE OF THIS TRANSISTOR IS CONNECTED TO THE POSITIVE OUTPUT OF THE REGULATED SUPPLY. THE HIGH VOLTAGE END OF THE DIVIDER IS SHUNTED BY A CAPACITOR, C5A WHICH, BY INCREASING THE AC RESPONSE OF THE FEEDBACK LOOP, HOLDS THE RIPPLE TO A MINIMUM VALUE. Q11 IS FOLLOWED BY A TRANSISTOR AMPLIFIER, Q9 AND Q10, WHICH IS FOLLOWED, IN TURN, BY DRIVER STAGE Q8. THIS DRIVER STAGE IS ABLE TO DRIVE THE GRID OF THE PASS TUBE FROM ZERO TO -65 VOLTS WITH RESPECT TO CATHODE, PROVIDING AMPLE SWING FOR ALL OPERATING CONDITIONS.

ALTHOUGH THE NUMBER OF AMPLIFIER STAGES USED IS MODEST IT SHOULD BE NOTED THAT THE DRIVER STAGE PROVIDES A VOLTAGE GAIN IN EXCESS OF 1000 BECAUSE THE TRANSISTOR IN THIS STAGE IS WORKING INTO AN EXTREMELY HIGH RESISTANCE LOAD. ALSO, BY DRIVING THE GRID OF THE SERIES REGULATOR TUBE DIRECTLY FROM A VOLTAGE, REFERENCED TO THE TUBE CATHODE, FULL ADVANTAGE IS TAKEN OF THE VOLTAGE GAIN OF THE PASS TUBE ITSELF.

4.2 CURRENT LIMITER: THE LOAD CURRENT DRAWN FROM THE POWER SUPPLY IS DETECTED BY THE SERIES RESISTANCE OF R5 AND R37, ONE END OF WHICH IS CONNECTED TO THE EMITTER OF TRANSISTOR Q7. THE BASE OF Q7 IS CONNECTED TO A POSITIVE VOLTAGE, DERIVED FROM THE REGULATED 50 VOLT SUPPLY THROUGH THE RESISTOR CHAIN R3, R4, AND R6. AT LOW LOAD CURRENTS Q7 IS HEAVILY BACK BIASED AND HAS NO EFFECT ON THE OPERATION OF THE REGULATOR. AS THE LOAD CURRENT INCREASES, A POINT WILL BE REACHED WHERE Q7 STARTS TO CONDUCT. THE COLLECTOR CURRENT OF Q7 PASSES THROUGH THE COLLECTOR LOAD OF Q9 IN SUCH A WAY THAT THE GRID OF THE SERIES TUBE IS DRIVEN NEGATIVE. Q7 THEN WILL LIMIT THE OUTPUT CURRENT OF THE POWER SUPPLY TO A VALUE (IN THE NEIGHBORHOOD OF 24 MILLIAMPERES IN MODEL 1544, 48 MILLIAMPERES IN MODEL 1547) WHERE THE DROP ACROSS R5 AND R37 IS JUST SUFFICIENT TO TURN Q7 ON.

THIS ARRANGEMENT, WHILE SUFFICIENT TO PROVIDE CURRENT LIMITING, IS NOT ENOUGH TO PROTECT THE POWER SUPPLY FROM DAMAGE UNDER CONDITIONS OF SUSTAINED OVERLOAD. IF A SHORT CIRCUIT IS APPLIED TO THE OUTPUT WITH THE POWER SUPPLY SET FOR A HIGH OUTPUT VOLTAGE, THE POWER DISSIPATION IN THE SERIES REGULATOR TUBE WOULD EXCEED THE RATED VALUE. IN ORDER TO HOLD THE PASS TUBE DISSIPATION WITHIN ACCEPTABLE LIMITS, IT IS NECESSARY TO REDUCE THE OUTPUT CURRENT (UNDER OVERLOAD CONDITIONS) AS THE LOAD RESISTANCE IS REDUCED.

\*THE TRANSISTOR Q2 PERFORMS THIS FUNCTION. WHEN THE POWER SUPPLY IS REGULATING NORMALLY THE BASE OF THIS TRANSISTOR IS AT A POTENTIAL VERY CLOSE TO THAT OF ITS EMITTER AND THE TRANSISTOR WILL PASS NO CURRENT. WHEN THE OUTPUT CURRENT INCREASES TO THE POINT WHERE THE CURRENT LIMITING TRANSISTOR Q7 STARTS TO CONDUCT, THE OUTPUT OF THE VOLTAGE DIVIDER, AND HENCE THE BASE OF Q2, WILL GO POSITIVE. Q2 WILL CONDUCT, REDUCING THE VOLTAGE AT THE JUNCTION OF RESISTORS R3 AND R4. SINCE THIS IS THE VOLTAGE AGAINST WHICH Q7 BALANCES THE LOAD CURRENT, Q7 WILL REDUCE THE LOAD CURRENT UNTIL THE SYSTEM IS AGAIN IN BALANCE. IT IS OBVIOUS, THEREFORE, THAT ONCE AN OVERLOAD CONDITION HAS BEEN REACHED, THE LOAD CURRENT WILL DROP WITH A FURTHER DECREASE IN LOAD RESISTANCE. THE MAGNITUDE OF THIS DROP HAS BEEN SET SO THAT THE POWER DISSIPATION OF THE SERIES REGULATOR TUBES IS ALWAYS WITHIN THE RATED LIMITS.

IF THE OVERLOAD SYSTEM IS ALLOWED TO OPERATE AS A PURELY DC SYSTEM AS DESCRIBED ABOVE, IT MAY SHOW A TENDENCY TO LOCK UP ON TURN-ON OR REMOVAL OF OVERLOADS OR SHORT CIRCUITS. TO AVOID THE NEED FOR ELABORATE BALANCING, THE CAPACITOR C13 HAS BEEN INCLUDED. THIS INCREASES THE AC GAIN OF THE OVERLOAD SYSTEM TO THE POINT WHERE IT IS UNSTABLE, SO THAT WHEN AN OVERLOAD IS APPLIED TO THE SUPPLY, THE CURRENT LIMITING CIRCUIT PULSES. THE OUTPUT WILL RISE TO THE LIMITING VALUE, KICK DOWN TO A LOW LIMITING VALUE (WHICH MAY BE AS LOW AS 1 MILLIAMPERE) FOR A TIME WHICH DEPENDS ON THE SEVERITY OF THE OVERLOAD, AND THEN RISE TOWARD MAXIMUM LIMITING VALUE TO REPEAT THE CYCLE. THE FREQUENCY OF PULSATION INCREASES AS THE RESISTANCE OF THE LOAD IS DECREASED.

UNDER MOST OVERLOAD CONDITIONS THE PRESENCE OF AN OVERLOAD WILL BE SIGNALLED BY A PULSATION OF THE OUTPUT VOLTAGE METER. UNDER SHORT CIRCUIT CONDITIONS OR SEVERE OVERLOAD, THE RATE OF PULSATION MAY BE TOO HIGH FOR THE METER TO FOLLOW, SO THAT SOME LOW, AVERAGE VOLTAGE WILL BE READ.

PULSATION OF THE METER, OR A METER READING WHICH IS SUBSTANTIALLY LOWER THAN THE SETTINGS OF THE VOLTAGE SELECTOR SWITCHES IS AN INDICATION THAT THE POWER SUPPLY IS OVERLOADED.

WHEN THE EXTERNAL CAPACITANCE EXCEEDS 10 MF THE TIME CONSTANT OF THE OVERLOAD CIRCUIT MAY BE ALTERED TO THE POINT WHERE THE POWER SUPPLY FAILS TO TURN ON UNDER CERTAIN CONDITIONS AND LOCKS UP INSTEAD AT A VOLTAGE LOWER THAN THAT SET ON THE VOLTAGE SELECTOR SWITCHES. THEREFORE, EXCESSIVE CAPACITANCE IN PARALLEL WITH THE OUTPUT LOAD, SHOULD BE AVOIDED. IT IS POSSIBLE TO MODIFY THE SUPPLY SO THAT IT WILL OPERATE SATISFACTORILY AND THE FACTORY SHOULD BE CONSULTED IF OPERATION WITH LARGE CAPACITANCES ACROSS THE OUTPUT IS CONTEMPLATED.

4.3 PROTECTION CIRCUITS: IN POWER SUPPLIES WHICH USE TUBE AMPLIFIERS, NO MAJOR PRECAUTIONS ARE NECESSARY TO INSURE THAT VOLTAGE TRANSIENTS DO NOT AFFECT THE AMPLIFIER. TUBES WILL SURVIVE MOMENTARY OVER-VOLTAGES OF CONSIDERABLE AMPLITUDE WITHOUT APPARENT DAMAGE. SEMICONDUCTORS, ON THE OTHER HAND, ARE HIGHLY SUSCEPTIBLE TO VOLTAGE DAMAGE, AND THE AMPLIFIER COMPONENTS MUST BE PROTECTED AGAINST ALL POSSIBLE TRANSIENTS. SPECIFIC PROTECTION HAS BEEN PROVIDED AGAINST THE FOLLOWING CONTINGENCIES:

4.3.1 SHORTED OUTPUT: IF THE OUTPUT TERMINALS OF THE SUPPLY ARE SHORTED AT HIGH VOLTAGE, FEEDBACK CAPACITOR C5A MUST DISCHARGE. IN THE ABSENCE OF A SPECIFIC PROTECTION CIRCUIT, CURRENT FROM THE POSITIVE TERMINAL OF THIS CAPACITOR WILL FLOW THROUGH THE FORWARD BIASED BASE JUNCTION OF Q11. THIS WILL APPLY A HIGH VOLTAGE TO THE REVERSE-BIASED BASE JUNCTION OF THIS TRANSISTOR PRODUCING A ZENER BREAKDOWN TO GROUND. SINCE A GOOD DEAL OF ENERGY IS STORED IN C5A WHEN IT IS CHARGED TO THE FULL OUTPUT VOLTAGE, THIS PROCESS WILL DESTROY Q11, AND IS LIKELY TO FUSE JUNCTIONS IN OTHER TRANSISTORS IN THE AMPLIFIER.

TO AVOID THE POSSIBILITY OF CHAIN BURN-OUT, THE DIODES CR8 AND CR7 HAVE BEEN ADDED. THESE PROVIDE A DIRECT DISCHARGE PATH TO THE POSITIVE REGULATED OUTPUT TERMINAL. THE CURRENT THROUGH THESE DIODES IS LIMITED BY THE RESISTOR R19 CONNECTED IN SERIES WITH C5A. DURING A HEAVY DISCHARGE THROUGH CR8 AND CR7 THE VOLTAGE AT THE ANODE OF CR8 MAY RISE AS HIGH AS 10 VOLTS; THE RESISTOR R26 IS CONNECTED IN SERIES WITH THE BASE OF Q11 TO LIMIT THE CURRENT THAT CAN PASS THROUGH THE Q11 BASE JUNCTION UNDER THIS CONDITION. THIS THIS PROTECTIVE CIRCUIT, IT HAS BEEN FOUND THAT THE OUTPUT TERMINALS CAN BE SHORTED REPEATEDLY AT FULL OUTPUT VOLTAGE WITHOUT DAMAGE TO THE SEMICONDUCTORS IN THE AMPLIFIER.

4.3.2 REGULATOR TUBE ARCING: A VACUUM TUBE RUN AT HIGH ELECTRODE POTENTIALS IS ALWAYS SUSCEPTIBLE TO ARCING, ESPECIALLY WHEN NEAR THE END OF ITS USEFUL LIFE. WITHOUT PROTECTIVE CIRCUITRY ARCING IN THE SERIES REGULATOR TUBE WOULD HAVE A DISASTROUS EFFECT ON THE SEMICONDUCTOR AMPLIFIER.

4.3.2.1 PLATE CATHODE ARCS: THE MAIN EFFECT OF A PLATE TO CATHODE ARC IN THE SERIES REGULATOR TUBE IS THAT A HEAVY CURRENT WILL PASS THROUGH RESISTORS R5 AND R37. THIS WILL DEVELOP A MOMENTARY HIGH VOLTAGE ACROSS THESE RESISTORS. WITHOUT PROTECTION, A HIGH VOLTAGE ACROSS R5 AND R37 WILL DESTROY TRANSISTORS Q7 THROUGH Q11. TO GUARD AGAINST THIS CONTINGENCY, SEVERAL STEPS HAVE BEEN TAKEN.\*

INDUCTOR L1 (L1 AND L2 IN MODEL 1547) HAS BEEN ADDED TO LIMIT THE PEAK CURRENT THAT CAN BE DRAWN FROM FILTER CAPACITORS C10A AND C10B (C10 AND C11 ON MODEL 1547).

THE VOLTAGE DEVELOPED ACROSS R5 AND R37 HAS BEEN HELD TO 100 VOLTS PEAK BY CONNECTING A NEON GLOW DISCHARGE TUBE ACROSS THESE RESISTORS.

RESISTOR R66 HAS BEEN CONNECTED IN THE COLLECTOR OF Q7 TO LIMIT THE PEAK CURRENT THAT CAN BE DRAWN THROUGH Q7 UNDER THIS CONDITION. DIODE CR12 LIMITS THE VOLTAGE EXCURSION TO TRANSISTORS Q8 THRU Q11. WITH THESE PRECAUTIONS, IT IS FOUND THAT THE ANODE OF THE SERIES REGULATOR TUBE CAN BE SHORTED TO THE FILAMENT, EVEN WITH THE SUPPLY SET FOR FULL OUTPUT AND THE OUTPUT TERMINALS SHORTED, WITHOUT DAMAGE TO THE UNIT.

4.3.2.2 PLATE SCREEN ARCS: AN ARC OF THIS SORT WOULD PRODUCE A HIGH POTENTIAL BETWEEN SCREEN AND CATHODE TENDING TO DESTROY THE CAPACITORS C15 AND C22 AND COMPONENTS IN THE REGULATED +50 VOLT SUPPLY. THIS POSSIBILITY IS AVOIDED BY CLAMPING THE VOLTAGE AT C15 AND C22 BY SIMILAR MEANS AS IN PARAGRAPH 4.3.2.1. THE CURRENT WHICH CAN BE FED BACK INTO THE +50 VOLT SUPPLY IS LIMITED BY R70.

4.3.2.3 PLATE GRID ARCS: AN ARC OF THIS SORT WOULD, WITHOUT PROTECTION, TEND TO DESTROY THE DRIVER TRANSISTOR Q8. AS A PROTECTIVE MEASURE, THE GRID IS CLAMPED BY DIODE CR13 SO THAT IT CANNOT MOVE MORE THAN A FEW VOLTS POSITIVE WITH RESPECT TO THE CATHODE. RESISTOR R35 LIMITS THE PEAK CURRENT THROUGH CR13 TO A SAFE VALUE.

4.3.2.4 SUDDEN VOLTAGE REDUCTION: IF THE OUTPUT VOLTAGE SETTING IS SUDDENLY REDUCED TO ZERO. CAPACITOR C5B WILL BE ALMOST SHORT-CIRCUITED. THE RESULTANT HEAVY CURRENT IS LIKELY TO DAMAGE DIODE CR11 AND CAUSE ARCING AND POSSIBLY WELDING OF THE CONTACTS OF THE SELECTOR SWITCHES. TO AVOID THIS POSSIBILITY, RESISTOR R64 HAS BEEN INCLUDED IN SERIES WITH THE SELECTOR RESISTORS. R64 IS ALWAYS IN SERIES WITH C5B ON DISCHARGE AND LIMITS THE DISCHARGE CURRENT TO A SAFE VALUE. THE INCLUSION OF RESISTOR R64 MEANS

THAT THE LOWER LIMIT TO WHICH THE OUTPUT VOLTAGE CAN BE SET IS 1 VOLT.

WITH THE PRECAUTIONS DESCRIBED ABOVE, THE POWER SUPPLY IS EFFECTIVELY PROTECTED AGAINST ALL TRANSIENTS WHICH CAN OCCUR AND IT HAS BEEN FOUND THAT EVEN ABUSE OF THE POWER SUPPLY WILL NOT LEAD TO TRANSISTOR DAMAGE.

4.4 VOLTAGE SELECTION: THE REGULATOR OPERATES TO HOLD A CONSTANT CURRENT THROUGH THE VOLTAGE DIVIDER. THE OUTPUT VOLTAGE MAY THEREFORE BE VARIED LINEARLY BY CHANGING THE VALUE OF THE HIGH-VOLTAGE RESISTOR IN THE DIVIDER. THIS RESISTOR MAY BE SWITCHED IN DECADE STEPS BY MEANS OF THE THREE SWITCHES, S1 THROUGH S3. FINE ADJUSTMENTS ARE MADE BY MEANS OF POTENTIOMETER R50. SWITCH S1, WHICH PROVIDES 500 VOLTS STEPS, ALSO SWITCHES TAPS ON THE PRIMARY OF THE MAIN RECTIFIER TRANSFORMER TO KEEP THE POWER DISSIPATION IN THE SERIES TUBES AT A MINIMUM VALUE CONSISTENT WITH ADEQUATE REGULATION.

4.5 METERING: WITH THE METER SWITCH IN ITS NORMAL POSITION, THE FRONT PANEL METER READS THE OUTPUT VOLTAGE OF THE POWER SUPPLY. WHEN THIS SWITCH IS HELD IN THE MA POSITION, THE METER READS THE OUTPUT CURRENT IN MILLAMPERES.

THE METER IS OUTSIDE THE FEEDBACK LOOP AND THUS INTRODUCES A RESISTANCE OF APPROXIMATELY  $8 \Omega$  ( $5 \Omega$  IN MODEL 1547) IN SERIES WITH THE OUTPUT LEADS WHEN IT IS CONNECTED IN THE CURRENT POSITION. THE SPRINGLOADED METER SWITCH INSURES THAT THE METER IS NORMALLY IN THE KV POSITION WHERE IT HAS NO EFFECT ON THE OUTPUT VOLTAGE REGULATION.

THE METER IS WIRED INTO THE CIRCUIT THROUGH THE POLARITY REVERSING SWITCH. THE CONNECTIONS ARE SO ARRANGED THAT THE POLARITY OF THE METER IS SWITCHED AT THE SAME TIME AS THE POLARITY OF THE OUTPUT VOLTAGE. THUS, THE METER READING IS ALWAYS THE SAME DIRECTION IN BOTH THE KV AND MA POSITIONS AND IS EFFECTIVELY ALWAYS AT GROUND POTENTIAL FOR BOTH POSITIONS OF THE POLARITY SWITCH.

## 5. OPERATING ADJUSTMENTS:

5.1 REFERENCE CURRENT: REFERENCE DIODE CR6 HAS A TEMPERATURE COEFFICIENT OF VOLTAGE OF .001% PER °C MAXIMUM. THIS FIGURE HOLDS ONLY WHEN THE DIODE IS OPERATED AT ITS RATED CURRENT OF 10.0 MILLIAMPERES. POTENTIOMETER R27 IS INCLUDED TO ALLOW THIS CURRENT TO BE CORRECTLY SET. THIS ALLOWS THE VOLTAGE OF THE 50 VOLT SUPPLY, AND THUS THE ZENER CURRENT, TO BE VARIED OVER A SMALL RANGE. THIS CONTROL SHOULD BE READJUSTED WHENEVER THE REFERENCE DIODE IS REPLACED OR AFTER REPLACEMENT OF ANY COMPONENT IN THE 50 VOLT SUPPLY.

TO MAKE THE ADJUSTMENT, THE POWER SUPPLY SHOULD BE SET FOR NEGATIVE OUTPUT. THIS WILL BRING THE CIRCUIT BOARD CLOSE TO GROUND POTENTIAL.

CONNECT A VOLTMETER (RESISTANCE IS  $500K \Omega$  OR GREATER) ACROSS THE RESISTOR R17.

SET THE OUTPUT FOR SOME CONVENIENT LOW VALUE AND TURN ON THE SUPPLY.

WAIT TEN MINUTES OR MORE FOR COMPONENTS TO REACH OPERATING TEMPERATURE AND THEN ADJUST R27 UNTIL THE VOLTAGE DROP ACROSS R17 IS 24.97 VDC  $\pm 1\%$ . THE TRIMPOT SHOULD THEN BE SEALED WITH A DROP OF GLYPTAL OR SOME CONVENIENT ADHESIVE.

IT SHOULD BE NOTED THAT THIS ADJUSTMENT MUST BE PERFORMED WITH THE MAIN HIGH VOLTAGE SUPPLY OPERATING NORMALLY TO INSURE THAT THE CURRENT THROUGH THE DIVIDER CHAIN (WHICH IS INCLUDED IN THE CURRENT FLOWING THROUGH R17) IS AT ITS NORMAL VALUE. THIS WILL HOLD TRUE EVEN AT 1 VOLT OUTPUT.

- 5.2 OUTPUT VOLTAGE CALIBRATION: THE VOLTAGE OF THE REFERENCE DIODE CR6 IS SPECIFIED AT 25 VOLTS  $\pm 5\%$ . TWO RESISTORS R39 AND R40 AND POTENTIOMETER R38 ARE PROVIDED SO THAT THE OUTPUT VOLTAGE CAN BE SET CORRECTLY FOR VARIATIONS IN REFERENCE VOLTAGE FROM DIODE TO DIODE. TWO RESISTORS AND A POTENTIOMETER ARE USED, RATHER THAN A SINGLE POTENTIOMETER OF LARGER VALUE, SINCE THIS IS A CRITICAL POINT IN THE CIRCUIT FROM THE POINT OF VIEW OF STABILITY AND IT IS DESIRABLE TO KEEP THE NOISE INTRODUCED BY THE POTENTIOMETER CONTACT ARM TO A MINIMUM

THE CALIBRATION OF THE UNIT SHOULD BE CHECKED AT REGULAR INTERVALS OF APPROXIMATELY SIX MONTHS AND THE POTENTIOMETER R38 READJUSTED. IF NECESSARY, TO BRING THE UNIT BACK WITHIN SPECIFICATIONS. SIMILAR READJUSTMENT MAY BE NECESSARY IF ANY COMPONENT IN THE REGULATOR SECTION IS REPLACED.

IF THE ZENER REFERENCE DIODE IS REPLACED, HOWEVER, THE FULL CALIBRATION PROCEDURE MAY BE NECESSARY. THIS IS DONE AS FOLLOWS:

REMOVE HV FUSE, F2 ON FRONT PANEL. SET THE POWER SUPPLY FOR NEGATIVE POLARITY.

CONNECT A VOLTMETER (RESISTANCE 500K $\Omega$  OR GREATER) ACROSS RESISTOR R17. PLACE AN EXTERNAL JUMPER FROM CHASSIS TO THE JUNCTION OF R40, CR8 AND CR11. THIS SETS THE OUTPUT PROGRAMMING FOR ZERO VOLTS. NO DANGEROUS HIGH VOLTAGE WILL BE REQUIRED TO CALIBRATE INITIALLY.

TURN ON (S6) "AC ON" SWITCH ALLOWING TEN MINUTE WARM-UP PERIOD BEFORE ANY MEASUREMENTS ARE TAKEN. ADJUST R27 UNTIL THE VOLTAGE DROP ACROSS R17 IS 24.97 VDC  $\pm 1\%$ . THE TRIMPOT SHOULD BE SEALED WITH GLYPTAL, ETC.

REMOVE THE VOLTMETER FROM R17 AND PLACE IT ACROSS R18 (18.8K). SET THE VOLTAGE ACROSS R18 TO 23.50V  $\pm 0.1\%$  BY ADJUSTING R38. IF NECESSARY PLACE A JUMPER ACROSS R39 AND R40 OR JUST ACROSS R39 TO SET THE VOLTAGE ACROSS R18 TO THE CORRECT VALUE (R38 AT CENTER POSITION). JUMPERS WHICH MAY ALREADY BE PRESENT ON THE BOARD SHOULD BE REMOVED BEFORE THE JUMPERS DESCRIBED ABOVE ARE INSTALLED. TURN THE POWER OFF.

REMOVE EXTERNAL JUMPER (CHASSIS AND JUNCTION OF R40 AND CR8 ANODE). REPLACE HV FUSE F2. A VOLTMETER SHOULD BE CONNECTED TO THE OUTPUT TERMINALS OF THE POWER SUPPLY. THE SELECTOR SWITCHES SHOULD BE SET FOR AN OUTPUT VOLTAGE OF 3001 VOLTS. THE UNIT SHOULD BE TURNED ON AND ALLOWED TO STABILIZE FOR AT LEAST FIVE MINUTES. THE POTENTIOMETER R38 SHOULD BE READJUSTED, WITH AN INSULATED SCREWDRIVER, UNTIL THE OUTPUT VOLTAGES AS READ ON THE EXTERNAL VOLTMETER, AGREE WITH THE SELECTOR SWITCH SETTINGS. THE UNIT SHOULD NOW BE IN CALIBRATION FOR ALL OUTPUT SETTINGS.

5.3 LOAD REGULATION: THE LOAD REGULATION OF THE POWER SUPPLY CAN BE ADJUSTED OVER A SMALL RANGE BY MEANS OF THE POTENTIOMETER R21. SINCE THE VOLTAGE DEVELOPED ACROSS R5 TO R37 IS PROPORTIONAL TO THE LOAD CURRENT, A FRACTION OF THIS VOLTAGE CAN BE APPLIED TO THE COLLECTOR OF Q11. VARYING THE VALUE OF R21 VARIES THIS FRACTION AND THUS CORRECTS FOR LOAD REGULATION OF THE SUPPLY. THIS ADJUSTMENT SHOULD BE MADE AT AN OUTPUT VOLTAGE OVER 2000 VOLTS.

5.4 LINE REGULATION: A SMALL RANGE OF ADJUSTMENT OF LINE REGULATION IS PROVIDED BY THE POTENTIOMETER R65. THE OUTPUT VOLTAGE OF THE -70 VOLT AUXILIARY SUPPLY MOVES WITH THE LINE VOLTAGE. A FRACTION OF THIS VOLTAGE IS FED TO THE COLLECTOR OF Q11 AND THIS FRACTION IS CONTROLLED BY THE SETTING OF R65.

THE UNIT HAS BEEN ADJUSTED FOR OPTIMUM REGULATION BEFORE LEAVING THE FACTORY. FOR SOME APPLICATIONS NEGATIVE LINE REGULATION MAY BE DESIRABLE (TO OFFSET LINE REGULATION IN SOME OTHER PART OF THE SYSTEM FOR INSTANCE) AND THIS CAN BE PROVIDED BY ADJUSTING R65.

5.5 CURRENT LIMITING: THE CURRENT AT WHICH THE LIMITING ACTION BEGINS MAY BE ADJUSTED OVER A 25% RANGE BY MEANS OF THE POTENTIOMETER R5 WHICH VARIES THE BIAS APPLIED TO THE BASE OF THE LIMITING TRANSISTOR Q7.

THE POWER SUPPLY IS ADJUSTED AT THE FACTORY TO LIMIT AT 24 MILLIAMPERES ON MODEL 1544 AND 48 MILLIAMPERES ON MODEL 1547. THE UNIT MAY BE SET TO LIMIT AT A LOWER CURRENT IF THIS IS DESIRED, BUT HIGHER SETTINGS ARE NOT RECOMMENDED SINCE THEY MAY LEAD TO OVERHEATING OF THE SERIES REGULATOR TUBES UNDER SOME CONDITIONS OF LINE VOLTAGE AND OUTPUT VOLTAGE SETTINGS.

5.6 METER:

5.6.1 KILOVOLT SCALE: THE CALIBRATION OF THE KILOVOLT SCALE IS ADJUSTED BY MEANS OF THE POTENTIOMETER R45. THE UNIT IS SET TO A GIVEN OUTPUT VOLTAGE (READ EITHER ON THE SELECTOR SWITCHES OR ON AN EXTERNAL VOLTMETER) AND R45 IS TURNED UNTIL THE METER READING CORRESPONDS WITH THE ACTUAL OUTPUT VOLTAGE. THIS SETTING IS BEST MADE AT A VOLTAGE ABOUT 2000 VOLTS.

5.6.2 MILLIAMPERE SCALE: THE CALIBRATION OF THIS SCALE IS ADJUSTED BY MEANS OF THE POTENTIOMETER R43. TO SET THE METER, THE POWER SUPPLY IS TURNED ON WITH AN EXTERNAL LOAD AND AN EXTERNAL METER MEASURING THE CURRENT SUPPLIED TO THIS LOAD. R43 IS ADJUSTED UNTIL THE FRONT PANEL METER READING AGREES WITH THAT OF THE EXTERNAL CURRENT METER. THIS ADJUSTMENT IS BEST MADE AT

A CURRENT LEVEL ABOUT 15 MILLIAMPERES ON MODEL 1544  
AND ABOUT 30 MILLIAMPERES ON MODEL 1547.

6. CAUTION:

IN SERVICING THIS POWER SUPPLY AND IN MAKING ADJUSTMENTS, IT MUST BE REMEMBERED THAT LETHAL VOLTAGES EXIST AT MANY POINTS WHEN THE UNIT IS OPERATING. IN PARTICULAR, THE TRANSISTOR CIRCUIT BOARDS FLOAT AT THE POTENTIAL OF THE POSITIVE OUTPUT TERMINAL AND HENCE MAY BE AT A POTENTIAL OF 3000 VOLTS WITH RESPECT TO GROUND.

EVEN WHEN THE UNIT IS TURNED OFF, THERE ARE LARGE CAPACITORS IN THE UNIT WHICH MAY HOLD CHARGE FOR AN APPRECIABLE LENGTH OF TIME. NO ATTEMPT AT SERVICING SHOULD BE MADE UNTIL ALL HIGH VOLTAGE CAPACITORS HAVE BEEN GROUNDED. ALL SAFETY PRECAUTIONS NORMALLY USED ON HIGH-VOLTAGE EQUIPMENT MUST BE OBSERVED ON THIS UNIT.

WHEREVER POSSIBLE, SERVICING SHOULD BE CARRIED OUT WITH THE POWER SUPPLY SET FOR NEGATIVE OUTPUT POLARITY SINCE IN THIS CONDITION THE TRANSISTOR CIRCUIT BOARDS ARE CLOSE TO GROUND POTENTIAL.

TRIMPOTS ON THE CIRCUIT BOARDS SHOULD BE ADJUSTED WITH AN INSULATED SCREWDRIVER, PARTLY FOR THE PROTECTION OF THE OPERATOR AND PARTLY TO INSURE THAT COMPONENTS ON THE BOARD ARE NOT DAMAGED BY ACCIDENTAL SHORT CIRCUITS.



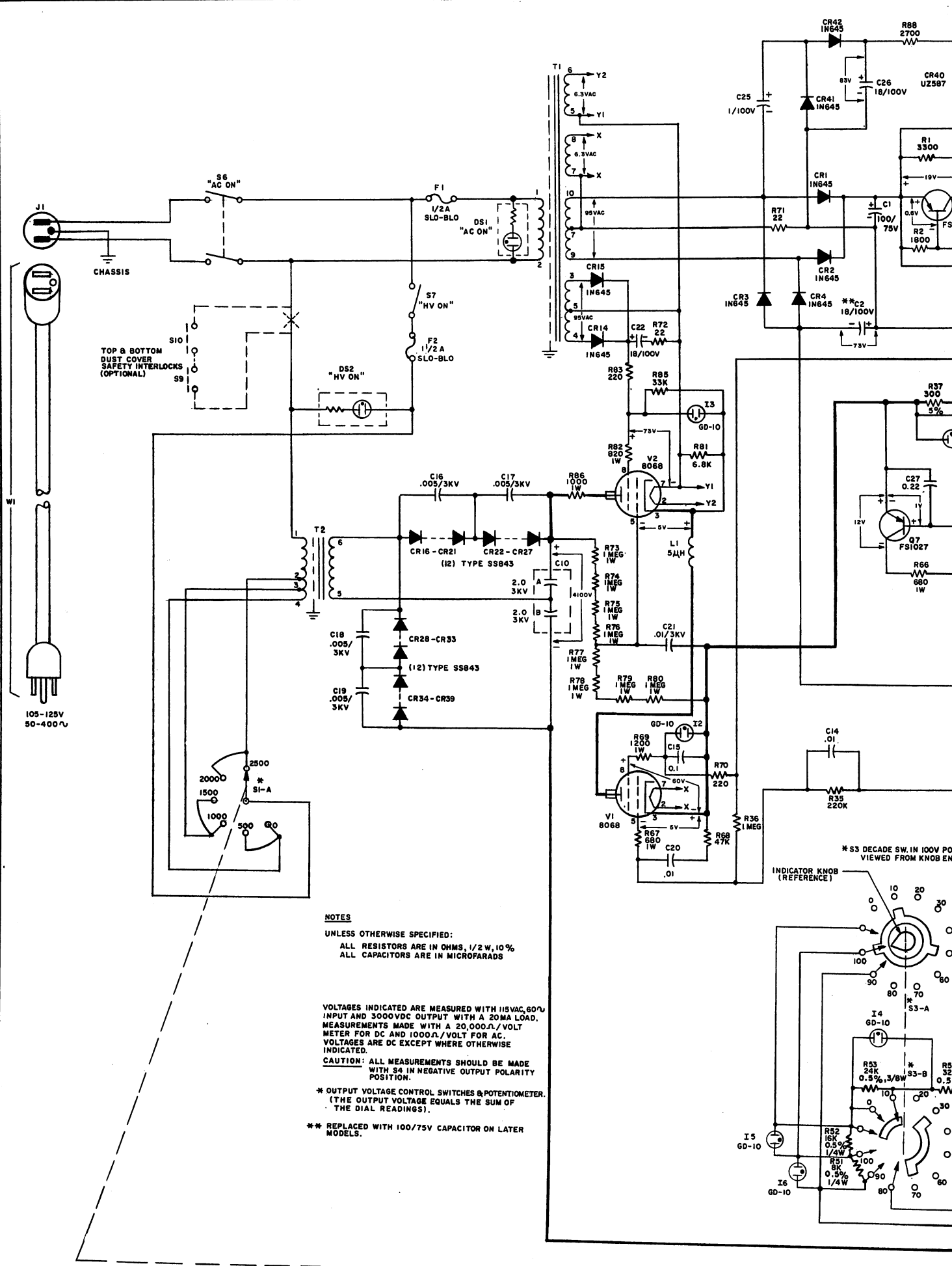

TOP & BOTTOM  
DUST COVER  
SAFETY INTERLOCKS  
(OPTIONAL)

105-125V  
50-400V

**NOTES**

UNLESS OTHERWISE SPECIFIED:  
ALL RESISTORS ARE IN OHMS, 1/2 W, 10%  
ALL CAPACITORS ARE IN MICROFARADS

VOLTAGES INDICATED ARE MEASURED WITH 115VAC, 60<sup>Hz</sup>  
INPUT AND 3000VDC OUTPUT WITH A 20MA LOAD.  
MEASUREMENTS MADE WITH A 20,000 $\Omega$ /VOLT  
METER FOR DC AND 1000 $\Omega$ /VOLT FOR AC.  
VOLTAGES ARE DC EXCEPT WHERE OTHERWISE  
INDICATED.

**CAUTION:** ALL MEASUREMENTS SHOULD BE MADE  
WITH S4 IN NEGATIVE OUTPUT POLARITY  
POSITION.

\* OUTPUT VOLTAGE CONTROL SWITCHES & POTENTIOMETER.  
(THE OUTPUT VOLTAGE EQUALS THE SUM OF  
THE DIAL READINGS).

\*\* REPLACED WITH 100/75V CAPACITOR ON LATER  
MODELS.

\* S3 DECADE SW. IN 100V POS  
VIEWED FROM KNOB END

INDICATOR KNOB  
(REFERENCE)

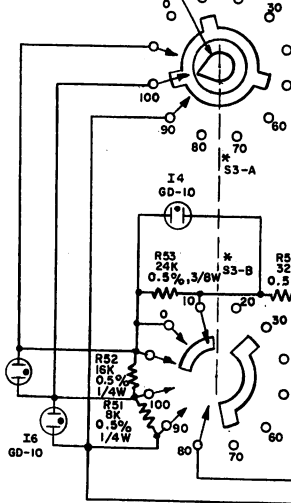

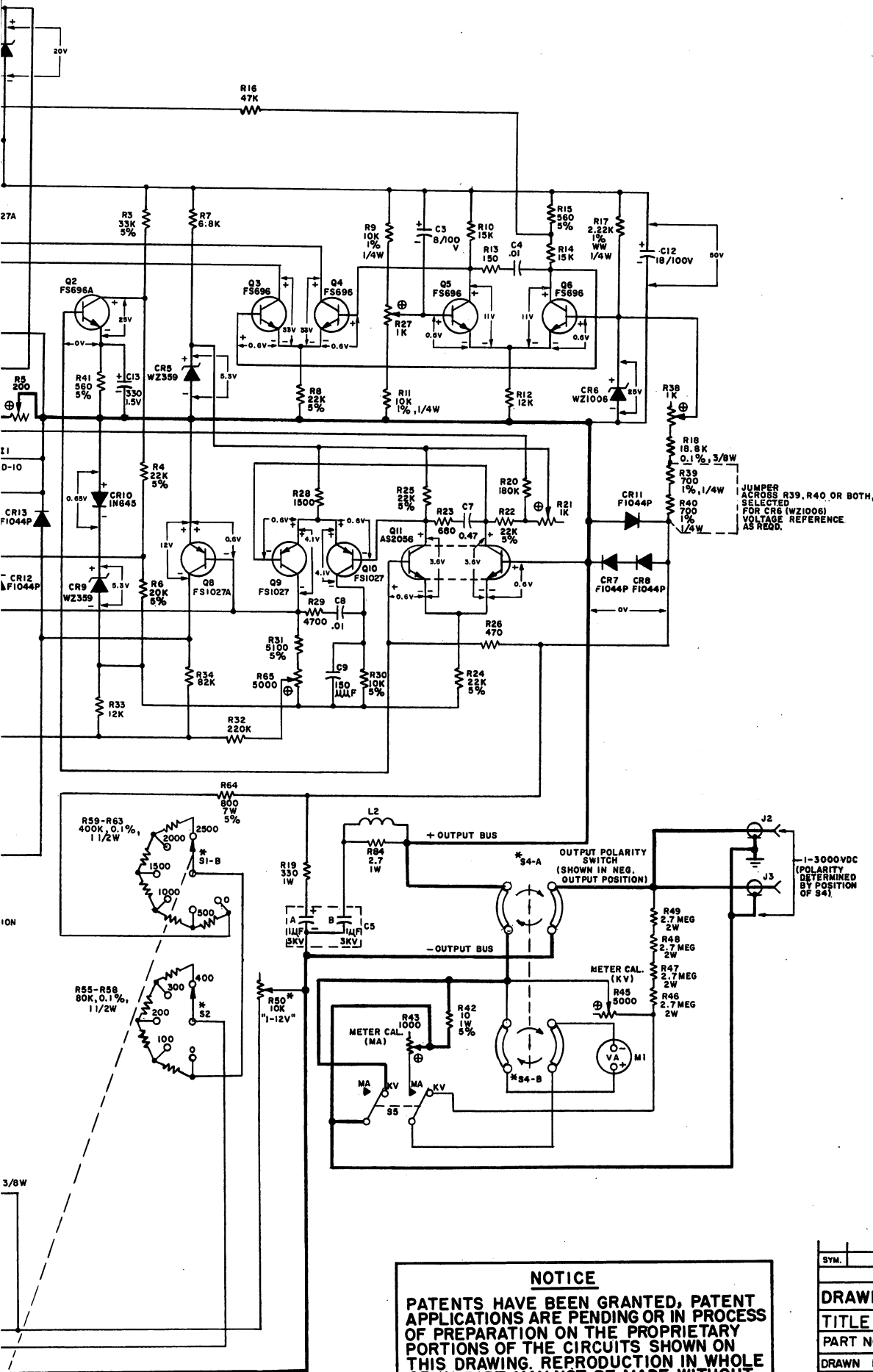

JUMPER  
ACROSS R39, R40 OR BOTH,  
SELECTED  
FOR CR6 (WZ1006)  
VOLTAGE REFERENCE  
AS REQD.

-1-3000VDC  
(POLARITY  
DETERMINED  
BY POSITION  
OF S4)

**NOTICE**

PATENTS HAVE BEEN GRANTED, PATENT APPLICATIONS ARE PENDING OR IN PROCESS OF PREPARATION ON THE PROPRIETARY PORTIONS OF THE CIRCUITS SHOWN ON THIS DRAWING. REPRODUCTION IN WHOLE OR IN PART MAY NOT BE MADE WITHOUT PERMISSION.

SYM.	DESCRIPTION	APPD.	DATE
REVISIONS			
DRAWING NO. PS-1544-18			REV.
TITLE SCHEMATIC, MODEL HV-1544			SCALE
PART NO. 1-3000V, 20MA			SCALE
DRAWN R.A.S.	CHECKED S.C.	APPROVED	
DATE 6/27/63	DATE 8/8/63	DATE 8/16/63	

**Power Designers inc.**  
NEW YORK

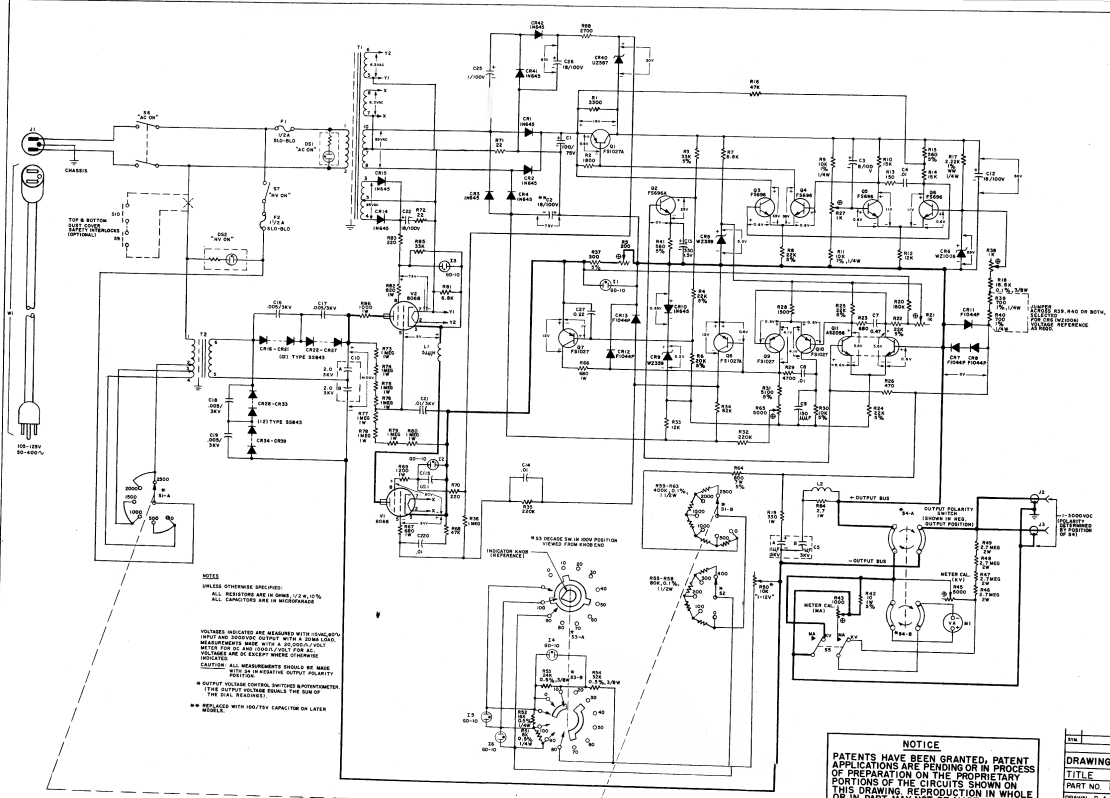

NOTES  
 UNLESS OTHERWISE SPECIFIED:  
 ALL RESISTORS ARE IN OHMS UNLESS OTHERWISE SPECIFIED.  
 VOLTAGES INDICATED ARE MEASURED WITH INSTRUMENTS  
 HAVING AN IMPEDANCE OF AT LEAST 10,000 OHMS PER  
 VOLT. MEASUREMENTS MADE WITH A 50,000 OHMS PER  
 VOLT INSTRUMENT ARE DEVELOPED FOR ALL  
 INDICATED. ALL MEASUREMENTS SHOULD BE MADE  
 ACROSS THE OUTPUT POLARITY.  
 \* OUTPUT VOLTAGE CONTROL ADJUSTERS SHOWN WITH  
 THE OUTPUT VOLTAGE EQUAL TO THE RATED  
 VALUE OF THE OUTPUT.  
 \*\* RELAYER WITH 100-75V CAPACITY ON LATER  
 MODEL.

NOTICE  
 PATENTS HAVE BEEN GRANTED. PATENT  
 APPLICATIONS ARE PENDING OR IN PROCESS  
 OF PREPARATION ON THE PROPRIETARY  
 PORTIONS OF THE CIRCUITS SHOWN ON  
 THIS DRAWING. REPRODUCTION IN WHOLE  
 OR IN PART MAY NOT BE MADE WITHOUT  
 PERMISSION.

REV.	DESCRIPTION	DATE
1	REVISED	

DRAWING NO. PS-1544-18  
 TITLE SCHEMATIC, MODEL HV-1544  
 PART NO. 1-3000V, 20MA SCALE  
 DRAWN R.A.S. CHECKED S.C.  
 DATE 5/27/53 DATE REVISED DATE 7/1/53

**Power Designers Inc.**  
 NEW YORK

FACE

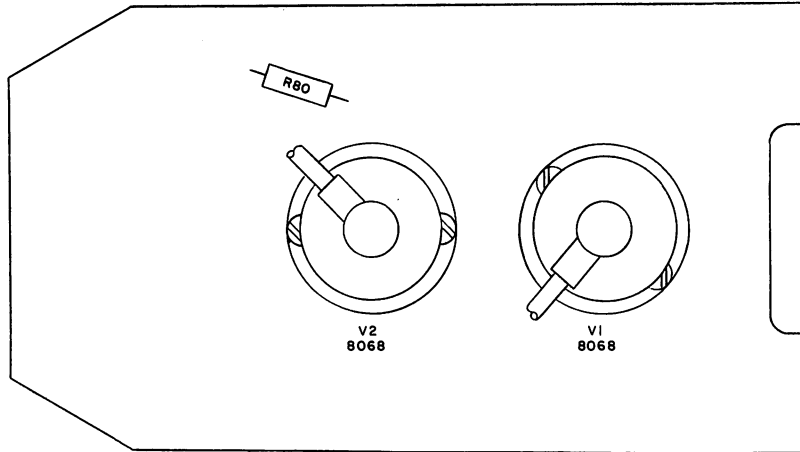

REAR

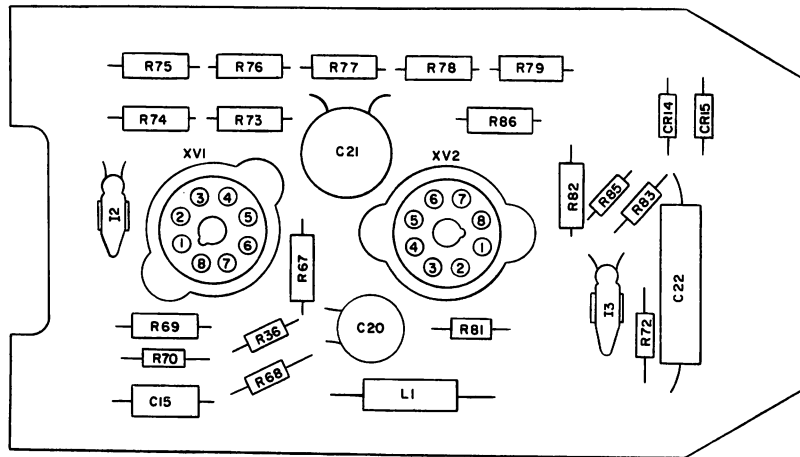

PS-1544-8  
TUBE MOUNTING BOARD ASSY

FACE

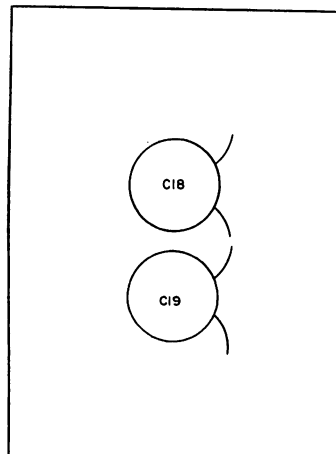

REAR

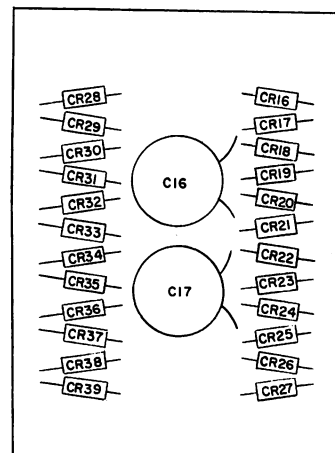

PS-1544-4  
DIODE BOARD ASSY

FACE

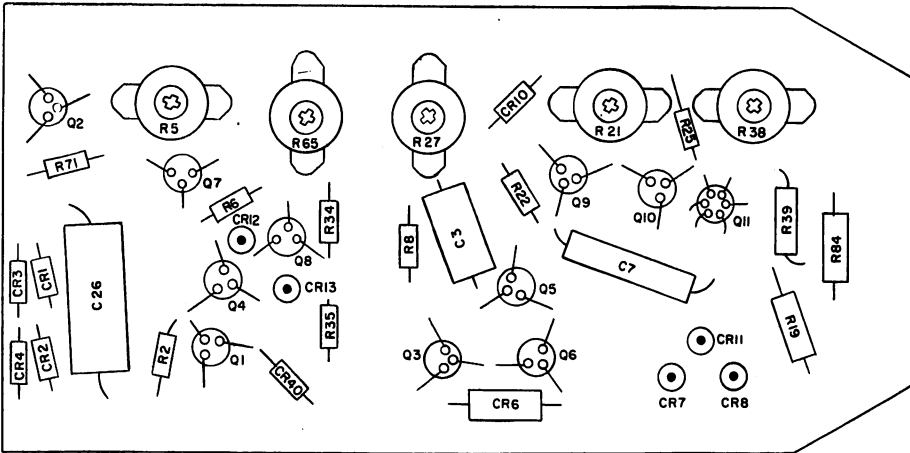

REAR

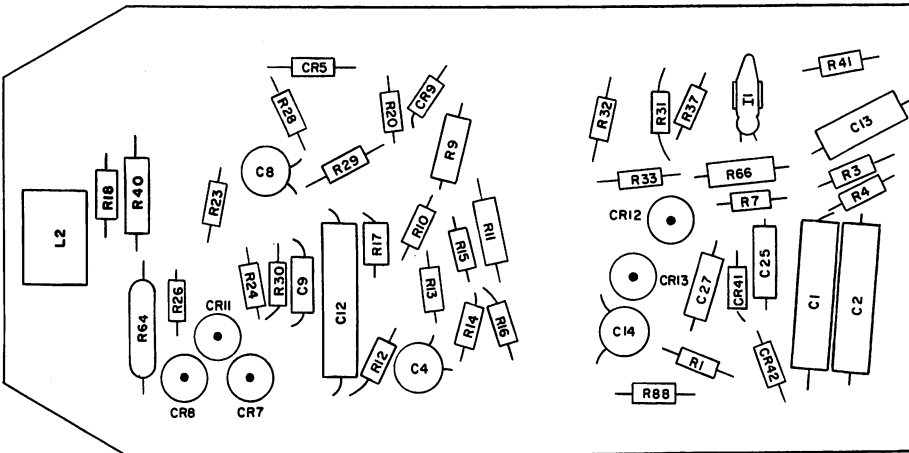

PS-1544-6  
AMPLIFIER BOARD ASSY

FACE

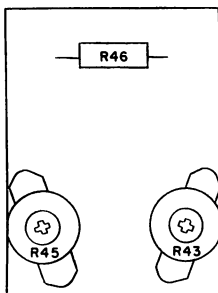

REAR

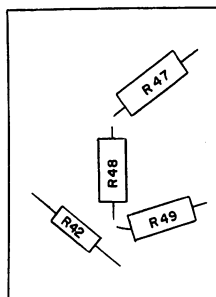

PS-1544-10  
METER BOARD ASSY

SYM.	DESCRIPTION	APPR.	DATE
REVISIONS			
DRAWING NO. PS-1544-31			REV.
TITLE TERMINAL BOARDS, LOCATION OF COMPONENTS, MODEL HV-1544			
DRAWN S.J.M.	CHECKED /j/	APPROVED /j/	
DATE 11-7-63	DATE 1/20/64	DATE 1/20/64	
 NEW YORK			

OCTOBER 1963

ELECTRICAL PARTS LIST, MODEL HV-1544

- NOTES: 1. ITEMS WHICH BEAR NO FACTORY PART NUMBER ARE STANDARD COMPONENTS AVAILABLE FROM YOUR REGULAR ELECTRONIC PARTS DISTRIBUTOR.
2. REPLACEMENT TRANSISTORS SHOULD BE OBTAINED FROM POWER DESIGNS INC. COMMERCIALY EQUIVALENT TRANSISTORS HAVE WIDE PARAMETER TOLERANCES WHICH MAY RENDER THEM UNSUITABLE FOR USE IN D-C AMPLIFIER CIRCUITRY. REPLACEMENT OF TRANSISTORS WITH COMMERCIAL EQUIVALENTS MAY RESULT IN DEGRADATION OF PERFORMANCE.
3. ALL ELECTROLYTIC CAPACITORS ARE HIGH PURITY FOIL "COMPUTER QUALITY" TYPES WITH A LIFE EXPECTANCY IN EXCESS OF 10 YEARS.

<u>CIRCUIT DESIGNATION</u>	<u>DESCRIPTION</u>	<u>FACTORY PART NO.</u>
C1	CAPACITOR, 100 MFD, 75VDC, ELECTROLYTIC	CE-79-.75
*C2, C12, C22, C26	CAPACITOR, 18MFD, 100VDC, ELECTROLYTIC	CE-48-1
C3	CAPACITOR, 8MFD, 100VDC, ELECTROLYTIC	CE-42-1
C4, C8, C14, C20	CAPACITOR, 0.01MFD, 1 KV, CERAMIC, DISC	CC-13-10
C5A	CAPACITOR, DUAL, 1MFD, 3KV, MYLAR, PAPER	CO-23-30
C5B	CAPACITOR, PART OF C5A	-----
C7	CAPACITOR, 0.47MFD, 75VDC, PLASTIC FILM	CP-20-.75
C9	CAPACITOR, 150MMFD, 600 VDC, CERAMIC, TUBULAR	CC-31-6
C10A	CAPACITOR, DUAL, 2MFD, 3KV, OIL FILLED PAPER	CO-24-30
C10B	CAPACITOR, PART OF C10A	-----
C13	CAPACITOR, 330MFD, 1.5VDC, ELECTROLYTIC	CE-77-.015
C15	CAPACITOR, 0.1MFD, 200 VDC, PLASTIC FILM	CP-17-2
C16 THRU C19	CAPACITOR, .005MFD, 3KV, CERAMIC, DISC	CC-29-30
C21	CAPACITOR, 0.01 MFD, 3K CERAMIC, DISC	CC-28-30
C25	CAPACITOR, 1MFD, 100VDC, ELECTROLYTIC	CE-59-1
C27	CAPACITOR, 0.22MFD, 50VDC, PLASTIC FILM	CP-21-.5
CR1 THRU CR4		
CR10, CR14, CR15		
CR41, CR42	DIODE, SILICON, RECTIFIER	1N645
CR5, CR9	DIODE, SILICON, ZENER	WZ359
CR6	DIODE, SILICON, ZENER, VOLTAGE REFERENCE	WZ1006
CR7, CR8, CR11,		
CR12, CR13	DIODE, SILICON	F1044P
CR16 THRU CR39	DIODE, SILICON, RECTIFIER	SS843
CR40	DIODE, SILICON, ZENER	UZ587
DS1, DS2	PILOT LAMP ASSEMBLY, NEON	PLA-3
F1	FUSE, 1/2 AMP, TYPE MDL, "SLO-BLO"	-----
F2	FUSE, 1 1/2 AMPS, TYPE MDX, "SLO-BLO"	-----
I1, I2, I3,		
I4, I5, I6	LAMP, NEON	GD-10
L1	CHOKE, 5 MICRO HENRIES	
L2	CHOKE, OHMITE TYPE Z50	PS-1544-25

ELECTRICAL PARTS LIST, MODEL HV-1544 (CONTINUED)

<u>CIRCUIT DESIGNATION</u>	<u>DESCRIPTION</u>	<u>FACTORY PART NO.</u>
M1	METER, VOLT-AMMETER, DUAL SCALE 0-3KV/0-20 MA, 2 1/2" RECT.	MVA-102
Q1, Q8	TRANSISTOR, PNP, SILICON	FS1027A
Q2,	TRANSISTOR, NPN, SILICON	FS696A
Q3 THRU Q6	TRANSISTOR, NPN, SILICON	FS696
Q7, Q9, Q10	TRANSISTOR, PNP, SILICON	FS1027
Q11	TRANSISTOR, DUAL, NPN, SILICON PLANAR	AS2056
R1	RESISTOR, 3300 $\Omega$ , 1/2W, $\pm 10\%$ , COMPOSITION	-----
R2	RESISTOR, 1800 $\Omega$ , 1/2W, $\pm 10\%$ , COMPOSITION	-----
R3	RESISTOR, 33K $\Omega$ , 1/2W, $\pm 5\%$ , COMPOSITION	-----
R4, R8, R22, R24, R25	RESISTOR, 22 K $\Omega$ , 1/2W, $\pm 5\%$ , COMPOSITION	-----
R5	RESISTOR, ADJUSTABLE TRIMMER, 200 $\Omega$ , 1 1/4W, $\pm 10\%$ , WIREWOUND	RWT-201-C4
R6	RESISTOR, 20K $\Omega$ , 1/2W, $\pm 5\%$ , COMPOSITION	-----
R7, R81	RESISTOR, 6.8K $\Omega$ , 1/2W, $\pm 10\%$ , COMPOSITION	-----
R9, R11	RESISTOR, 10K $\Omega$ , 1/4W, $\pm 1\%$ , PRECISION	RD-103-1Q
R10, R14	RESISTOR, 15K $\Omega$ , 1/2W, $\pm 10\%$ , COMPOSITION	-----
R12, R33	RESISTOR, 12K $\Omega$ , 1/2W, $\pm 10\%$ , COMPOSITION	-----
R13	RESISTOR, 150 $\Omega$ , 1/2W, $\pm 10\%$ , COMPOSITION	-----
R15, R41	RESISTOR, 560 $\Omega$ , 1/2W, $\pm 5\%$ , COMPOSITION	-----
R16, R68	RESISTOR, 47K $\Omega$ , 1/2W, $\pm 10\%$ , COMPOSITION	-----
R17	RESISTOR, 2.22K $\Omega$ , 1/4W, $\pm 1\%$ , PRECISION	RW-2.22-1Q
R18	RESISTOR, 18.8K $\Omega$ , 3/8W, $\pm 1\%$ PRECISION	RW-18.82-1S
R19	RESISTOR, 330 $\Omega$ , 1W, $\pm 10\%$ , COMPOSITION	-----
R20	RESISTOR, 180K $\Omega$ , 1/2W, $\pm 10\%$ , COMPOSITION	-----
R21, R27, R38, R43	RESISTOR, ADJUSTABLE TRIMMER, 1K $\Omega$ , 1 1/4W, $\pm 10\%$ , WIREWOUND	RWT-102-C4
R23	RESISTOR, 680 $\Omega$ , 1/2W, $\pm 10\%$ , COMPOSITION	-----
R26	RESISTOR, 470 $\Omega$ , 1/2W, $\pm 10\%$ , COMPOSITION	-----
R28	RESISTOR, 1500 $\Omega$ , 1/2W, $\pm 10\%$ , COMPOSITION	-----
R29	RESISTOR, 4700 $\Omega$ , 1/2W, $\pm 10\%$ , COMPOSITION	-----
R30	RESISTOR, 10K $\Omega$ , 1/2W, $\pm 5\%$ , COMPOSITION	-----
R31	RESISTOR, 5100 $\Omega$ , 1/2W, $\pm 5\%$ , COMPOSITION	-----
R32, R35	RESISTOR, 220K $\Omega$ , 1/2W, $\pm 10\%$ , COMPOSITION	-----
R34	RESISTOR, 82K $\Omega$ , 1/2W, $\pm 10\%$ , COMPOSITION	-----
R36	RESISTOR, 82K $\Omega$ , 1/2W, $\pm 10\%$ , COMPOSITION	-----
R37	RESISTOR, 300 $\Omega$ , 1/2W, $\pm 5\%$ , COMPOSITION	-----
R39, R40	RESISTOR, 700 $\Omega$ , 1/4W, $\pm 1\%$ PRECISION	RD-701-1Q
R42	RESISTOR, 10 $\Omega$ , 1W, $\pm 5\%$ , COMPOSITION	-----
R45, R65	RESISTOR, ADJUSTABLE TRIMMER, 5K $\Omega$ , 1 1/4W, $\pm 10\%$ , WIREWOUND	RWT-502-C4
R46 THRU R49	RESISTOR, 2.7 MEG. $\Omega$ , 2W, $\pm 10\%$ , COMPOSITION	-----
R50	RESISTOR, VARIABLE, (1-12 VOLTS ADJUST) 10K $\Omega$ , 4W, $\pm 10\%$ , WIREWOUND	RWV103M4-2.12

ELECTRICAL PARTS LIST, MODEL HV-1544 (CONTINUED)

<u>CIRCUIT DESIGNATION</u>	<u>DESCRIPTION</u>	<u>FACTORY PART NO.</u>
R51	RESISTOR, 8K $\Omega$ , 1/4W, $\pm 5\%$ , PRECISION	RW-802-6Q
R52	RESISTOR, 16K $\Omega$ , 1/4W, $\pm 5\%$ , PRECISION	RW-163-6Q
R53	RESISTOR, 24K $\Omega$ , 3/8W, $\pm 5\%$ , PRECISION	RW-243-6S
R54	RESISTOR, 32K $\Omega$ , 3/8W, $\pm 5\%$ , PRECISION	RW-323-6S
R55 THRU R58	RESISTOR, 80K $\Omega$ , 1 1/2W, $\pm 1\%$ , PRECISION	RW-803-8T
R59 THRU R63	RESISTOR, 400K $\Omega$ , 1 1/2W, $\pm 1\%$ , PRECISION	RW-404-8T
R64	RESISTOR, 800 $\Omega$ , 7W, $\pm 5\%$ , WIREWOUND	RW-801-3RA
R66, R67	RESISTOR, 680 $\Omega$ , 1W, $\pm 10\%$ , COMPOSITION	-----
R69	RESISTOR, 1200 $\Omega$ , 1W, $\pm 10\%$ , COMPOSITION	-----
R70, R83	RESISTOR, 220 $\Omega$ , 1/2W, $\pm 10\%$ , COMPOSITION	-----
R71, R72	RESISTOR, 22 $\Omega$ , 1/2W, $\pm 10\%$ , COMPOSITION	-----
R73 THRU R80	RESISTOR, 1 MEG. $\Omega$ , 1W, $\pm 10\%$ , COMPOSITION	-----
R82	RESISTOR, 820 $\Omega$ , 1W, $\pm 10\%$ , COMPOSITION	-----
R84	RESISTOR, 2.7 $\Omega$ , 1W, $\pm 10\%$ , COMPOSITION	-----
R85	RESISTOR, 33K $\Omega$ , 1/2W, $\pm 10\%$ , COMPOSITION	-----
R86	RESISTOR, 1K $\Omega$ , 1W, $\pm 10\%$ , COMPOSITION	-----
R88	RESISTOR, 2700 $\Omega$ , 1/2W, $\pm 10\%$ , COMPOSITION	-----
S1	SWITCH, ROTARY, (0-2500V)	PS-1544-22
S2	SWITCH, ROTARY, (0-400V)	PS-1565-26
S3	SWITCH, ROTARY, (0-100V)	PS-1565-28
S4	SWITCH, ROTARY, (POLARITY REVERSAL)	PS-1565-30
S5	SWITCH, TOGGLE, DPDT, MOMENTARY SPRING RETURN	ST-17
S6	SWITCH, TOGGLE, DPST, 15A, 125 VAC	ST-3
S7	SWITCH, TOGGLE, SPST, 15A, 125 VAC	ST-5
T1	TRANSFORMER, POWER	659
T2	TRANSFORMER, PLATE	655
V1, V2	TUBE, 8068	-----
J1	CONNECTOR, RECEPTACLE, AMPHENOL #160-5	-----
J2, J3	CONNECTOR, HV CO AXIAL RECEPTACLE, TYPE 70-03	5134
P2	CONNECTOR, HV CO AXIAL PLUG, TYPE 59-03 (RG-59/U)	5135
W1	LINE CORD	B63052



POWER DESIGNS INC.

"CONTROLLED PARAMETER"

SEMI-CONDUCTOR CODE

EXAMPLE:

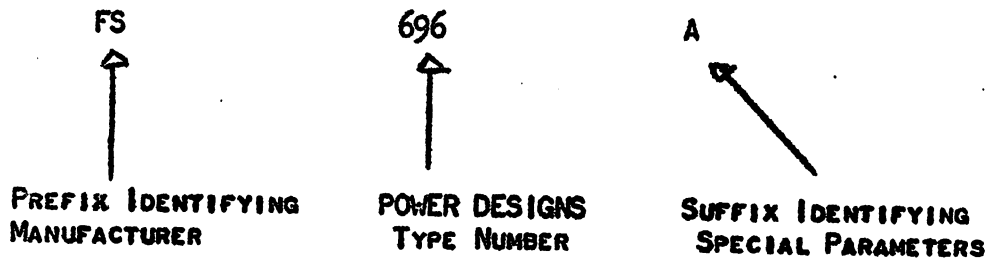

REPLACEMENT SEMICONDUCTORS WITH THE SAME POWER DESIGNS  
TYPE NUMBER AND SUFFIX, ARE DIRECTLY INTERCHANGEABLE.

## **WARRANTY**

POWER DESIGNS INC., warrants to the original purchaser, each instrument sold by us, or our authorized agents, and all the parts thereof, to be free from defects in material or workmanship under normal use and service within the specified ratings and operating conditions.

Its obligation under this warranty is hereby limited to the repair or replacement of any instrument, or part thereof, which is returned to us within one year after delivery, and which shall prove, after our examination, to be thus defective.

This warranty does not include the cost of transportation charges to and from the factory and/or the cost of packaging or crating of instruments for return to the factory, unless such instrument is returned within thirty (30) days from the date of original shipment as shown on the packing list or shipping documents, and prior written authorization for such costs is obtained from the factory.

The repair or replacement of an instrument, or any part thereof, does not void or extend the original warranty.

POWER DESIGNS INC., reserves the right to discontinue any instrument without notice, or to make modifications in design at any time, without incurring any obligation to make these modifications in instruments previously sold.

**POWER DESIGNS INC.**

Westbury, L. I., New York

**POWER DESIGNS PACIFIC, INC.**

Palo Alto, California

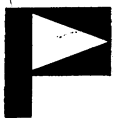

19 November 1965

Federal Electric Corporation  
2128 Stanford, S. E.  
Albuquerque, New Mexico

Reference: Purchase Order received via Telegram

Gentlemen:

In response to your telegraphic order of today for one each Manual for Power Designs Model 1544 power supply we are enclosing the manual herewith.

There will be no charge for this manual.

If you desire any further information about Power Designs Pacific, Inc., and our products, our representatives in your area are Wright Engineering, 15 North 40th Place, Phoenix. Either they or the undersigned will be most happy to assist you.

Sincerely yours

POWER DESIGNS PACIFIC, INC.

Dr. David H. Simmons  
President

DHS:rd  
Via Air Mail

cc: Wright Engineering