

Service Manual



Power Supply NGMO1 and Power Supply NGMO2

192.1500.21 and 192.1500.24



Service Manual

Power Supply NGMO1 and

Power Supply NGMO2

Edition: May 2014

Version: 3.00

All rights reserved, including translation into foreign languages. No part of this manual may be reproduced or reworked using electronic systems, duplicated or distributed in any form (photocopying, microfilm or any other process), not even for instructional purposes, without written permission from **ROHDE & SCHWARZ** GmbH & Co. KG.

© Disclosure or reproduction of this documentation, utilization and communication of its contents is not permitted, without express approval. Infringements will lead to claims for compensation. All rights reserved in the event of patents being granted or registration of a protected design.

© 2013 Rohde & Schwarz GmbH & Co. KG

Muehldorfstr. 15, 81671 Munich, Germany

Phone: +49 89 41 29 - 0

Fax: +49 89 41 29 12 164

E-Mail: info@rohde-schwarz.com









Internet: <http://www.rohde-schwarz.com>

Safety Instructions

This unit has been designed and tested in accordance with the EC Certificate of Conformity and has left the manufacturer's plant in a condition fully complying with safety standards.

To maintain this condition and to ensure safe operation, the user must observe all instructions and warnings given in this operating manual.

Safety-related symbols used on equipment and documentation from R&S:

							
Observe operating instructions	Weight indication for units >18 kg	PE terminal	Ground terminal	Danger! Shock hazard	Warning! Hot surfaces	Ground	Attention! Electrostatic sensitive devices require special care

- The unit may be used only in the operating conditions and positions specified by the manufacturer. Unless otherwise agreed, the following applies to R&S products:

IP degree of protection 2X, Pollution severity 2, overvoltage category 2, altitude max. 2000 m.

The unit may be operated only from AC supply mains fused with max. 16 A.
- For measurements in circuits with voltages $V_{rms} > 30$ V, suitable measures should be taken to avoid any hazards.

(e.g. use of appropriate measuring equipment, fusing, current limiting, electrical separation, insulation).
- If the unit is to be permanently wired, the PE terminal of the unit must first be connected to the PE conductor on site before any other connections are made. Installation and wiring of the unit should only be performed by qualified technical personnel.
- For permanently installed units without built-in fuses, circuit breakers or similar protective devices, the supply circuit must be fused such as to provide suitable protection for the users and equipment.
- Prior to switching on the unit, it must be ensured that the nominal voltage set on the unit matches the nominal voltage of the AC supply network.
- If a different voltage is to be set, the power fuse of the unit may have to be changed accordingly.
- Units of protection class I with disconnectible AC supply cable and appliance connector may be operated only from a power socket with grounding contact and with the PE conductor connected.
- It is not permissible to interrupt the PE conductor intentionally, neither in the incoming cable nor on the unit itself, as this may cause the unit to become electrically hazardous.

Any extension lines or multiple socket outlets used must be checked for compliance with relevant safety standards at regular intervals.
- If the unit has no power switch for disconnection from the AC supply, the plug of the connecting cable is regarded as the disconnecting device. In such cases it must be ensured that the power plug is easily reachable and accessible at all times (length of connecting cable approx. 2 m). Functional or electronic switches are not suitable for providing disconnection from the AC supply.

If units without power switches are integrated in racks or systems, a disconnecting device must be provided at system level.

continued overleaf

Safety Instructions

9. Applicable local or national safety regulations and rules for the prevention of accidents must be observed in all work performed.

Prior to performing any work on the unit or opening the unit, the latter must be disconnected from the supply network.

Any adjustments, replacements of parts, maintenance or repair may be carried out only by authorized R&S technical personnel.

Only original parts may be used for replacing parts relevant to safety (e.g. power switches, power transformers, fuses). A safety test must be performed after each replacement of parts relevant to safety.

(visual inspection, PE conductor test, insulation-resistance, leakage-current measurement, function test).

10. Ensure that the connections with information technology equipment comply with IEC950 / EN60950.
11. Lithium batteries must not be exposed to high temperatures or fire.
- Keep batteries away from children.
- If the battery is replaced improperly, there is danger of explosion. Only replace the battery by R&S type (see spare part list).
- Lithium batteries are suitable for environmentally friendly disposal or specialized recycling. Dispose of them in appropriate containers only.
- Do not short-circuit the battery.

12. Equipment returned or sent in for repair must be packed in the original packing or in packing with electrostatic and mechanical protection.
13. Electrostatics via the connectors may damage the equipment. For the safe handling and operation of the equipment, appropriate measures against electrostatics should be implemented.
14. The outside of the instrument is suitably cleaned using a soft, lint-free dust cloth. Never use solvents such as thinners, acetone or similar, as they may damage the front panel labelling or plastic parts.
15. Any additional safety instructions given in this manual are also to be observed.



Contents

1	User Information	1-1
1.1	NGMO-Versions	1-1
1.1.1	NGMO1	1-1
1.1.2	NGMO2	1-1
1.2	Purpose of the Handbook	1-1
1.3	Important User Notes	1-2
1.4	Explanation of Symbols	1-3
2	Customer Service	2-1
2.1	Service Addresses	2-1
2.1.1	Technical Support	2-1
2.1.2	Ordering Spare Parts and Test Equipment	2-1
3	Safety	3-1
3.1	General	3-1
3.2	Safety Instructions	3-1
4	Unit Description	4-1
4.1	Introduction	4-1
4.2	Function Description	4-2
4.2.1	Prozessor Board	4-2
4.2.2	Keyboard / Display	4-3
4.2.3	Analog Boards, CHN "A" and "B"	4-3
5	Operation	5-1
6	Maintenance	6-1
6.1	General	6-1
6.2	Maintenance Intervals	6-1
6.3	Calibration Intervals	6-1
6.4	Cleaning	6-2
7	Calibration	7-1
7.1	Calibration Equipment	7-1
7.1.1	Calibration Adapter	7-1
7.2	Calibration Set-up	7-2



7.3	Calibration Procedure	7-3
7.4	The Calibration Entry ID got lost	7-10
8	Repair	8-1
8.1	Function Tests by using the Service Functions	8-1
8.1.1	Selecting the Interfaces to be used	8-2
8.1.2	Setting the Electronic Serial Number	8-3
8.1.3	Setting the NGMO Device Name (from firmware version 1.10)	8-4
8.1.4	Communication Test with Analog Boards	8-5
8.1.4.1	Commands for channel: A	8-5
8.1.4.2	Commands for channel: B	8-5
8.1.5	Display Blank Test	8-6
8.1.6	Display Unblank Test	8-7
8.1.7	Keyboard and Knob Test	8-8
8.1.8	Control I/O Test	8-10
8.1.9	INHIBIT ON	8-12
8.1.10	Switching off Test Functions	8-14
8.2	Error Messages in the Display	8-15
8.3	Checking the Output Voltages	8-16
8.3.1	Processor Board	8-16
8.3.2	Analog Boards	8-17
8.4	General Troubleshooting	8-18
9	Removal and Installation of Assemblies	9-1
9.1	Removal of Assemblies	9-2
9.1.1	Removing the Housing	9-2
9.1.2	Removing of the Analog Board Y101, Y102	9-3
9.1.2.1	Analog board Y101 (Channel A)	9-3
9.1.2.2	Analog board Y102 (Channel B)	9-3
9.1.3	Removing of Keyboard Y202	9-4
9.1.4	Removing of Processor Board Y301	9-5
9.1.5	Removing of Fans A, B	9-6
9.2	Installation of Assemblies	9-7
9.2.1	Installation of the Analog Boards Y101, Y102	9-7
9.2.1.1	Analog board Y101 (Channel A)	9-7
9.2.1.2	Analog board Y102 (Channel B)	9-7
9.2.2	Installation of the Keyboard Y202	9-7
9.2.3	Installation of Processor Board Y301	9-8
9.2.4	Installation of Fans A, B	9-8
9.2.5	Assembling the Unit	9-8
10	Interfaces	10-1



10.1	OUTPUT A / OUTPUT B (Channel A/Channel B)	10-2
10.2	CONTROL I/O (Relay Connector, SUB 15, Male)	10-3
11	Bill of Materials	11-1
12	Software Update	12-1
12.1	Components List	12-1
12.2	Running the Update	12-1



Figures

Fig. 4-1 Power Supply NGMO2 , Overall view	4-1
Fig. 4-2 Power Supply NGMO, Function block diagram	4-5
Fig. 5-1 Power Supply NGMO2 , Operation elements	5-1
Fig. 5-2 Power Supply NGMO2 , Connections on rear side of unit	5-4
Fig. 7-1 Calibration adapter	7-1
Fig. 7-2 Power Supply NGMO, Calibration set-up	7-2
Fig. 8-1 Test set-up for Control I/O test	8-10
Fig. 8-1 Test set-up for INHIBIT ON test	8-12
Fig. 8-3 NGMO Output plug (2 pcs.)	8-12
Fig. 10-1 Power Supply NGMO2, non-standardized interfaces	10-1

1 User Information

1.1 NGMO-Versions

**NOTE:**

The Power Supply is available in different versions.

This Service Manual contains descriptions for all versions. In chapters with differences in the description of the individual Power Supplies, such differences will be specially emphasized.

The designation NGMO is used wherever the description applies for all versions.

1.1.1 NGMO1

The Power Supply NGMO1 consists of the following assemblies:

- Keyboard with LC Display
- Processor board
- Analog board for Channel A
- Power supply unit

1.1.2 NGMO2

The NGMO2 is equipped with two analog boards and therefore delivers two separate voltage sources and signal channels. Apart from that the Power Supplies are absolutely identical.

1.2 Purpose of the Handbook

The Service Handbook provides the information necessary for

- Fault finding and
- Fault rectification

on the Power Supply NGMO.

The Service Manual must be read carefully by the operator / service engineer tasked with working on the Power Supply prior to performing service tasks.



Apart from the Service Manual, the Operating Manual, the health and safety regulations applicable in the place where the unit is used, as well as the applicable technical standards and regulations on safety and correct working are to be observed.

The operating organisation is to extend the service instructions, as necessary, with information on national health and safety regulations, and environmental regulations.

1.3 Important User Notes

NOTE:



Only personnel authorized by ROHDE & SCHWARZ may open the Power Supply NGMO.

If the safety regulations for the Power Supply NGMO are disregarded, ROHDE & SCHWARZ GmbH & Co KG will not assume liability for any resulting damage and all warranties will become null and void.

When working with the Service Manual, the information contained in the Operating Manual “Power Supply NGMO” must also be observed.

1.4 Explanation of Symbols

The Power Supply NGMO was produced according to the generally accepted regulations governing the technology and current status of science and technology.

However, it is impossible to design hazard-free electrical equipment.

In order to guarantee a sufficient level of safety for personnel working with the Power Supply NGMO, safety regulations must be observed.

Certain sections of the text are highlighted as follows:



Danger!

Failure to follow instructions can result in personal injury!



ELECTROCUTION HAZARDS!

Observe the relevant safety regulations when operating electrical devices.



WARNING!

Failure to follow the instructions could damage the Power Supply NGMO.



ATTENTION!

Failure to follow the instructions may cause spurious results.



NOTE:

Emphasizes significant details, the observance of which is of particular importance and which facilitate operation.





2 Customer Service

The addresses of the Rohde & Schwarz Head Offices, Branch Offices and Service Stations are listed on the internet pages:

<http://www.rohde-schwarz.com>

2.1 Service Addresses

2.1.1 Technical Support

If you have any technical queries concerning this Rohde & Schwarz equipment, please call us, we will be glad to help.

Our team will discuss your queries and look for solutions to your problems.

**ROHDE & SCHWARZ**

Customer Support Center

Phone: +49 89 4129 12345

E-mail: customersupport@rohde-schwarz.com

2.1.2 Ordering Spare Parts and Test Equipment

The spare parts and test equipments required for the Power Supply NGMO can be ordered from the following address:

**ROHDE & SCHWARZ**

Customer Support Center

Phone: +49 89 4129 12345

E-mail: customersupport@rohde-schwarz.com



3 Safety

3.1 General

During service work on the Power Supply NGMO, the safety regulations applicable in the country of use must be observed.

NOTE



Only personnel authorized by ROHDE & SCHWARZ may open the Power Supply NGMO.

If the safety regulations for the Power Supply NGMO are disregarded, ROHDE & SCHWARZ GmbH & Co KG will not assume liability for any resulting damage and all warranties will become null and void.

3.2 Safety Instructions



ELECTROCUTION HAZARDS!

Observe the relevant safety regulations when operating electrical devices.

Prior to working on the Power Supply NGMO, it is to be isolated from the mains power supply.



WARNING!

Failure to follow the instructions could damage the Power Supply NGMO.

Do not bridge defective fuses. Defective fuses must strictly be replaced with fuses of the same rating.

The electrical connections on the Power Supply NGMO are to be checked at regular intervals. Defects, such as loose connections, or chaffed cables must be rectified immediately.



4 Unit Description



Fig. 4-1 Power Supply **NGMO2**, Overall view

4.1 Introduction

The Power Supply NGMO is accommodated in a 1/2-19", 2 HU (high units) enclosure.

The NGMO is more, than just a power supply for conventional test and measurement equipment, - it is an accurate, multipurpose electronic device with two separate supply and measurement channels (NGMO2 only, NGMO1 only Channel A) which can be used as the following:

- high speed voltage source,
- programmable DC load,
- precise digital multimeter,
- sampling oscilloscope,

This unit fulfils all requirements of latest electronic battery-powered communication products.

The high speed and the high reliability are features which are very important in a production environment.

The NGMO is an ideal device for testing complex high-tech products such as mobile phones. With the NGMO, it is possible to create reproducible and realistic powering conditions.

4.2 Function Description

The schedule at the service design concept is to replace the following modules when a fault occurs.

- Processor board
- Keyboard / Display
- Analog board "A" (NGMO1)
- Analog boards "A" and "B" (NGMO2)

4.2.1 Prozessor Board

Apart from the control processor, its periphery and all data interfaces the processor board also contains the rectification and filtering for the electric power supply of the overall unit.

For this purpose the unit is equipped with two separate power supplies with a transformer each. The mains supply voltage is channel separated and fed to the transformers via two fusible cut-outs on the processor board. Separate fuses for 115VAC and 230 VAC are present.

The secondary voltages supplied by the transformers are rectified and filtered on the processor board. Each of the two power supplies delivers three non-stabilized direct voltages (approx. 8 VAC, 16 VAC, 21 VAC) via the lateral connectors to the analog boards. A separate winding of one of the two transformers generates the processor supply voltage (+5 VDC) and stabilizes it on the board. On the processor board all direct voltages are indicated by LEDs.

The alternating voltages arriving from the transformers are protected by SMD-fuses directly after the connectors.

The processor establishes the data exchange between the remote control interfaces (RS232 and IEEE) and the signal processors on both analog boards, interprets and saves measuring data as well as control commands from the interfaces and from the keyboard. It additionally presents data and modes on the display.

The periphery of the control processor consists of a main memory, an EEPROM for storage of calibration data and adjustments as well as a Flash-ROM to store the Firmware.

A serial interface RS232 and an IEEE-488-2 connection accommodate remote control. Apart from that the unit contains a Control Interface with control lines and relay drivers.

4.2.2 Keyboard / Display

The NGMO control unit consists of the keyboard with rotary transducer and the detached LC display.

The display is connected to the keyboard via a cable for data and power supply and another two-pole cable for the LED background illumination. From the keyboard a common ribbon cable runs to the processor board. The control processor on the processor board reads out keys and rotary transducer and presents the up-to-date data on the display.

4.2.3 Analog Boards, CHN "A" and "B"

The two analog boards Channel A and B (NGMO2 only) are electrically of identical design and offer the following functions beside the typical functions of a mains supply unit.

- Adjustable output impedance
- fast Push-Pull output stage with reversible bandwidth
- electronic load (current sink)
- high measuring and adjustment accuracy
- quick sampling of output currents and of DVM-voltage with a sampling frequency of up to 100kHz (transient measurement)
- Data storage with 5000 storage locations
- Analysis of recorded current and voltage characteristics

In addition the following safety functions:

- Detection of open sensing lines
- Overvoltage protection (cutoff in case of too high output voltage, limit adjustable)
- Overcurrent protection (cutoff or limitation to the set current value)

Communication between processor board and one or both analog boards takes place via a serial interface, which is galvanically separated by an optical isolator. The analog boards are equipped with a signal



processor (DSP) each, which takes over the control of the board and the real-time evaluation of the measuring values.

All measurements are accomplished via a fast 16Bit-A/D-converter with a series-connected multiplexer, various D/A-converters are used to adjust the output variables.

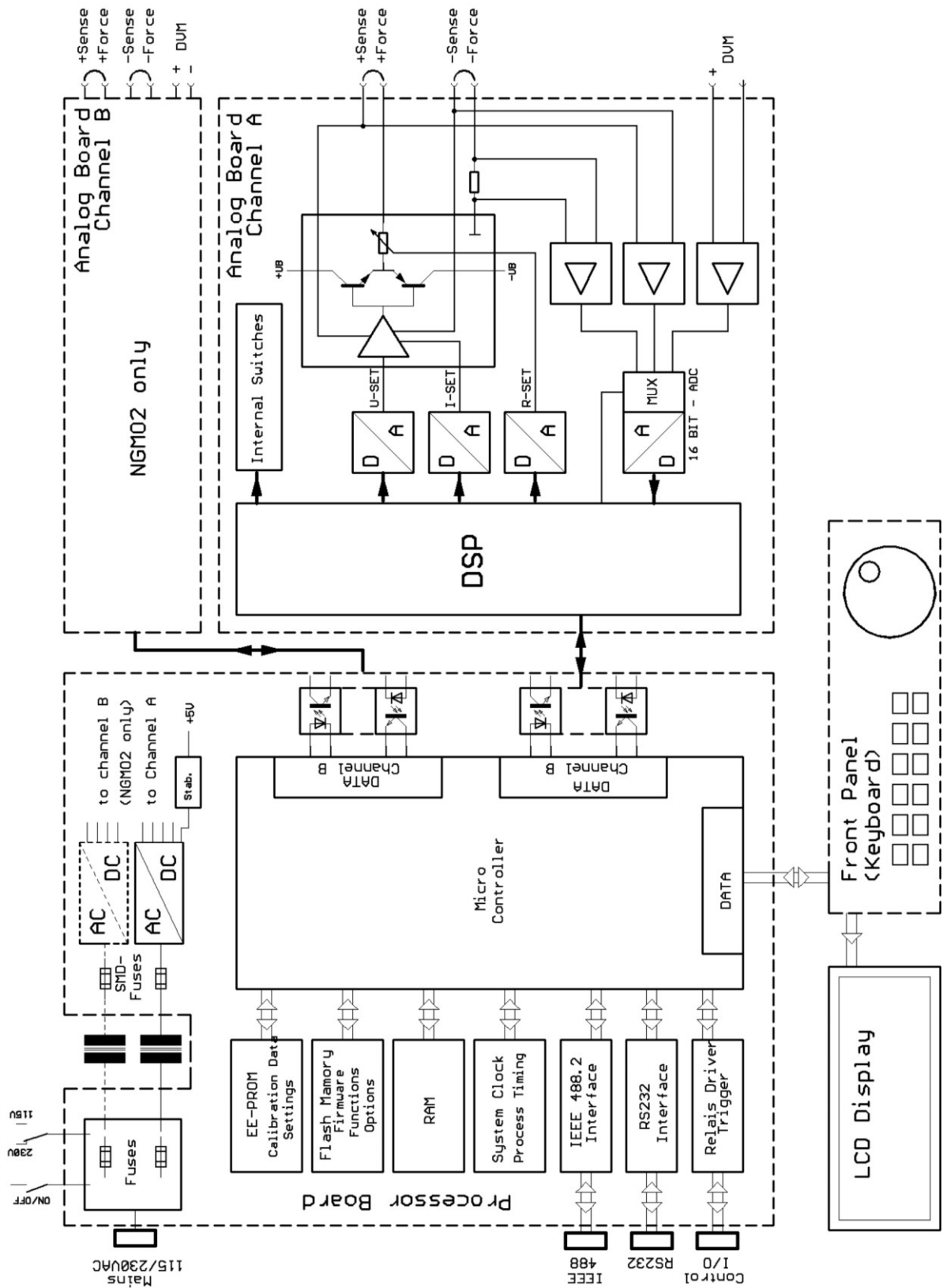


Fig. 4-2 Power Supply NGMO, Function block diagram



5 Operation

5.1 Operation Elements

Fig. 5-1 shows the Operation Elements for the Power Supply **NGMO2**.



NOTE:





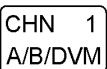
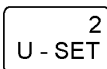
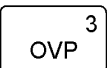


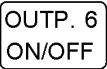
Operation elements and Start Up functions of the Power Supply **NGMO1** are identical with the **NGMO2**.
 Operation elements for channel B must in this case be ignored.
 Readings in the LC Display correspond with the respective Power Supply.


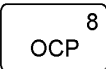
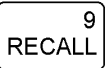

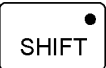



Fig. 5-1 Power Supply **NGMO2**, Operation elements

Function element	Type	Function
POWER 	pushbutton	POWER This is the mains switch to turn the NGMO on and off.
VARIATION 	rotary knob	VARIATION This knob has various functions: <ul style="list-style-type: none"> to increase or decrease numerical values in a menu function, to select options within the menu.



Function element	Type	Function
 	keys	<p>ARROW KEYS (left and right)</p> <ul style="list-style-type: none"> • When no other function is selected, the LCD contrast can be adjusted with the arrow keys. • The arrow key moves the cursor to the numerical input you want to make, • or to vary a setting within the menu. • The arrow keys can also be used to abort the recall or the save function.
	key	<p>1; CHANNEL A; CHANNEL B; 1; Digital Voltmeter A; Digital Voltmeter B</p> <p>By pressing this key, channel A or channel B and the associated DVM can be selected. The selected DVM shows an applied external voltage.</p>
	key	<p>2; Voltage setting</p> <p>Press U-SET to set the output voltage you have selected.</p> <p>The value you want and, if necessary, modified by pressing the SHIFT key or by turning the variation knob.</p>
	key	<p>3; Overvoltage protection</p> <p>By pressing the OVP key you can set the max. +force output voltage with respect to the internal ground. If the voltage peaks exceed the set value, the NGMO switches off automatically to protect the unit under test.</p>
	key	<p>4; SAVE</p> <p>With the SAVE key all settings can be stored in one of the memory locations 1 to 9, except the recall settings, IEEE address, serial interface data, calibration data, which are stored in memory location 0.</p>
	key	<p>5; MENU</p> <p>Pressing the MENU key, allows you to select any of the 36 NGMO available optional functions with the variation knob.</p> <p>A menu need not necessarily have submenus.</p>
	key	<p>6; OUTPUT; ON/OFF</p> <p>The ON/OFF key is used to turn the output of the current from the selected Power Supply (A, B or both) on or off.</p>

Function element	Type	Function
	key	<p>7; Current setting</p> <p>Press I-SET to set the output current limit of the channel you have selected. The value you want can be entered and modified after you press the SHIFT key or by turning the variation knob.</p> <p>The max. settable value is 5 V at 5 A. On a higher value than 5 V the max. current output is limited to max. 2.5 A.</p>
	key	<p>8; Overcurrent protection</p> <p>Pressing this key allows you to choose between the options “current protection mode” or “current limit mode”. When the “current protection mode” has been selected, the output is switched off when the max. output current exceeds the set current limit.</p>
	key	<p>9; RECALL</p> <p>The RECALL key is used to recall all settings stored in memory locations 1 to 9.</p> <p>Memory location 0 contains the factory default settings which can not be modified.</p>
	key	<p>0; LOCAL</p> <p>With the LOCAL key the unit operation can be switched from remote control back to local control.</p>
	key	<p>SHIFT</p> <p>When the second function of the SHIFT key is selected, numerical values and a decimal point can be entered. Cancel a selected function by pressing the SHIFT key twice.</p>
	key	<p>ENTER</p> <p>Pressing the ENTER key numerical entries made using the SHIFT key or deactivates a setting function.</p>

General Note:

- All function keys in the middle of the control panel (CHN 1 A/B/DVM to 0 LOCAL and SHIFT) are assigned two functions, e.g. apart from the main setting functions, the numerals 0 to 9 and the decimal point printed on the keys can be entered to alter values when the shift key has been pressed.
- **UUT** stands for **unit under test** in the sequel.

5.2 Connections on Rear Side of Unit

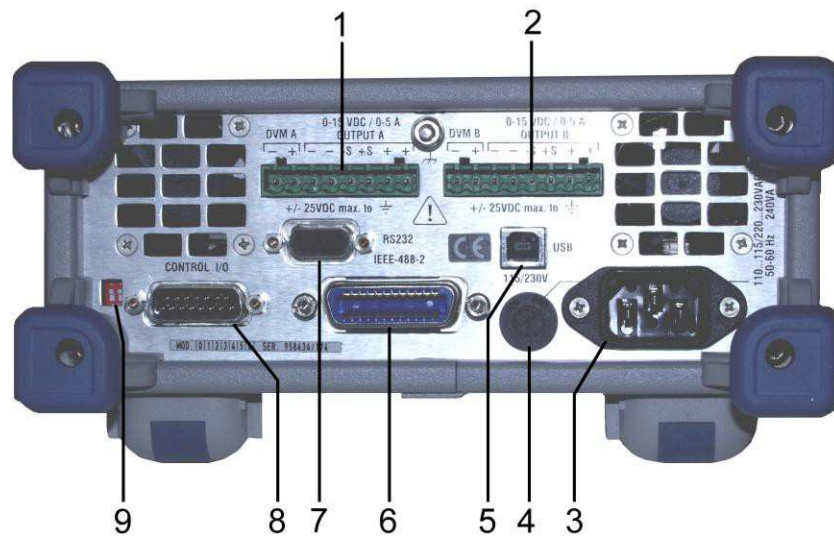


Fig. 5-2 Power Supply **NGMO2**, Connections on rear side of unit

Pos. No.	Function
1	Output Channel A / DVMA in
2	Output Channel B / DVMB in
3	Mains Connector
4	Mains Voltage Selector
5	USB Interface Connector
6	IEEE-488-2 Interface Connector
7	RS232 Interface Connector
8	Control I/O Connector
9	Switches for software update

The assignment of the non-standardized connections - Output A, Output B and Control I/O – is described in chapter 10.

5.3 Start Up

5.3.1 NGMO Line Power Connection and Power-up

The NGMO operates from a line voltage in the range 120/230 VAC at a frequency between 47 and 63 Hz.

Proceed as follows to connect the NGMO to the AC line and turn on:

1. Before plugging in the power cable, make sure that the power switch is off (the "**POWER**" switch has not been pressed and shows "OFF").
2. Check that the "**Mains Voltage Selector**" (4, Fig. 5-2) is set to the appropriate line voltage.
3. Connect the female end of the power cable to the AC receptacle on the rear panel.
4. Connect the Power Supply NGMO to the AC line.
5. Press the push button "**Power**" on the front panel.

5.3.2 Main Functions of the NGMO

When the NGMO2 is powered up, it displays the following start-up information:

Rohde & Schwarz
NGMO 2

Next screen after 4 seconds:

Ver:x.yy IEEE Adr:nn
Found: A/B Type:

Or

Ver:x.yy IEEE Adr:nn
Found: Az + Bz



Meaning:

x.yy is the version number of the currently installed firmware

x = major version number,

yy = minor version number.

nn = currently selected IEEE address for the device

Az = type of power supply board mounted at location A in the NGMO. Currently, only type 3 is available.

Bz = type of power supply board mounted at location B in the NGMO2. Currently only type 3 is available.

For further information concerning the settings on the Power Supply and the readings in the display please refer to the Operator Manual for the Power Supply NGMO1 / NGMO2.

6 Maintenance



Attention!

Work on the Power Supply NGMO must be performed in strict compliance with the ESD-regulations (electrostatic discharge).

6.1 General

In order to maintain the function and the durability of the Power Supply NGMO, care, maintenance and inspection tasks must be performed at specified intervals.

6.2 Maintenance Intervals

The following table shows the different activities concerning care, maintenance and inspection to be performed on the Power Supply NGMO at the specified intervals.

Maintenance interval	Maintenance tasks	Service point
depending on degree of soiling	<ul style="list-style-type: none"> clean 	Unit
Visual inspection before start-up	<ul style="list-style-type: none"> Check connecting cables incl. connections for damage and tight fit. 	Cables and connections
2 years	<ul style="list-style-type: none"> Check the function of the fan 	Fan

6.3 Calibration Intervals

Calibration interval	Calibration	Calibration point
12 months	<ul style="list-style-type: none"> NGMO (see chapter 7) 	See page 2-1



6.4 Cleaning

The following devices and materials are recommended for cleaning the Power Supply NGMO:

- soft, lint-free cloths



Attention!

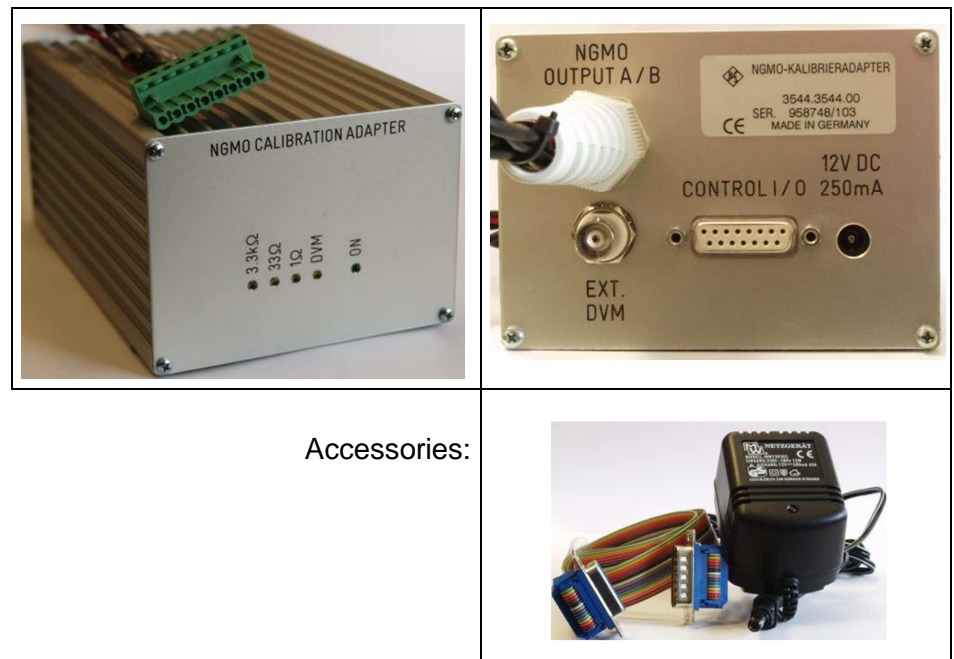
Do not use aggressive cleaning agents to clean the Power Supply NGMO.

7 Calibration

7.1 Calibration Equipment

Pos. No.	Test equipment	Technical data	Supplier	Part number
1	Calibration adapter	-	Rohde & Schwarz Cologne	3544.3544.00
2	15pin D-Sub plug/plug interface cable	Scope of delivery of the calibration adapter	Rohde & Schwarz Cologne	-
3	Digital voltmeter	Accuracy: 0.001 %	-	-

7.1.1 Calibration Adapter



Accessories:

Fig. 7-1 Calibration adapter

NOTE:



The calibration adapter is an option available on request.

7.2 Calibration Set-up

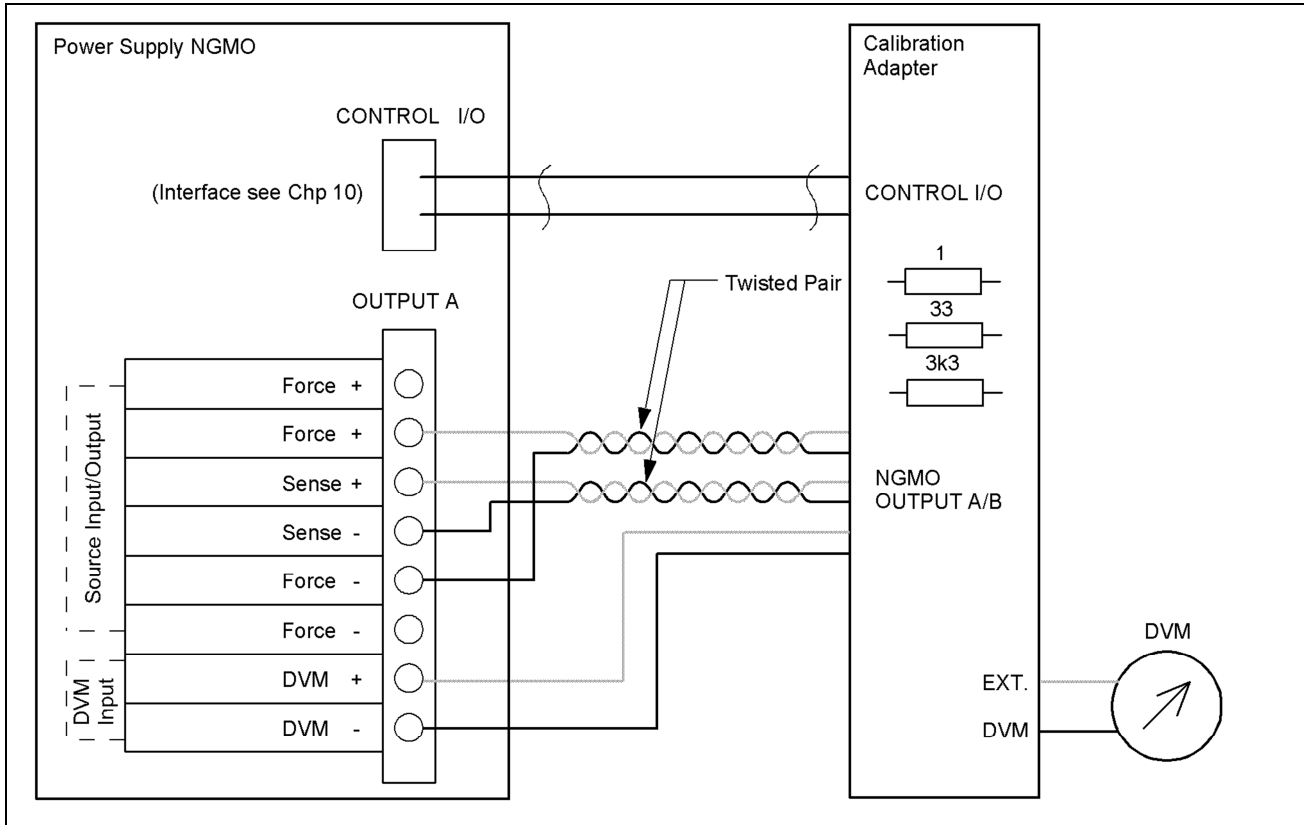


Fig. 7-2 Power Supply NGMO, Calibration set-up

7.3 Calibration Procedure

In the following you are taken through the complete calibration procedure for one of the power supply channels.

**NOTE:**

The NGMO must be switched on one hour before the calibration process in order to reach the correct operating temperature.

**NOTE:**

The following process describes the calibration for channel A.

1. Prepare the test set-up as shown in Fig. 7-2.
2. Switch on NGMO acc. to section 5.3, DVM and Calibration adapter.
3. Press key **CHN** to switch to channel A.

The display must show the following:

**AS: x.xxxV y.yyyA
A:OFF**

4. Press key **MENU**.
5. Turn rotary knob **VARIATION** to select menu option A38.
6. Press **ENTER**.

The display must show the following:

Press ENTER for next step

7. Press **ENTER**.



The display must show the following:

**Firmw.:x.yy CAL:zzzz
Lst CAL on: yy.mm.dd**

- **x.yy is the firmware version currently loaded in the NGMO.**
x is the major version number and yy is the minor version number.
- **zzzz: is the calibration counter. This counter is incremented by one every time a calibration has been successfully completed. Each channel has its own calibration counter.**
- **yy.mm.dd is the date of the last calibration for the selected channel.**
yy specifies the calibration year, mm is the calibration month, dd is the calibration day.

8. Press **ENTER**.

The display must show the following:

**Enter calibration
entry ID:**



NOTE:

The calibration entry ID is identical for both channels.

The calibration entry ID is a number not longer than 8 digits which acts as a password when you enter the real calibration functions. The default factory ID is: 0.

After the correct number on the numerical keys has been entered the NGMO enters the real calibration functions.

**Input of a new Entry ID**

Next, you are asked for a new calibration entry ID. If you want to set a new ID you can enter it here. After verification this new entry ID is stored internally in the NGMO. Next time you must use this new number to enter the calibration mode.

If you do not want to change the calibration entry ID, just press the SHIFT key instead of entering a number.

**NOTE:**

When using the calibration set-up specified in section 7.2, the following display may be neglected.

After entering the Entry ID the display should show the following:

**Remove all loads and
and connect cal. Adapter**

9. Press **ENTER**.

**NOTE:**

When using the calibration set-up specified in section 7.2, the following display may be neglected.

The display must show the following:

**on output terminal:A
Connect digital DVM**

10. Press **ENTER**.

The display must show the following:

**Look at DVM and ent.
Read value: xx mV**



11. Enter the **Measuring value**.

Use either the variation knob or numerical entry keys (press shift key to initiate the numerical input) to enter the measured value that is displayed on the DVM.

12. Press **ENTER**.

The display must show the following:

**Look at DVM and ent.
Read value: xx.yyy V**

13. Enter the **Measuring value**.

Use either the variation knob or numerical entry keys to enter the measured value that is displayed on the DVM.

14. Press **ENTER**.



NOTE:

When using the calibration set-up specified in section 7.2, the following display may be neglected.

The display must show the following:

**Connect known 1 Ohm
Resistor to out.term**

15. Press **ENTER**.

The display must show the following:

**Enter exact Resistor
value: x.xxxx Ohms**



NOTE:

The values of the resistors installed in the calibration adapter can be taken from the calibration certificate supplied with the calibration adapter.

16. Enter the resistance value.

Use either the variation knob or numerical entry keys to enter the exact resistor value.

17. Press **ENTER**.

**NOTE:**

When using the calibration set-up specified in section 7.2, the following display may be neglected.

The display must show the following:

**Connect known 33 Ohm
Resistor to out.term**

18. Press **ENTER**.

The display must show the following:

**Enter exact Resistor
value: 3x.xxx Ohms**

**NOTE:**

The values of the resistors installed in the calibration adapter can be taken from the calibration certificate supplied with the calibration adapter.

19. Enter the **resistance value**.

Use either the variation knob or numerical entry keys to enter the exact resistor value.

20. Press **ENTER**.

**NOTE:**

When using the calibration set-up specified in section 7.2, the following display may be neglected.



The display must show the following:

**Conn. Known 3.3 Kohm
Resistor to out.term**

21. Press **ENTER**.

The display must show the following:

**Enter exact Resistor
value: 3xxx.x Ohms**



NOTE:

The values of the resistors installed in the calibration adapter can be taken from the calibration certificate supplied with the calibration adapter.

22. Enter the **resistance value**.

Use either the variation knob or numerical entry keys to enter the exact resistor value.

23. Press **ENTER**.

The display must show the following:

**Remove cal. adapter
from output term.:A**

24. Press **ENTER**.



The display must show the following:

**Enter new CAL. Date:
YY/MM/DD: yy/mm/dd**

- **yy** is the current year (from 01 to 99).
- **mm** is the current month (from 01 to 12)
- **dd** is the current day (from 01 to 31 – depends on the selected month):

25. Enter the **Date**.

Use the variation knob and the arrow keys to enter the current date.

The display must show the following:

**Calibration success-
fully completed!**

The calibration procedure must be repeated for the other channel (NGMO2 only). This can be done in the following way.

26. Connect calibration adapter to output terminal B.
27. Press the “CHN A/B/DVM” key once. (Channel B).
28. Select Menu Item B38.
29. Repeat all the other steps listed above.



7.4 The Calibration Entry ID got lost



NOTE:

Only personnel authorized by ROHDE & SCHWARZ may open the NGMO.

If the safety regulations for the Power Supply NGMO are disregarded, ROHDE & SCHWARZ GmbH & Co KG will not assume liability for any resulting damage and all warranties will become null and void.

If the calibration entry ID is lost, it is possible to set the ID to zero. The following procedure describes how to enter 0 as the entry ID for new access to the calibration mode.



NOTE:

The following procedure voids your calibration certificate if it is from Rohde & Schwarz.

1. Switch off the NGMO and remove all connectors from the NGMO including the power cord.
2. Remove the four screws in the rear feet of the NGMO. (see section 9.1.1)
3. Remove the main shielding.



ELECTROCUTION HAZARDS!

The next steps expose you to hazardous voltages. Proceed with care.

Observe the relevant safety regulations relating to the operation of electrical devices.

4. Locate the two jumper pins on the bottom circuit board of the NGMO. These pins can be found near Pin 36 on micro controller chip SAB167CR-LM.
5. Short these two pins using a standard jumper.
6. Apply mains power to the NGMO and switch on the device.



After a short time, the NGMO displays the following message:

**Really set cal.entry
ID to 0. (ENTER=YES)**

Press **ENTER**.

If you press the **ENTER** key, the current calibration entry ID will be overwritten with a zero. Any other key aborts this function.

7. Remove the calibration entry ID jumper.
8. Switch off the NGMO and remove the power cord.
9. Replace the main shielding on the device and mount the four feet to the rear of the device. (see section 9.2.5)



8 Repair



NOTE:

The following sections describe some function tests using the Power Supply NGMO2 as an example.

This version is equipped with analog boards A and B.

The function tests also apply for NGMO1, in which case the tests are limited to analog board A.

All descriptions and specifications concerning channel B must be ignored.

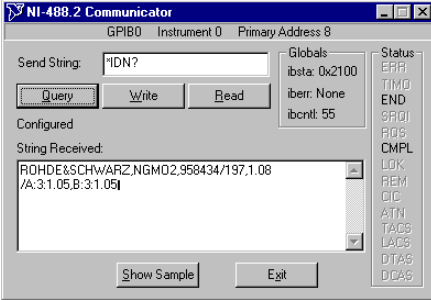
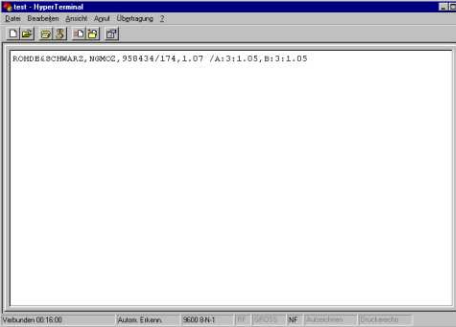
8.1 Function Tests by using the Service Functions

Power Supply NGMO (Vers. 1.00) has the following service functions integrated, which can be called up via special IEEE or serial commands (COM).

These service functions are on the one hand used to test the installed interfaces, and on the other to test the following functions and assemblies and to make the following adjustments:

- Set electronic serial number
- Set NGMO device name
- Communication test with analog boards
- Display blank test
- Display unblank test
- Keyboard and knob test
- Control I/O test
- INHIBIT ON test
- Switch off test functions

8.1.1 Selecting the Interfaces to be used

IEEE-488-2 Interface	COM Interface:
	
National NI-488-2 Communicator	<p>If the serial interface is used, this should be manually set to „ON“, under menu option 31, beforehand. Apart from that the serial interface parameters must be adapted to the parameters of the controlling computer.</p> <p>Hyper terminal</p>

All service commands start with the character string:

"rus:service:...".

These are specific for the service and should therefore be treated confidentially.

The following sections specify the additional commands, which were implemented in addition to the standard commands.



8.1.2 Setting the Electronic Serial Number

Function test	<p>The electronic serial number is stored in the EEPROM of the Power Supply NGMO.</p> <ul style="list-style-type: none">• Read out the serial number with the following remote command: *IDN?
Fault rectification	<p>In case of an occurring fault:</p> <ul style="list-style-type: none">• Reprogram the serial number.
Setting, input	<p>After replacing the processor board this replacement board must be reprogrammed to the serial number of the unit (located on the back of the unit).</p> <ul style="list-style-type: none">• Enter the serial number using the following remote command: rus:service:set:device:serial:number "SERIAL_NUMBER_STRING" <p>Instead of the: SERIAL_NUMBER_STRING you must enter the serial number of the unit, as it is printed on the back of the unit. Quotation marks (") must also be entered.</p>



8.1.3 Setting the NGMO Device Name (from firmware version 1.10)

Function test	<p>The device name is stored in the EEPROM of the Power Supply NGMO.</p> <ul style="list-style-type: none">• Read out the serial number with the following remote command: *IDN?
---------------	---

Fault rectification	<p>In case of an occurring fault:</p> <ul style="list-style-type: none">• Reprogram the device name.
---------------------	--

Setting, input	<p>After replacing the processor board the device name must be reprogrammed, if the name displayed when switching on does not match the designation on the front panel.</p> <ul style="list-style-type: none">• Enter the device name using the following remote command: rus:service:set:ngmo:name "NGMO-NAME" <p>Instead of "NGMO-NAME", enter the device name (e.g. "NGMO2"), as printed on the front panel of the unit. Quotation marks (") must also be entered.</p>
----------------	--



8.1.4 Communication Test with Analog Boards

Description	The following remote commands can be used to test whether the communication between the main computer on the processor board and the two satellite computers on the analog boards works correctly. For this purpose a test number can be transmitted to one of the two satellite computers, which can subsequently be read back in a second step.
-------------	---

8.1.4.1 Commands for channel: A

Function test	<ul style="list-style-type: none">Send the test number with the following remote command to the NGMO: rus:a:service:slave:comm:test NUMBER <p>The test number may be any number between 0 and 65535.</p> <ul style="list-style-type: none">Read out the test number with the following remote command: rus:a:service:slave:comm:test?
---------------	---

Fault rectification	<ul style="list-style-type: none">If an error occurs:Replace the analog board as described in chapter 9 orreplace the processor board as described in chapter 9.
---------------------	--

8.1.4.2 Commands for channel: B

Function test	<ul style="list-style-type: none">Send the test number with the following remote command to the NGMO2: rus:b:service:slave:comm:test NUMBER <p>The test number may be any number between 0 and 65535.</p> <ul style="list-style-type: none">Read out the test number with the following remote command: rus:b:service:slave:comm:test?
---------------	--

Fault rectification	<ul style="list-style-type: none">If an error occurs:Replace the analog board as described in chapter 9 orreplace the processor board as described in chapter 9.
---------------------	--



8.1.5 Display Blank Test

Description	This test is performed to determine whether all pixels of the LC display can be switched off. After initiating the test the LC display should not show any pixels.
-------------	--

Function test	<ul style="list-style-type: none">• Switch off all pixels of the LC display using the following remote command: rus:service:select:function:test 1• Interrogate test 1: rus:service:select:function:test? <p>The second command (interrogation command) is used to determine whether the test was successfully completed. The interrogation command will keep on returning 65535, until the user either presses the <i>ENTER</i> – key, or any other key on the unit.</p> <p>ENTER:</p> <ul style="list-style-type: none">• The display shows the following message: <div data-bbox="691 1187 1161 1305" style="border: 1px solid black; padding: 5px; margin: 10px auto; width: fit-content;"><p>User Input: Test: OK!</p></div> <p>The interrogation command returns 0.</p> <p>Any other key:</p> <ul style="list-style-type: none">• The display shows the following message: <div data-bbox="691 1541 1161 1659" style="border: 1px solid black; padding: 5px; margin: 10px auto; width: fit-content;"><p>User Input: Test: FAILED!</p></div> <p>The interrogation command returns 1.</p>
---------------	--

Fault rectification	<ul style="list-style-type: none">• If an error occurs:• Replace the keyboard as described in chapter 9 or• replace the processor board as described in chapter 9.
---------------------	--



8.1.6 Display Unblank Test

Description	This test is performed to determine whether all pixels of the LC display can be switched on. After starting this test the LC-display should show grey blocks with all pixels in place.
-------------	--

Function test	<ul style="list-style-type: none">• Switch on all pixels of the LC display using the following remote command: rus:service:select:function:test 2• Interrogate test 2: rus:service:select:function:test? <p>The second command (interrogation command) is used to determine whether the test was successfully completed. The interrogation command will keep on returning 65535, until the user either presses the <i>ENTER</i> – key, or any other key on the unit.</p> <p>ENTER:</p> <ul style="list-style-type: none">• The display shows the following message: <div data-bbox="783 1189 1254 1308" style="border: 1px solid black; padding: 5px; margin: 10px auto; width: fit-content;"><p>User Input: Test: OK!</p></div> <p>The interrogation command returns 0.</p> <p>Any other key:</p> <ul style="list-style-type: none">• The display shows the following message: <div data-bbox="783 1543 1254 1662" style="border: 1px solid black; padding: 5px; margin: 10px auto; width: fit-content;"><p>User Input: Test: FAILED!</p></div> <p>The interrogation command returns 1.</p>
---------------	---

Fault rectification	<ul style="list-style-type: none">• If an error occurs:• Replace the keyboard as described in chapter 9 or• replace the processor board as described in chapter 9.
---------------------	--



8.1.7 Keyboard and Knob Test

Description	This test enables the user to check whether all keyboard keys and the rotary transducer work correctly.
-------------	---

Function test	<p>After starting operate the rotary transducer first.</p> <p>When turning clockwise the numerical value in top right hand corner of the display must increase by 1 with every step of the rotary transducer, and decrease by 1 when turning anti-clockwise.</p> <p>After this all keys must be pressed.</p> <p>Instead of the respective grey blocks the corresponding numerical value should be displayed, when pressing the SHIFT- and ENTER-keys the words "SHIFT" and "ENTER" and in case of the arrow keys the corresponding arrow symbol should appear.</p> <p>When pressing one of the keys again, the corresponding field is displayed again in grey.</p> <ul style="list-style-type: none"> Switch on test 3 with the following remote command: rus:service:select:function:test 3 The display shows the following message: <div data-bbox="691 1283 1161 1406" style="border: 1px solid black; padding: 5px; margin: 10px 0;"> <p>Keyboard/Knob-Test Press every key</p> </div> <p>After this grey blocks appear in the display.</p> <p>Press all keys and operate the rotary transducer (see above):</p> <ul style="list-style-type: none"> The display shows the following message: <div data-bbox="691 1637 1161 1760" style="border: 1px solid black; padding: 5px; margin: 10px 0;"> <p>User Input: Test: OK!</p> </div> Interrogate test 3: rus:service:select:function:test? <p>This interrogation command is used to determine whether the test was successfully completed. The interrogation command first returns 65535.</p>
---------------	--

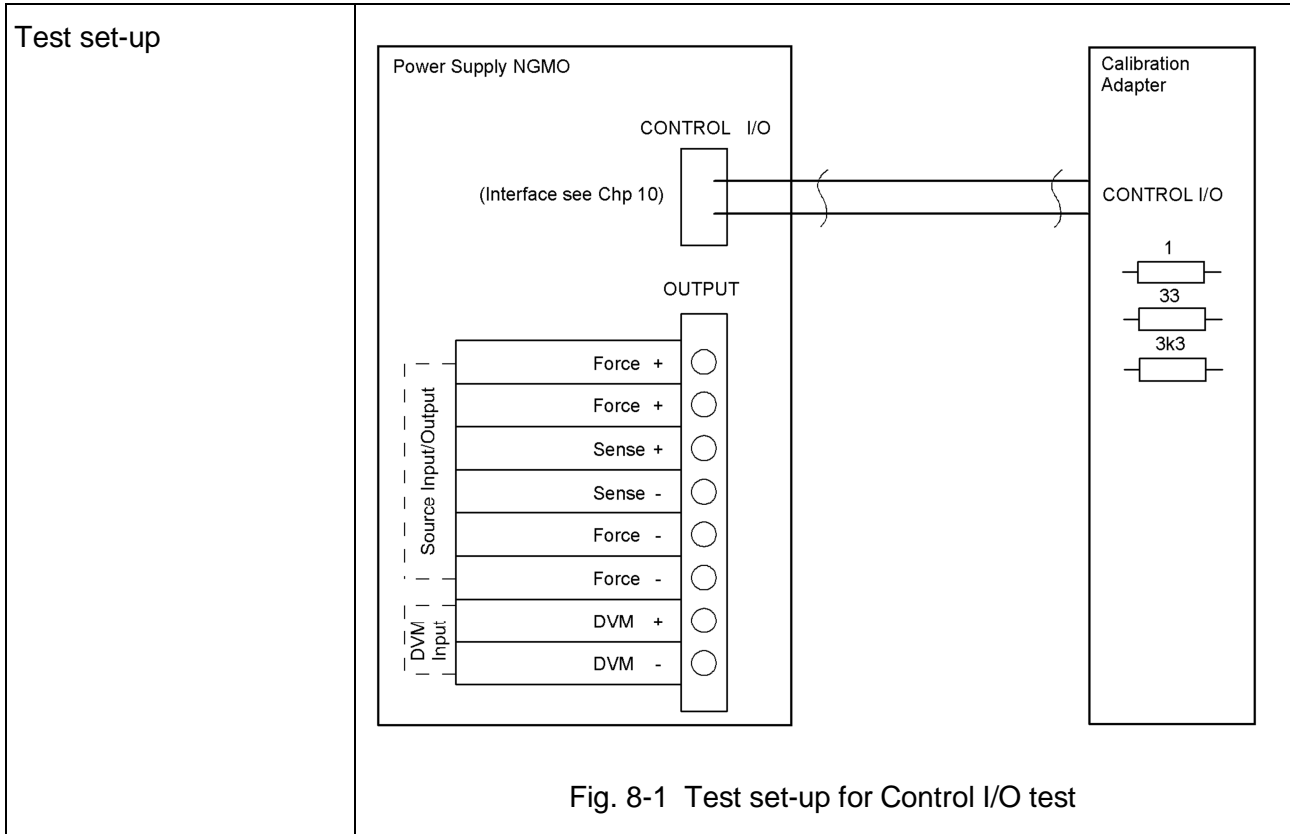


	<p>The following bits are set to 0 when:</p> <table><tr><td>Turning rotary transducer anti-clockwise</td><td>Bit 15</td></tr><tr><td>Turning rotary transducer clockwise</td><td>Bit 14</td></tr><tr><td>Right hand arrow key</td><td>Bit 13</td></tr><tr><td>Left hand arrow key</td><td>Bit 12</td></tr><tr><td>ENTER key</td><td>Bit 11</td></tr><tr><td>SHIFT key</td><td>Bit 10</td></tr><tr><td>RECALL (9) key</td><td>Bit 9</td></tr><tr><td>OCP (8) key</td><td>Bit 8</td></tr><tr><td>I-SET (7) key</td><td>Bit 7</td></tr><tr><td>OUTP. ON/OFF (6) key</td><td>Bit 6</td></tr><tr><td>MENU (5) key</td><td>Bit 5</td></tr><tr><td>SAVE (4) key</td><td>Bit 4</td></tr><tr><td>OVP (3) key</td><td>Bit 3</td></tr><tr><td>U-SET (2) key</td><td>Bit 2</td></tr><tr><td>CHN/A/B/DVM (1) key</td><td>Bit 1</td></tr><tr><td>LOCAL (0) key</td><td>Bit 0</td></tr></table> <p>If the rotary transducer is turned anti-clockwise and clockwise while all keys are pressed, the value 0 will finally be returned.</p>	Turning rotary transducer anti-clockwise	Bit 15	Turning rotary transducer clockwise	Bit 14	Right hand arrow key	Bit 13	Left hand arrow key	Bit 12	ENTER key	Bit 11	SHIFT key	Bit 10	RECALL (9) key	Bit 9	OCP (8) key	Bit 8	I-SET (7) key	Bit 7	OUTP. ON/OFF (6) key	Bit 6	MENU (5) key	Bit 5	SAVE (4) key	Bit 4	OVP (3) key	Bit 3	U-SET (2) key	Bit 2	CHN/A/B/DVM (1) key	Bit 1	LOCAL (0) key	Bit 0
Turning rotary transducer anti-clockwise	Bit 15																																
Turning rotary transducer clockwise	Bit 14																																
Right hand arrow key	Bit 13																																
Left hand arrow key	Bit 12																																
ENTER key	Bit 11																																
SHIFT key	Bit 10																																
RECALL (9) key	Bit 9																																
OCP (8) key	Bit 8																																
I-SET (7) key	Bit 7																																
OUTP. ON/OFF (6) key	Bit 6																																
MENU (5) key	Bit 5																																
SAVE (4) key	Bit 4																																
OVP (3) key	Bit 3																																
U-SET (2) key	Bit 2																																
CHN/A/B/DVM (1) key	Bit 1																																
LOCAL (0) key	Bit 0																																

Fault rectification	<ul style="list-style-type: none">• If an error occurs:• Replace the keyboard as described in chapter 9 or• replace the processor board as described in chapter 9.
---------------------	--

8.1.8 Control I/O Test

Description	The Control I/O test checks the functionality of the signals on the “Control I/O” plug on the back NGMO. For this purpose the NGMO calibration adapter must be connected as shown in Fig. 8-1 for the following test:
-------------	---





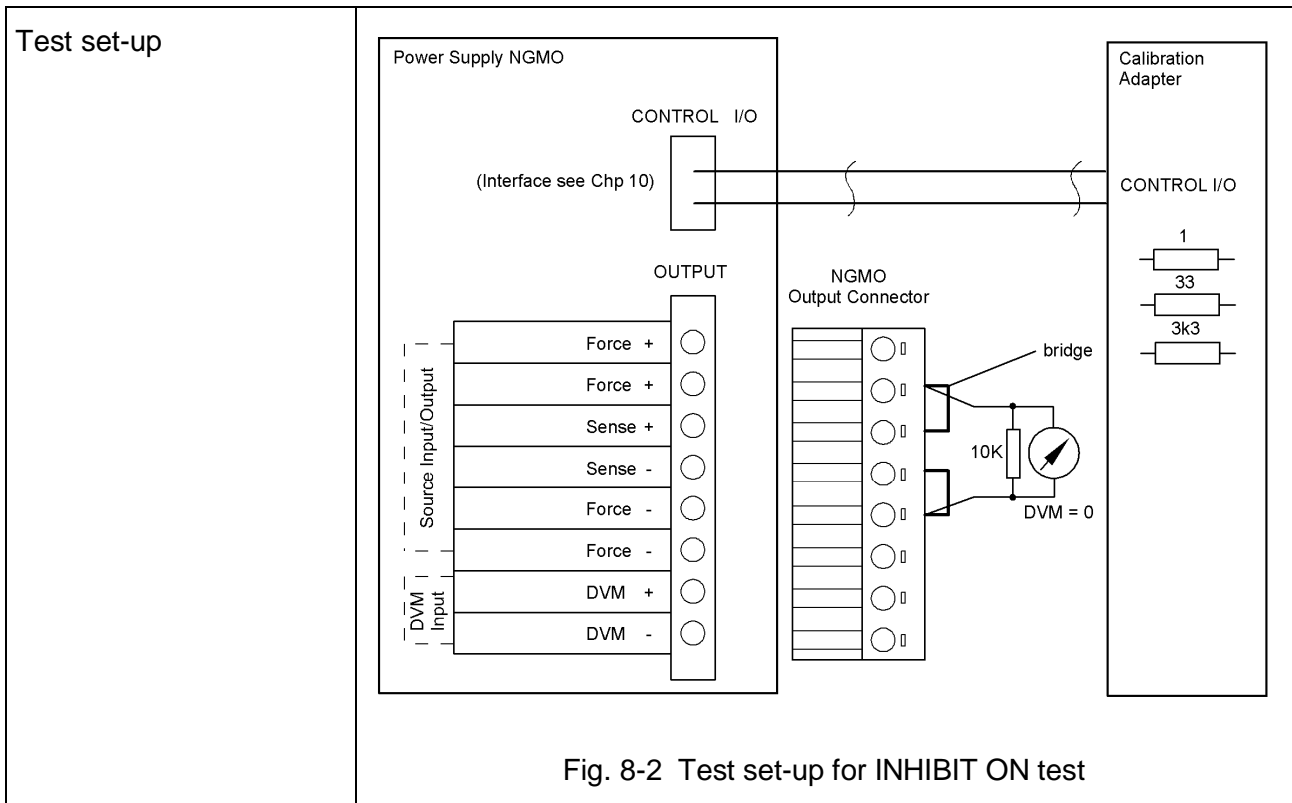
Function test	<ul style="list-style-type: none">• Switch on test 4 with the following remote command: rus:service:select:function:test 4• The display shows the following message: <div data-bbox="783 474 1254 595" style="border: 1px solid black; padding: 5px; text-align: center;">Control I/O test OK!</div>• Interrogate test 4: rus:service:select:function:test? <p>If no error is present, the returned value of the function should be 0.</p>
---------------	---

Function test	<p>The following bits are set when:</p> <p>Slave I/O fault channel B Bit 9 Slave I/O fault channel A Bit 8 Relay4/TRIGG_A fault Bit 3 Relay3/INHIB_A fault Bit 2 Relay2/TRIGG_B fault Bit 1 Relay1/INHIB_B fault Bit 0</p>
---------------	--

Fault rectification	<ul style="list-style-type: none">• In case of an occurring fault:• replace the processor board as described in chapter 9.
---------------------	---

8.1.9 INHIBIT ON

Description	<p>This function is used to test whether the output drivers of the NGMO can be switched off via the Inhibit lines.</p> <p>This requires the following test set-up.</p>
-------------	--



<p>Test equipment</p> <p>Fig. 8-3 NGMO Output plug (2 pcs.)</p>	<p>Plug both MGMO output plugs (see chapter 11) onto the two outputs of the NGMO2, Output A and Output B.</p> <p>The following connections (see photo opposite) must be available on the NGMO output plug:</p> <p>Force + with Sense + and Force - with Sense -.</p>
---	--



Function test	<p>Set any output voltages on channels A and B. Switch both outputs to ON (see section 5.1).</p> <ul style="list-style-type: none">• Switch on test 5 with the following remote command: Rus:service:select:function:test 5• The display shows the following message: <div data-bbox="783 577 1254 696" style="border: 1px solid black; padding: 5px; text-align: center;">Inhibit ON test all outputs OFF</div><ul style="list-style-type: none">• Interrogate test 5: rus:service:select:function:test? <p>The return value of this function is always 0.</p> <p>On both outputs A and B 0 V must be applied to Force +/Force - (see Fig. 8-2).</p>
Fault rectification	<ul style="list-style-type: none">• In case of an occurring fault:• Replace the analog board as described in chapter 9 or• replace the processor board as described in chapter 9.• Check the calibration adapter.



8.1.10 Switching off Test Functions

The following function switches the test functions off again. The NGMO is again ready for normal use.

- Switch off the test functions with the following remote command:

Rus:service:select:function:test 0

The Power Supply NGMO returns to its initial state.



8.2 Error Messages in the Display

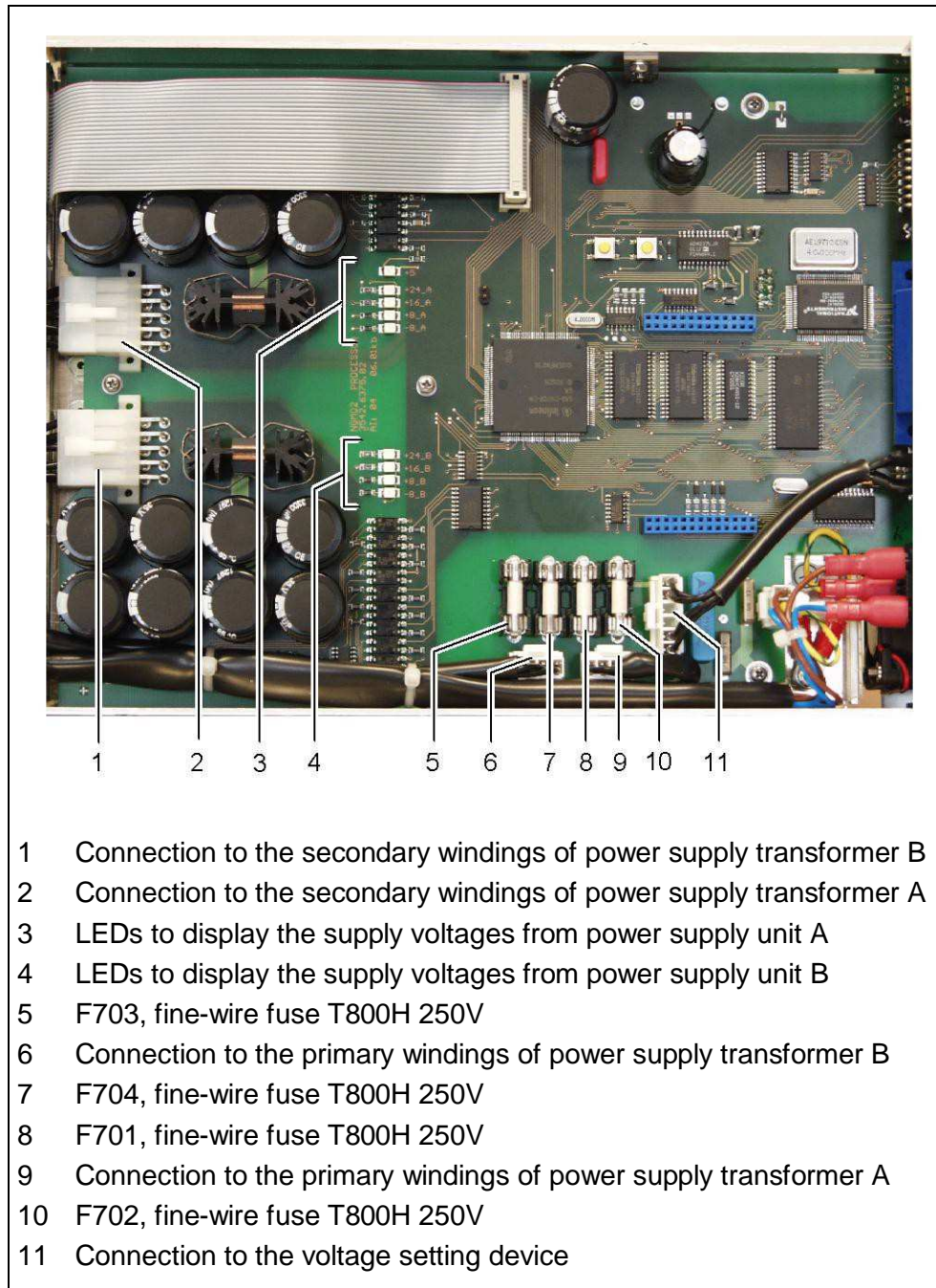
The following list shows all error messages that could occur during operation of the NGMO and which indicate a malfunction of the unit.

The list does not show any messages which may occur during normal operation.

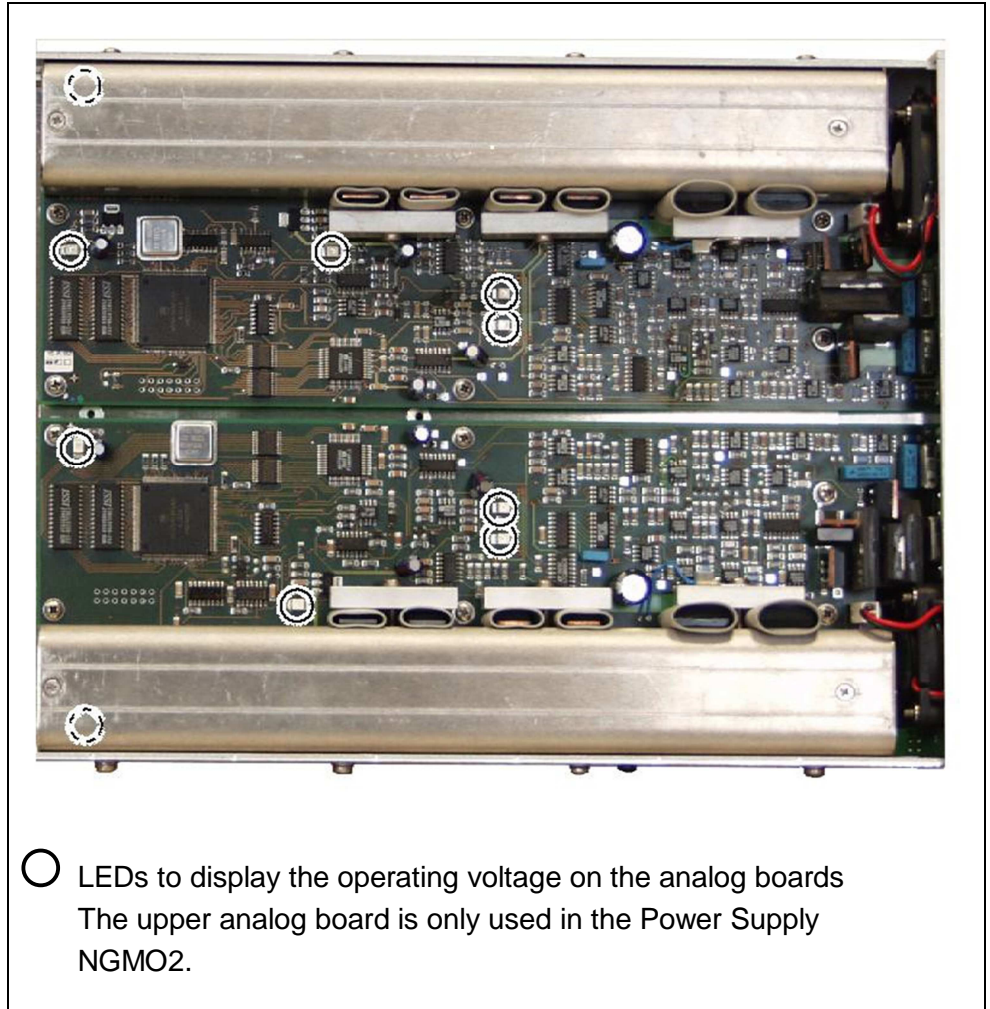
Display	Description of error	Defective module
FATAL internal error RAM test failed!	This message is displayed if the self-test of the internal RAM on the processor board responds with an error.	Processor board
FATAL internal error FLASH test failed!	This message is displayed if the self-test of the internal Flash-Memory on the processor board responds with an error.	Processor board The error can possibly be rectified by reprogramming the NGMO firmware. (see chapt. 12)
FATAL internal error Inval. analog program	This message is displayed if a checksum error has occurred in the program for the DSP on the analog board.	Processor board The error can possibly be rectified by reprogramming the NGMO firmware. (see chapt. 12)
FATAL internal error Selftest CHN: A FATAL internal error Selftest CHN: B	These messages are displayed if one of the DSPs on the analog board reports a self-test error.	Analog board A or B Communication with the analog board is disturbed, i.e. in very rare instances the error may be caused by the processor board.
Read ERROR CHN: A Read ERROR CHN: B	These errors may occur if communication with the analog board is interrupted during operation.	This error is most likely caused by the corresponding analog board. But may also be caused by the processor board.
Read ERROR DVMA Read ERROR DVMB	These errors may occur if communication with the analog board is interrupted during operation.	This error is most likely located on the corresponding analog board. But may also be caused by the processor board.

8.3 Checking the Output Voltages

8.3.1 Processor Board



8.3.2 Analog Boards






8.4 General Troubleshooting

Type of fault	Fault diagnose	Fault rectification
NGMO2 does not deliver output voltage on both channels	<ul style="list-style-type: none">• Fuse blown by overvoltage at the power supply input.• LEDs for operating voltage on processor board do not light (see section 8.3.1).• Fault still present.	<ul style="list-style-type: none">• Replace defective fuses.• Replace processor board as described in section 9.1.4.• Return the NGMO2 to the Support Service Centre (see chapter 2).
NGMO does not deliver output voltage on one channel	<ul style="list-style-type: none">• On one power supply unit the corresponding fuses have been blown by overvoltage at the power supply input.• LEDs for operating voltage assigned to one of the mains supply units on the processor board do not light (see section 8.3.1).• LEDs for operating voltage on one of the processor boards do not light (see section 8.3.1).• Fault still present.	<ul style="list-style-type: none">• Replace defective fuses.• Replace processor board as described in section 9.1.4.• Replace the corresponding analog board as described in section 9.1.2.• Return the NGMO2 to the Support Service Centre (see chapter 2).

9 Removal and Installation of Assemblies

	<p>ELECTROCUTION HAZARDS!</p> <p>Disconnect the unit from the mains supply before opening the housing.</p>
---	---

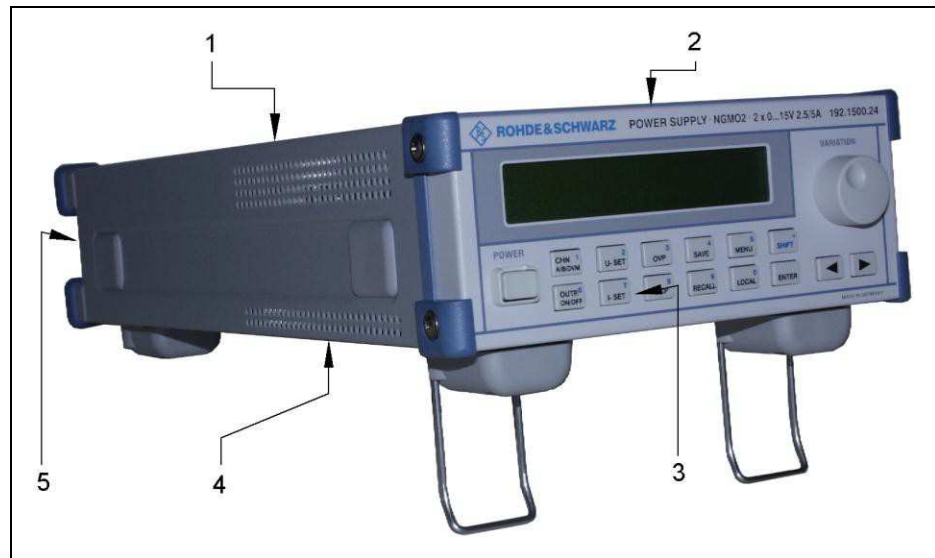


NOTE:

The following sections describe the procedures for removing and installing assemblies using the Power Supply NGMO2 as an example. This version is equipped with two analog boards (Channel A and Channel B).

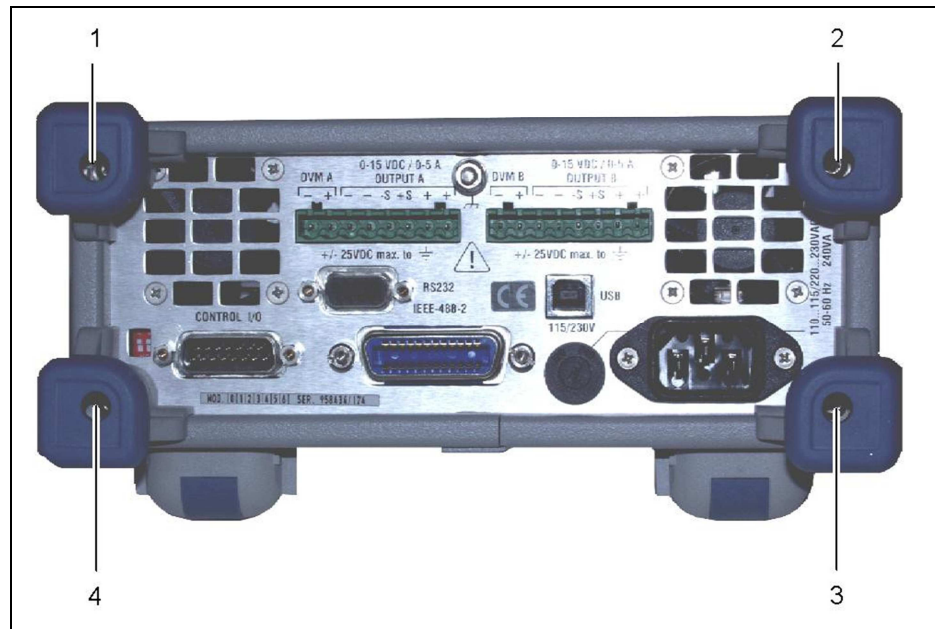
The instructions for removal and installation apply also for the NGMO1, in which case the removal and installation process is reduced to analog board Channel A. All descriptions and specifications concerning channel B must be ignored.

9.1 Removal of Assemblies



- 1 Analog board (Channel B) Y102
- 2 Analog board (Channel A) Y101
- 3 Keyboard Y202
- 4 Processor board Y301
- 5 Fan A, B

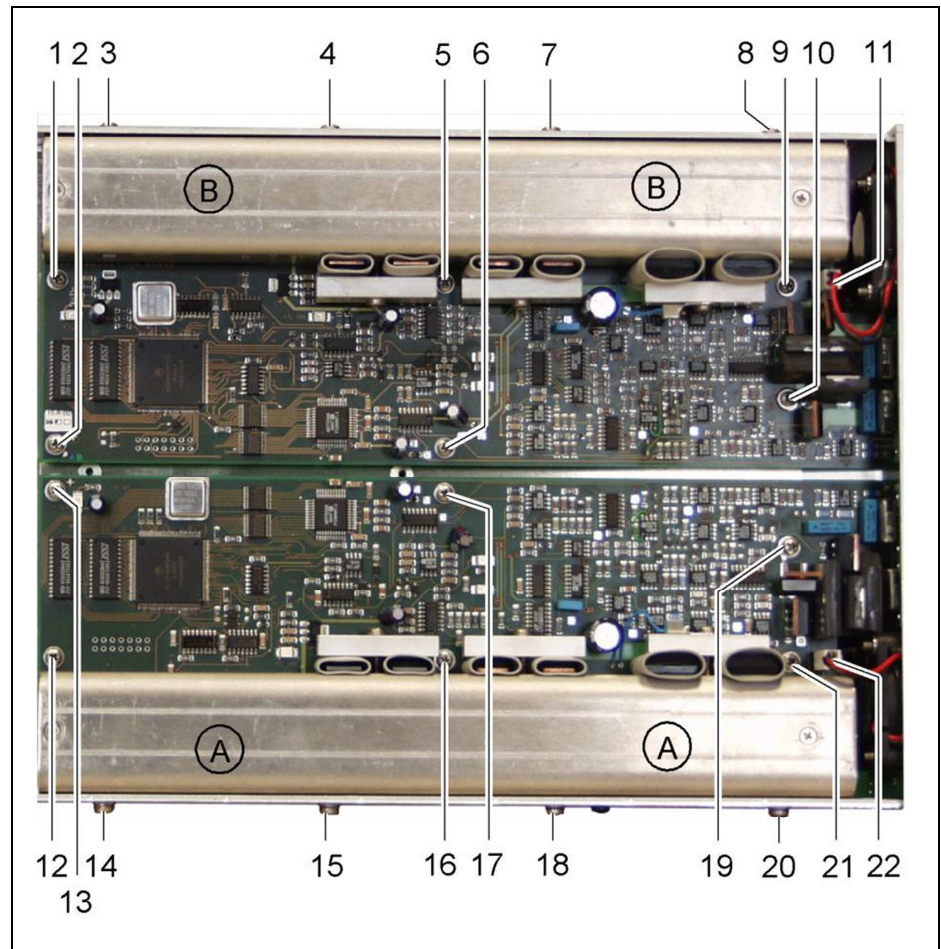
9.1.1 Removing the Housing



1. Unscrew the screws from the rear (1, 2, 3, 4) and pull the housing off to the rear.

A TORX screwdriver TX 20 is required.

9.1.2 Removing of the Analog Board Y101, Y102



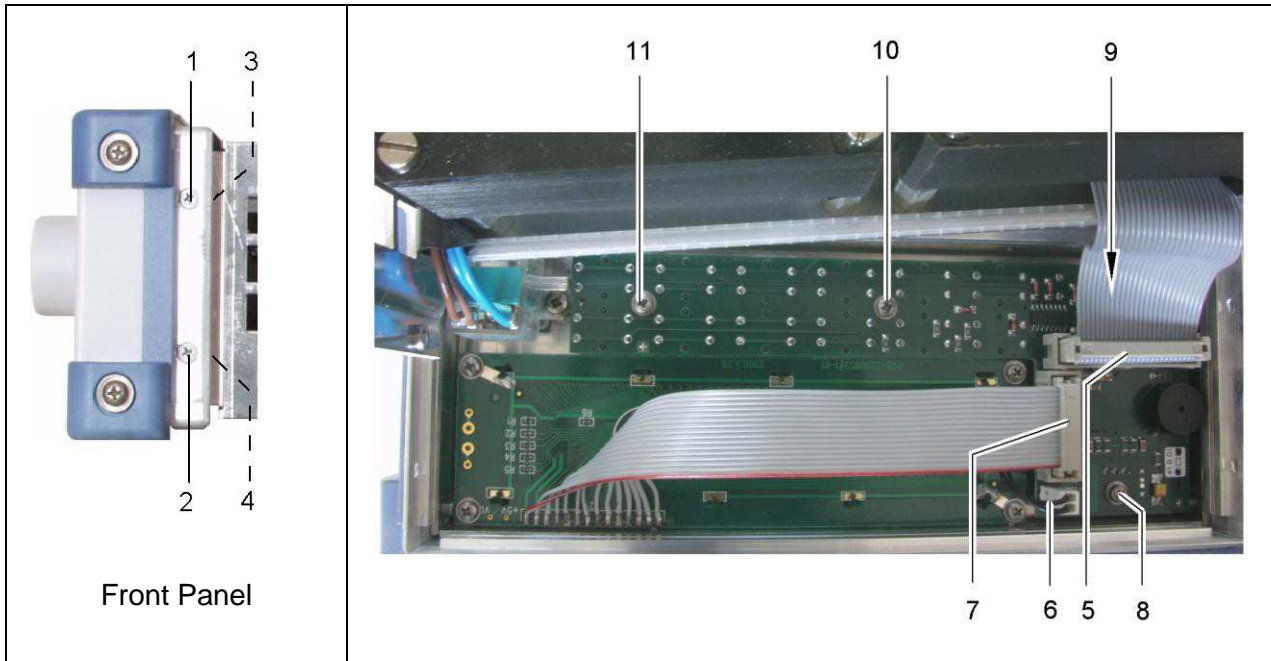
9.1.2.1 Analog board Y101 (Channel A)

1. Pull off plug X501 (22) for fan A.
2. Unscrew the screws of analog board Y101 (Channel A) (12 to 21).
3. Remove the board.

9.1.2.2 Analog board Y102 (Channel B)

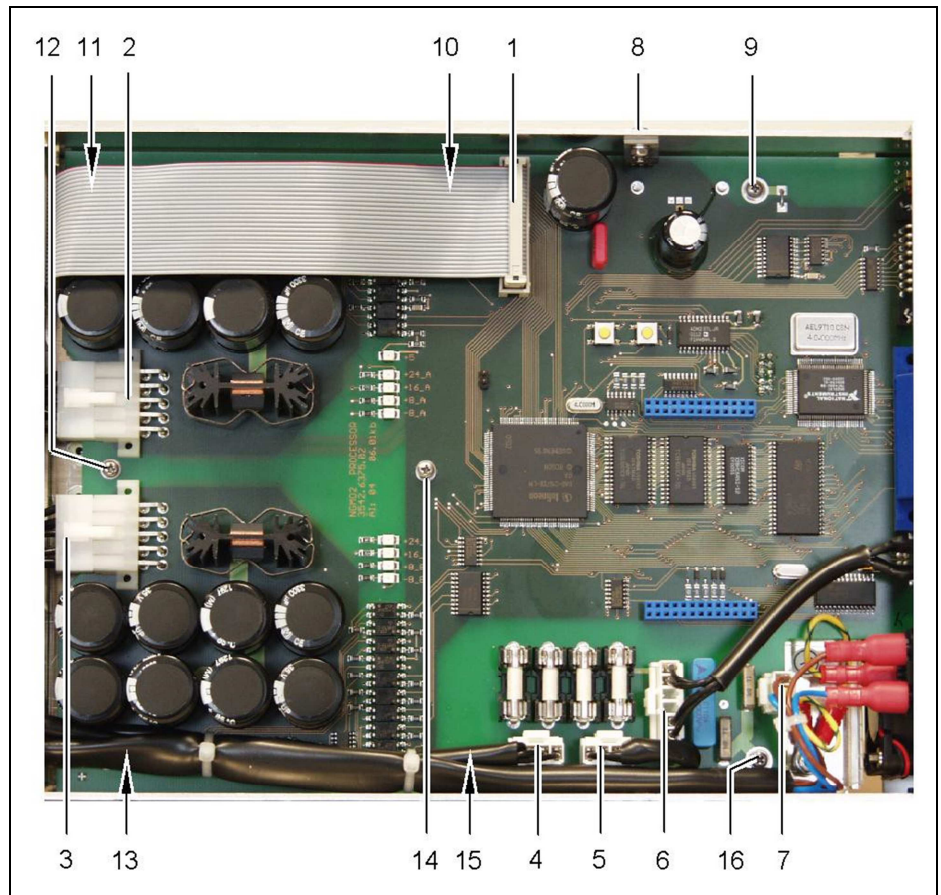
1. Pull off plug X501 (11) for fan B.
2. Unscrew the screws of analog board Y102 (Channel B) (1 to 10).
3. Remove the board.

9.1.3 Removing of Keyboard Y202

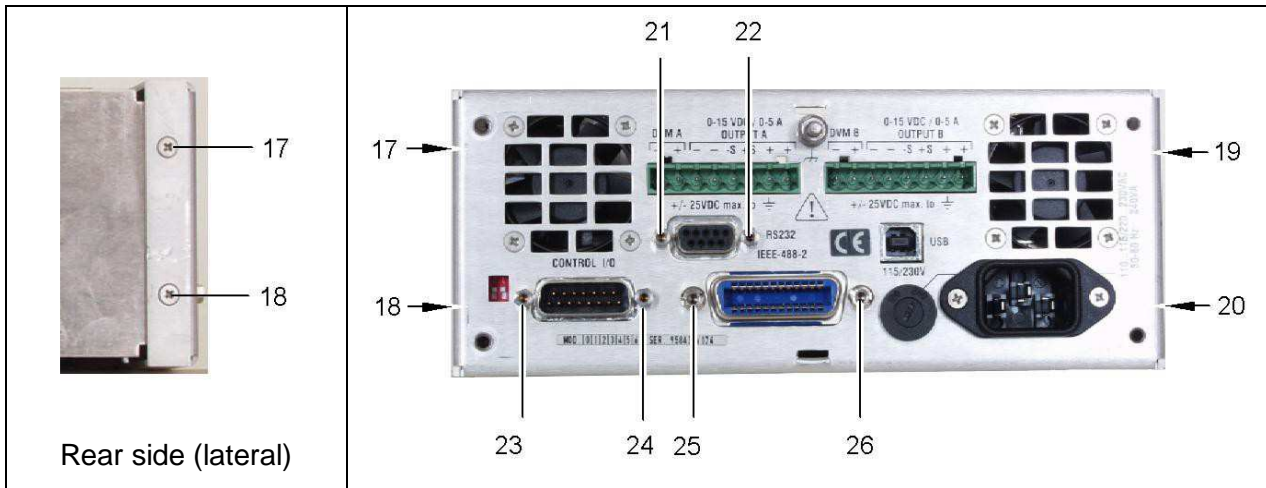


1. Unscrew the screws on the front panel (1, 2, 3, 4).
2. Fold the front panel carefully down.
3. Pull off plugs X101, X102 and X103 (5, 6, 7).
4. Unscrew the screws (8, 9, 10, 11).

9.1.4 Removing of Processor Board Y301




1. Pull off plugs X101 (1), X703 (2), X801 (3), X805 (4), X705 (5), X706 (6), X704 (7).
2. Unscrew screw (8) from the cooling plate of the LM2940CT.
3. Unscrew screws (9 to 16).



4. Unscrew the screws on both sides of the rear wall (17 to 20).
5. Unscrew the screws from *CONTROL I/O*, *IEEE-488-2* and *RS232* (21 to 26).
6. Fold the rear wall carefully down.
7. Take out the processor board

9.1.5 Removing of Fans A, B



1. To remove the fan, disassemble the corresponding analog board as described in section 9.1.2.
2. Unscrew the screws for the corresponding fan.
3. Pull the fan up to remove.

9.2 Installation of Assemblies

9.2.1 Installation of the Analog Boards Y101, Y102

For installation of the analog boards please refer to the illustrations in section 9.1.2.

9.2.1.1 Analog board Y101 (Channel A)

1. Carefully insert the board into the connection on the processor board.
2. Press the board slightly down at the points marked "A" and locate it with the four lateral screws (14, 15, 18, 20).
3. Fasten the board with the remaining screws (12 to 21).
4. Connect plug X501 (22) for fan A.

9.2.1.2 Analog board Y102 (Channel B)

1. Carefully insert the board into the connection on the processor board.
2. Press the board slightly down at the points marked "B" and locate it with the four lateral screws (3, 4, 7, 8).
3. Fasten the board with the remaining screws (1 to 10).
4. Connect plug X501 (11) for fan B.

9.2.2 Installation of the Keyboard Y202

For installation of the keyboard please refer to the illustrations in section 9.1.3.

1. Insert the keyboard into the front panel
2. Turn in screws (8, 9, 10, 11).
3. Connect plugs X101, X102 and X103 (5, 6, 7) to the board.
4. Fasten the front panel to the frame using screws (1, 2, 3, 4).

9.2.3 Installation of Processor Board Y301

For installation of the processor board please refer to the illustrations in section 9.1.4.



1. To install the processor board you must first remove both analog boards as described in section 9.1.2 to prevent damaging any plug connections on the analog boards.

2. Insert the processor board into the frame, align it to the fans and locate it with the screw (14).
3. Fasten the *RS232*-plug connection (21, 22) on the rear wall with screws.
4. Fasten the rear wall with screws (17 to 20) to the frame.
5. Fasten *CONTROL I/O*- and *IEEE-488-2* plug connections with screws (23 to 26) to the rear wall
6. Fasten the board with the remaining screws (9 to 16).
7. Connect plugs X101 (1), X703 (2), X801 (3), X805 (4), X705 (5), X706 (6), X704 (7) to the board.
8. Fasten the LM2940 CT cooling plate with screws (8) to the frame.

9.2.4 Installation of Fans A, B



The corresponding analog board must be removed before installing the fan.

1. Insert the fan from above.
2. Fasten the fan with screws.
3. Install the analog board as described in section 9.2.1.
4. Connect the fan cable to the analog board.

9.2.5 Assembling the Unit

To assemble the unit please refer to the illustrations in section 9.1.1.

1. Slide the housing over the frame and fasten with screws (1, 2, 3, 4) on the rear side.

10 Interfaces



NOTE:

The following section shows the Power Supply NGMO2. This version is equipped with two analog boards (Channel A and Channel B).

The NGMO1 is equipped with only one analog board (Channel A).

All descriptions and specifications concerning channel B must be ignored.

This chapter describes the non-standardized interfaces (in the picture surrounded by frames).

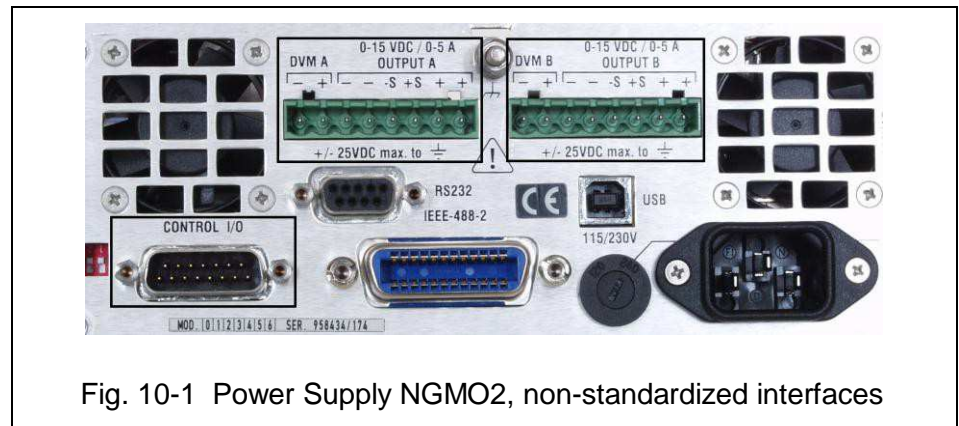


Fig. 10-1 Power Supply NGMO2, non-standardized interfaces



10.1 OUTPUT A / OUTPUT B (Channel A /Channel B)

Pin	Function	
1	DVM-	(input)
2	DVM+	(input)
3	FORCE-	(output)
4	FORCE-	(output)
5	SENSE-	(input)
6	SENSE+	(input)
7	FORCE+	(output)
8	FORCE+	(output)

10.2 CONTROL I/O (Relay Connector, SUB 15, Male)

Pin	Function	Signal	Wert
1	RELOUT 1	output, relay driver, open collector	28 VDC/200 mA max.
2	RELOUT 2	output, relay driver, open collector	28 VDC/200 mA max.
3	RELOUT 3	output, relay driver, open collector	28 VDC/200 mA max.
4	RELOUT 4	output, relay driver, open collector	28 VDC/200 mA max.
5	FAULT	output, fault signal, open collector	28 VDC/200 mA max.
6	NC	not used	not used
7	NC	not used	not used
8	GND	GND	signal GND
9	GND	GND	signal GND
10	INHIBIT_B	input, external inhibit signal	TTL 0 ... 12 VDC
11	TRIGGER_B	input, external inhibit signal	TTL 0 ... 12 VDC
12	INHIBIT_A	input, external inhibit signal	TTL 0 ... 12 VDC
13	TRIGGER_A	input, external inhibit signal	TTL 0 ... 12 VDC
14	COMPL_B	output, complete signal, open collector	28 VDC/200 mA max.
15	COMPL_A	output, complete signal, open collector	28 VDC/200 mA max.





11 Bill of Materials

Pos. No.	Test equipment	Technical data	Supplier	Part number
1	Processor board		Rohde & Schwarz, Cologne	5707.2459.02
2	Analog board (Channel A)		Rohde & Schwarz, Cologne	5707.2465.02
3	Analog board (Channel B)		Rohde & Schwarz, Cologne	5707.2488.02
4	Keyboard with LC Display		Rohde & Schwarz, Cologne	3544.3521.00
5	Fan (fan, cable and plug, prefabricated for installation)		Rohde & Schwarz, Cologne	5707.2288.00
6	Calibration adapter (incl. output-, control I/O-connecting cable and power supply unit)		Rohde & Schwarz, Cologne	3544.3544.00
7	NGMO Output Connector (2 units)	MSTB 2,5/8 ST-5,08 Phoenix Contact	RS-Components	5707.2320.00



12 Software Update

12.1 Components List

The following components are needed to update the NGMO firmware:

Pos. No.	Components	Part number
1	Computer with Windows 95/98/NT/2000/XP/Vista/7	-
2	9-pole serial 1:1 connecting cable (extension lead) (no null-modem cable)	-
3	Power Supply NGMO (Version x) (Rohde & Schwarz)	-
4	Update file: NGMO_xxx.ZIP	-

12.2 Running the Update

Perform the following procedures:



1. Switch on and boot the computer.
2. Copy NGMO_xxx.ZIP into its own directory.
3. Unpack NGMO2_xxx.ZIP using WINZIP or a similar program.
4. Press the two DIP switches on the rear side of the Power Supply NGMO (see photo left) carefully down with a flat screwdriver.
5. Use the 9-pole serial connecting cable to connect the serial (COM) interface of the computer to the RS232-interface of the Power Supply NGMO.
6. Switch on the Power Supply NGMO.
The unit may not respond with a switch-on message at this point. This is OK.

7. Open the *PROMPT* (command line window) on the computer and change to the directory containing the NGMO-Flash files.
8. Enter **DOWNLOAD 1** (for COM1) or **DOWNLOAD 2** (for COM2) into the command lines.

The entry above depends on the connection between Power Supply NGMO and the interface COM1 or COM2 on the computer.

The *PROMPT* shows, among others, the following message:

Wait erasing Flash Memory

and after a short while:

OK!

Thereafter appearing dots indicate the progress of the Flash programming.

After a successful download the Power Supply NGMO should respond again; this time by showing the version number:

x.xx

9. After a successful **DOWNLOAD** close the *PROMPT* again, as otherwise the serial interface used will remain blocked.
10. Switch both DIP switches behind the recess back up. (Do not forget)!

The Power Supply NGMO is now ready for operation.

