

PAGING AND DISPATCHING MICROPHONE**GENERAL**

The Shure Model 450 is a CONTROLLED MAGNETIC[®] microphone especially designed for high speed intelligibility and exceptional reliability for radio communications, paging, and dispatching systems. The microphone has a high output level, tailored response, and an omnidirectional pickup characteristic. The 450 can be converted to Monitor/Transmit switching with the Shure RK199S Split-Bar Conversion Kit.

Microphone Features:

- Dual impedance (low or high) with impedance switch for convenient changeover
- Finger-tip control bar (locking or non-locking action) to actuate microphone circuit and an external relay or control circuit
- Long-life switch to satisfy rigorous requirements of communications and paging systems
- Sturdy, high impact ARMO-DUR[®] base and microphone case
- Adjustable microphone height
- Dependability – under all operating conditions
- Conversion kit available for Monitor/Transmit switching

PRESS-TO-TALK SWITCH OPERATION

The finger-tip control bar can be used as a locking or nonlocking switch. To use as a nonlocking switch, simply depress the control bar and release after transmission. To use as a locking switch, depress the control bar and pull it forward. To unlock the switch, move the bar back and release.

IMPEDANCE SELECTION

High or low impedance is selected by the switch located on the underside of the microphone base near the cable entry. The microphone is shipped with the switch in the "Hi" position.

The low-impedance connection is recommended where long cable lengths are required or under conditions of severe hum disturbance. The permissible cable length is practically unlimited, since neither response nor level is appreciably affected. Shure A95 Series Line Matching Transformers are available for use in those cases where a low-impedance microphone line is desirable but the associated amplifier has a high-impedance input. These transformers provide a proper impedance match between a 19 to 300 ohm microphone line and a high impedance input, and are available with various input and output connectors.

CONNECTIONS

Figure 1 shows the internal wiring of the 450 microphone.



For unbalanced high- or low-impedance operation, the white cable lead is the "hot" conductor for the microphone circuit; the GREEN cable lead and the shield are connected to the amplifier or chassis ground. Set the impedance switch to the proper position. The RED and BLACK leads control an external relay or switching circuit.

For balanced-line low-impedance operation, with the Impedance Switch in the "LO" position, the WHITE and GREEN cable leads are the "hot" conductors for the microphone circuit; the shield is connected to the amplifier or chassis ground. The RED and BLACK leads control an external relay or switching circuit.

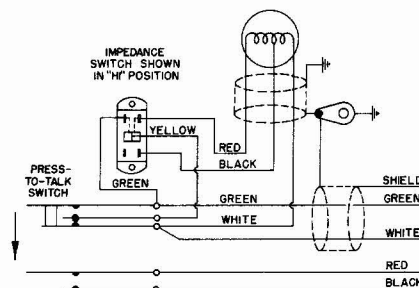

CARTRIDGE CONNECTIONS:
RED & WHITE – HIGH IMPEDANCE
BLACK & WHITE – LOW IMPEDANCE

**INTERNAL CONNECTIONS
FIGURE 1**

OPTIONAL CONVERSION

A split-bar Transmit/Monitor Switch is available for use with transceivers with a receiver squelch circuit. Depressing the Monitor bar disables the receiver squelch circuit so that the operator can determine the presence of signals below the squelch threshold before transmitting. The Monitor switch is either momentary or locking; and the switch can be wired either to ground or to unground the squelch circuit. The Transmit switch bar can be depressed only while the Monitor bar is depressed, thus requiring the operator to verify that the channel is idle before transmitting. The Transmit switch is momentary only and cannot be locked. The Transmit/Monitor Switch Kit is Shure Model RK199S. General microphone wiring instructions are supplied with the kit, but specific transceiver wiring details must be obtained from the transceiver schematic and/or the manufacturer of the unit.

SPECIFICATIONS

Type

CONTROLLED MAGNETIC®

Frequency Response

100 to 10,000 Hz (see Figure 2)

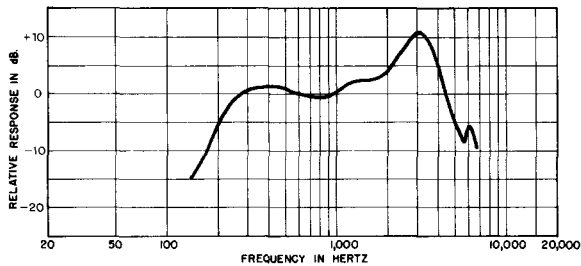

TYPICAL FREQUENCY RESPONSE
FIGURE 2

Polar Pattern

Omnidirectional

Impedance (at 1,000 Hz)

Dual. Microphone rating impedance is 150 ohms (210 ohms actual) and "High"

Load Impedance Range

	Minimum	Recommended
High Impedance	15 kilohms	100 kilohms
Low Impedance	150 ohms	1,000 ohms

Output Level (at 1,000 Hz)

	Impedance	
	High	Low
Open Circuit Voltage*	-53.0 dB (2.24 mV)	-72.0 dB (0.25 mV)

Power Level** -50.5 dB

*0 dB = 1 volt per microbar

**0 dB = 1 milliwatt per 10 microbars

Switches

Press-to-talk Switch—locking or nonlocking operation to actuate microphone circuit and an external relay or control circuit. Microphone circuit normally shorted in high-impedance position and normally open in low-impedance position

Impedance Selection Switch—double-pole, double-throw slide switch in microphone base to provide either high- or low-impedance operation

Cable

2.1m (7 ft) four-conductor, two conductors shielded, nondetachable

Case

Two-tone gray ARMO-DUR®

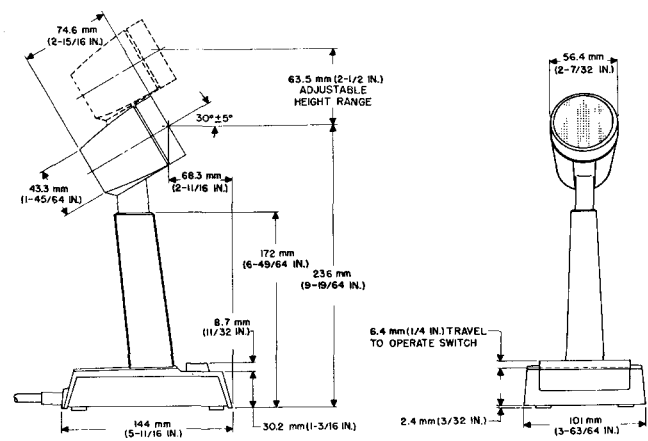

OVERALL DIMENSIONS
FIGURE 3

Net Weight

736 grams (1 lb 10 oz)

Shipping Weight

1020 grams (2 lb 4 oz)

REPLACEMENT PARTS

Cartridge R44D
On-Off Switch RK141S

For additional service or parts information, please contact Shure's Service Department at 1-800-516-2525. Outside the United States, please contact your authorized Shure Service Center.

OPTIONAL CONVERSION PART

Transmit/Monitor Split-Bar Switch Kit RK199S