

# Weller<sup>®</sup> Tech Sheet

## WTCPN Series

### PRODUCT DESCRIPTION

A transformer powered soldering station, complete with a low voltage, temperature controlled soldering pencil. The special Weller "closed loop" method of controlling maximum tip temperature is employed, thereby protecting temperature sensitive components while the grounded tip protects voltage and current sensitive components. The soldering pencil features a stainless steel heater construction, a non-burning silicon rubber cord and a large selection of iron plated tips in sizes from 1/32" diameter to 15/64" diameter with a choice of tip temperature of 600, 700 and 800°F.

A redesigned transformer case features a impact-resistant noryl for durability and protection against accidental damage, a quick connect/disconnect plug for the soldering iron, extra large wiping sponge, tip tray to store extra tips, plus an improved off-on switch with a long-life neon indicator light, a non-heat sinking soldering pencil holder, and a flat flexible 3-wire power cord.

The soldering iron is normally provided with a PTA7 1/16" screwdriver 700°F. The complete station is UL listed.

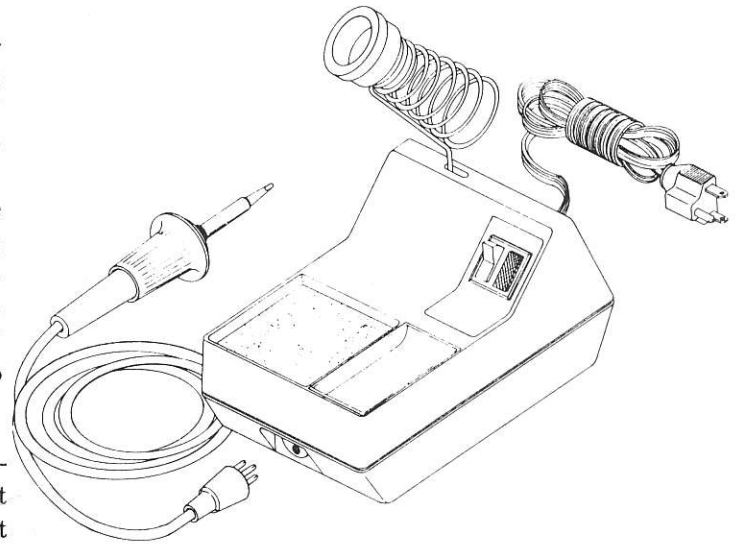

### SPECIFICATION

#### POWER UNIT:

1. Power Input — 120 Volts, 60 Hz 60 Watts
2. Transformer Output Voltage — 24 Volts (Full Load)
3. Power Unit Size — 4-7/16" x 7-3/8" x 3-5/8"
4. Six (6) Foot, 3 Wire Power Cord

#### SOLDERING PENCIL:

1. Soldering Pencil Wattage — 48 Watts
2. Tip Voltage \* To Ground .01 Volts P-P
3. Pencil Weight — 1-3/4 oz. (W/O Cord)
4. Recovery Time (From 100°F Drop)  
W/PTA7 Tip = 11 Sec.

### PRINCIPLE OF OPERATION

When the soldering tip is cold, a ferromagnetic temperature sensor (1) attached to the tip attracts a permanent magnet (2). The magnet movement causes a shorting bar (4) to make contact with a set of isolated electrical contacts (3) thereby supplying power to the heating element through the solder lugs (5). When the tip reaches its idle temperature, the sensor becomes non-magnetic and no longer attracts the magnet. Then a magnetic bushing (6) attracts the magnets causing the shorting bar to break the circuit. In this manner, power to the heating elements is turned on and off automatically.

**CAUTION: TIP IS GROUNDED. DO NOT SOLDER IN AN ENERGIZED CIRCUIT.**

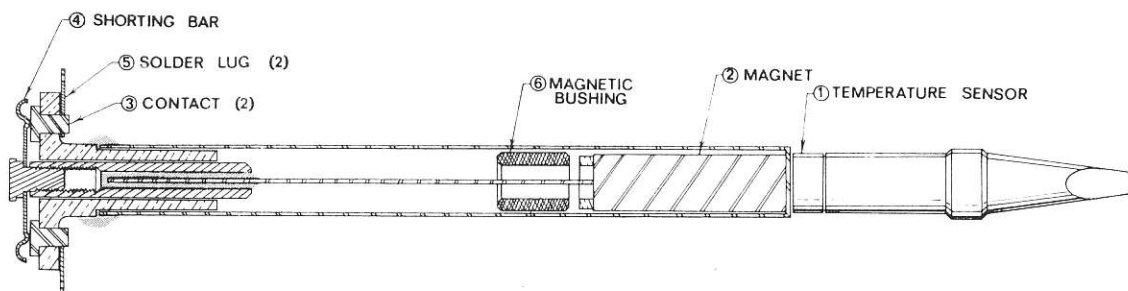

\*Tip ground connected, volt measured w/Type 504 oscilloscope, Tektronic (1 meg. 47 input)

## ABOUT WELLER SOLDERING PENCIL TIPS





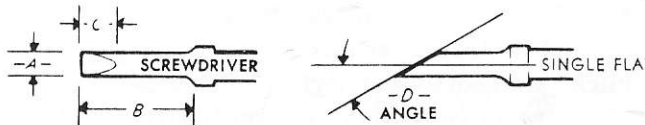

All Weller PT Series soldering pencil tips have been plated with an exclusive process that deposits three (3) protective coatings. The high conductivity copper tips are iron plated, then nickel plated and finally aluminum plated on non-working surfaces. The working surface is then pre-tinned. The aluminum and nickel plating of the tip prevents oxidation of the iron plating which can cause freezing of the tip in the pencil. The aluminum also prevents solder 'creep-up'. Weller's "temperature-sensing" tips have a small ferromagnetic sensing element attached to the tip shank. The sensing element is coded with a number to indicate idle temperature in hundreds of degrees F. Thus a simple change of tips is all that is necessary to adapt the tool to an entirely different temperature range.

### SELECTION OF WELLER PT SERIES TIPS

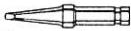
1. Select a tip configuration with the maximum working surface, thickest cross section and shortest reach compatible with the size, the accessibility, and the visual restrictions of the solder joint.
2. Select a tip temperature based on the size of the solder joint, the temperature sensitivity of the components, and the production rate required. Please note that tip life is directly related to tip temperature — the lower the tip temperature the longer the tip life.

Weller industrial soldering tips have heavy iron plating with anti-oxidation coating.

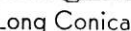

	Catalog Numbers			Description	Dimension			
	600°F	700°F	800°F		A	B	C	D
 Screwdriver	PTA6	PTA7	PTA8	Screwdriver	1/16"	5/8"	3/32"	15°
	PTAA6	PTAA7	PTAA8	Single Flat	1/16"	5/8"	3/32"	30°
 Conical	PTB6	PTB7	PTB8	Screwdriver	3/32"	5/8"	3/32"	22°
	PTBB6	PTBB7	PTBB8	Single Flat	3/32"	5/8"	3/32"	30°
 Single Flat	PTC6	PTC7	PTC8	Screwdriver	1/8"	5/8"	1/8"	22°
	PTCC6	PTCC7	PTCC8	Single Flat	1/8"	5/8"	1/8"	30°
 Long Scwdr.	PTD6	PTD7	PTD8	Screwdriver	3/16"	3/4"	3/16"	22°
	PTDD6	PTDD7	PTDD8	Single Flat	3/16"	3/4"	3/16"	30°
 Long Conical	PTP6	PTP7	PTP8	Conical	1/32"	5/8"	.....	.....
	PTK6	PTK7	PTK8	Long Scwdr.	3/64"	1"	7/16"	7°
 Narrow Scwdr.	PTH6	PTH7	PTH8	Screwdriver	1/32"	5/8"	1/8"	15°
	PTL6	PTL7	PTL8	Long Scwdr.	5/64"	1"	1/2"	7°
	PTF6	PTF7	PTF8	Conical Flat	1/32"	5/8"	1/32"	40°
	PTM6	PTM7	PTM8	Long Scwdr.	1/8"	1"	3/4"	7°
	PTR6	PTR7	PTR8	Narrow Scwdr.	1/16"	5/8"	1/8"	12°
	PTO6	PTO7	PTO8	Long Conical	1/32"	1"	.....	.....
	PTE6	PTE7	PTE8	Screwdriver	15/64"	3/4"	3/16"	22°

### CARE OF WELLER PT SERIES TIPS

1. Keep tip tinned; wipe only before using.
2. Use rosin or activated rosin fluxes. Acid type fluxes will greatly reduce tip life.
3. Remove tip and clean w/suitable cleaner for flux used. The frequency of cleaning will depend on the type of work and usage. Tips in constant use should be cleaned at least once a week.
4. Don't try to clean tip with abrasive materials and never file tip, to do so will greatly reduce tip life.
5. Don't remove excess solder from heated tip before storing. The excess solder will prevent oxidation of the wettable surface when tip is reheated.
6. Dont use anti-seize compounds on tips, they have been plated for oxidation protection.

## TROUBLE SHOOTING GUIDE

**CAUTION: DISCONNECT POWER SUPPLY BEFORE ATTEMPTING ANY REPAIR.**

### 1. Pencil Cold

Check Power Unit for:

1. 120 volts at power supply receptacle.
2. Open in primary circuit by measuring the resistance between the power plug prongs. 12/16 ohms is normal.

Check Pencil for:

1. Temperature sensor (fastened to back end of tip). Pencil will not heat or may overheat if sensor is missing.
2. Heater element resistance — unplug power unit, disassemble handle from pencil by removing three (3) outer perimeter screws, remove wire nuts from heater leads and measure resistance. 12/13 ohms is normal. Replace element if reading is high or low.
3. Switch operation — remove wire nuts from switch leads and connect ohm meter across switch leads. Measure resistance with tip sensor in contact with switch end and with tip removed. Replace switch if readings of zero (0) ohms and infinite ( $\infty$ ) ohms respectively are not obtained.
4. Secondary A. C. voltage — attach A. C. voltmeter to black and white leads coming from power unit to pencil. Plug power unit into 120 V.A.C. and measure secondary voltage. 27 volts is normal. If voltage is zero, check for open in pencil cord by flexing cord. Watch meter for indication of voltage, replace cord if necessary. If cord is okay, unplug power unit and measure secondary circuit resistance (between black and white leads). 1.0/2.0 ohms is normal, if infinite ( $\infty$ ) ohms, check for open connection in power unit.

### 2. Pencil Too Hot

Check pencil as above.

### 3. Excessive Tip Voltage

Check Power Unit and Pencil for:

1. Ground continuity from tip to power cord plug ground prong.
2. Power supply receptacle ground continuity; do not allow the use of "cheater" plugs.

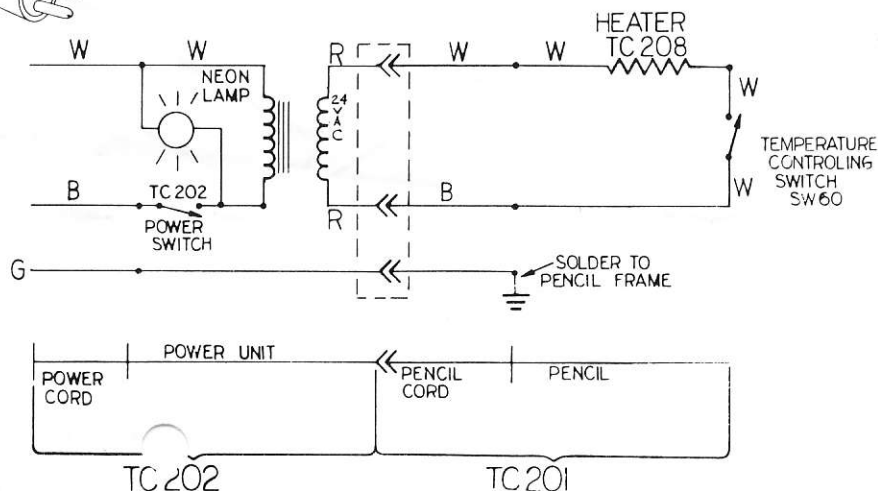
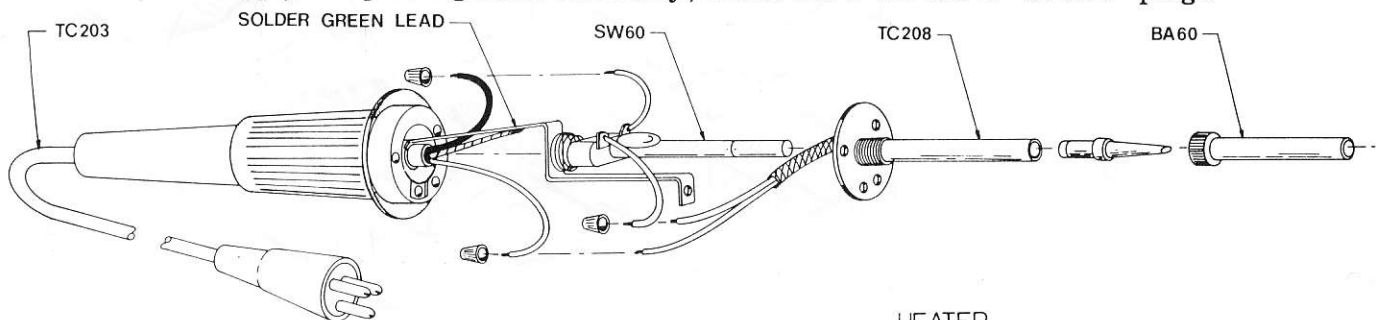

## REPAIR PARTS LIST

Key	Part No.	Description
1.	TC208	Heater
2.	SW60	Switch Assembly
3.	TC203	Cord Set W/Handle
4.	TC207	Switch/light Power Unit (WTCPN)

## REPLACEMENT PARTS LIST

Key	Part No.	Description
	TC201	Soldering Pencil, includes BA60 and PTA7 tip
5.	BA60	Barrel Nut Assembly
6.	TC205	Sponge (10 per package)
7.	TC204	Iron Holder W/Funnel
8.	TC202	Power Unit Only, Includes Sponge and Iron Holder for WTCPN
9.	TC206	Tip Tray

