

THE "HANDY CAL" CA11/CA12 CALIBRATORS

OGUMA Yoshio *1 NAGATSUKA Makoto *1 YAMAMOTO Tadashi *1 AOYAMA Yutaka *1

We have developed two models of battery-operated hand-held calibrators, the CA11 and CA12, which are designed for simple operation and high performance. The voltage and current calibrator CA11 can supply and measure signals of up to 30 VDC and 24 mA DC and has a current SINK function. The temperature calibrator CA12 generates a signal that simulates the signals of six types of thermocouples (TCs) as well as an resistance temperature detector (RTD), and also acts as a thermometer for the TC and RTD sensors.

This paper describes the design features and structure of these two calibrators.

INTRODUCTION

The Model 2422 Portable Calibrator developed in 1988 was widely adopted as a DC voltage and current calibrator for field-use and applied in all kinds of industries that require maintenance and inspection of instrumentation. The next calibrator, the CA100 Compact Cal developed in 1996 (cf. [1]), offers functions and a performance level that were enhanced by adding the RTD and frequency generating functions and has been well reputed as a multi-functional field-use calibrator. These instruments have an all-in-one design that incorporates the many functions necessary for calibrating and checking various object instruments in the field. Besides multi-functional instruments, there is also strong demand for compact and lightweight, low-cost, dedicated type instruments with only one or two functions. Such instruments restrict the functions to only those necessary for the particular instrument or job at hand in order to simplify their operations and make them easy to understand.

The latest release, the CA10 series hand-held calibrators developed by Yokogawa M&C Corporation fill this demand. They come equipped with functions that apply specifically to the instrument or system for which they are to be exclusively used, making their operations even simpler and easier to understand. These instruments are also compact, lightweight and low-cost.

The calibrators are designed so that the basic operations are easy to carry out without needing to consult the instruction manual. At the same time, performance was improved so that the basic



Figure 1 External View of CA11 Calibrator

*1 Yokogawa M&C Corporation

requirements for the particular use are sufficiently achieved even though the functions are separated.

The following two types of calibrators have been developed as the CA10 series:

(1) CA11 voltage and current calibrator

This generates or measures (as selected) 100-mV to 30-V voltages and/or 20-mA range currents. It also has a 20-mA SINK function, and achieves a basic accuracy of 0.05% to 0.1%.

(2) CA12 temperature calibrator

This generates and/or measures (as selected) 100 mV, six types of TCs (K, E, J, T, N, and R), 400 Ω, and RTD range. The CA12 incorporates the reference junction-temperature compensation function and also includes the thermometer function for the multiple TCs and the RTD.

Both types of calibrators run on batteries but also come with an AC adapter. Figure 1 shows an external view of the CA11 calibrator. The CA12 calibrator also has the same shape.

Other than these two, the CA13 frequency calibrator for pulse generation and measurement has been added as the CA10 series calibrators.

HISTORY OF DEVELOPMENT OF STANDARD VOLTAGE AND CURRENT GENERATORS/CALIBRATORS

Before introducing these two CA10 series calibrators, we

would like to briefly trace the history relating to Yokogawa's product development of standard voltage and current generators (calibrators). Table 1 shows the major products that have been released over the years, and describes their main features.

The history of the standard voltage generators in Yokogawa dates back to 1964, the days when vacuum tubes were still used to control high voltages. At that time, a full-transistorized product that can output up to 1000 V with 0.02% accuracy was developed. Many products have been developed since then as shown in Table 1. The products were first referred to as standard voltage and current generators, but are now referred to as calibrators in view of the increasing importance of traceability and calibration. These products were first developed in a bench-top form due to the fact that they were mainly used indoors at that time. The demand for portable calibrators for field use came later in line with the increase in portability of other products. As technology has advanced, the development of calibrator products has split into two main areas — bench-top types for achieving higher accuracy and more compact types for portable use.

The standard voltage and current generator is composed of basic components and digital elements. The basic components include a high-resolution D-A converting section for arbitrary setting of output at various digits, an output control section for controlling wide ranges of voltage or current outputs, a reference voltage element, divider resistors, and so on. The digital elements include a CPU for controlling the man-machine interface and the operations of all circuits, communications, and so on. The history of product developments encompasses the history of these components within it. The D-A converter that was first composed of voltage dividers using resistors has been replaced with a pulse-width modulation (PWM) system of theoretically good linearity. In 1979, microprocessors were first installed, increasing the functionality through, for example, temperature setting with thermocouple-equivalent outputs, and making it possible to communicate via GP-IB interface. In addition, a battery-driven (Ni-Cd) type product was developed in 1975 and the production of the first real portable calibrator began in 1988.

The CA11 and CA12 calibrators have been developed based on these advancements and experience, specifically by using the resources of the CA100 calibrator and Yokogawa's hand-held DMM.

DESIGN CONCEPT, BASIC CONFIGURATION AND FEATURES

Simple operation and ease of use were taken as the basic design concept for the development of CA10 series calibrators. The following features were adopted to achieve this, as well as to enhance the performance and reliability, achieve a smaller and lighter product and reduce the overall cost.

(1) Rotary switch range selector

It was determined that a rotary switch similar to that of the hand-held DMM be used as the range selector. The mechanism of the PCB switch already proven in Yokogawa's DMM, was utilized for the switch part as a means of reducing

Table 1 History of Yokogawa's Standard Generator Products

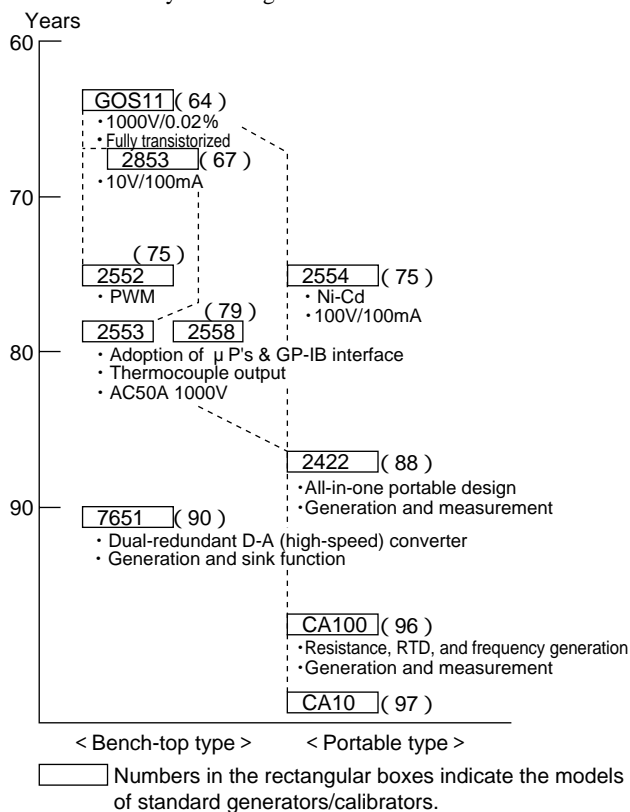

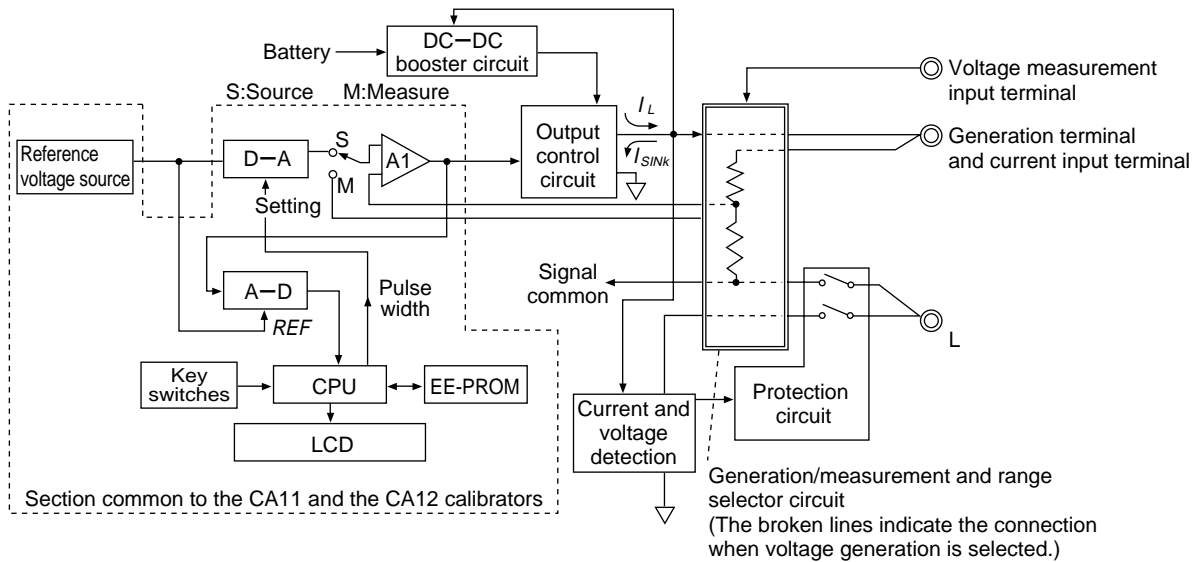

Figure 2 Block Diagram for the CA11 Calibrator

cost and improving reliability. The adoption of the rotary switch selector allows the user to see the selection ranges at a glance. In addition, if the user uses the same range repeatedly, the user need not set the range each time and use the calibrator as if it were an instrument dedicated for that range.

- (2) Setup of value to be generated using the up and down keys
To setup a value to be generated, these calibrators have improved upon the popular up and down key method used in models 2422 and CA100, that allows the user to easily set the desired value for each digit. The key positions for each digit are aligned under the LCD display for easy understanding. Further, step output ranges are provided for the 4- to 20-mA output so that the adjustments are made from 4 mA ↔ 8 mA ↔ 12 mA ↔ 16 mA ↔ 20 mA outputs with each touch operation.
- (3) Slide switch for selection of generation or measurement
This allows the selection of generation (SOURCE) or measurement (MEASURE) to be known at a glance.
- (4) Enhancement of voltage and current protection circuits
Since generation and measurement functions are both included, a protection circuit is incorporated for the application of voltages to and output short-circuiting of the generation terminals due to incorrect wiring and so on.
- (5) Improvement in battery life by reducing current consumption
The low current consumption CMOS one-chip microprocessor was employed in the CPU. Each circuit was also designed to reduce power consumption and to have an automatic power-off function. In addition, a low-loss output control system was adopted in the CA11 calibrator.
- (6) Adoption of EEPROM for internal adjustment
The digital correction method in which the correction values were stored in an EEPROM was employed for internal adjustment. This allows re-adjustment to be made using the

front-key if it needs to be regularly adjusted to improve maintainability.

- (7) Enhancement of functions by shared use of DIP switches
The calibrators for normal use come with both a simplified front panel and DIP switches that provide more advanced functions. The CA11 calibrator has a DIP switch for selecting the sweep function, and both the CA11 and the CA12 have a DIP switch for selecting auto power-off.
- (8) Common use and simplification of circuit components
As described later, the configuration was devised so that circuit components for both generation and measurement are used in common as far as possible in order to reduce the number of components and the consequent size of the instrument.

CONFIGURATION

Circuitry and Common Parts

Figures 2 and 3 show the circuit configuration for the CA11 and the CA12 calibrators respectively.

The D-A converting section uses a multiplier D-A converter that uses the PWM method and the output is set from the CPU with a pulse width equivalent to 16 bits, which includes 12 bits in the upper part and 4 bits in the lower part. The linearity of the D-A converting section achieves a value within 0.002% of the full scale. For the A-D converter, a CMOS with a resolution of 20 bits using the $\Delta\Sigma$ conversion method is adopted. For measurement, the automatic-zero correcting method is employed over all ranges in order to carry out zero-offset correction for every measurement sample including that of the preamplifier. An 8-bit CMOS one-chip microprocessor with a built-in LCD drive is used for the CPU to reduce current consumption as well as to directly connect the interfaces for the operation keys, switches, A-D converter, EEPROM, and so on, to the I/O port. This effectively eliminates

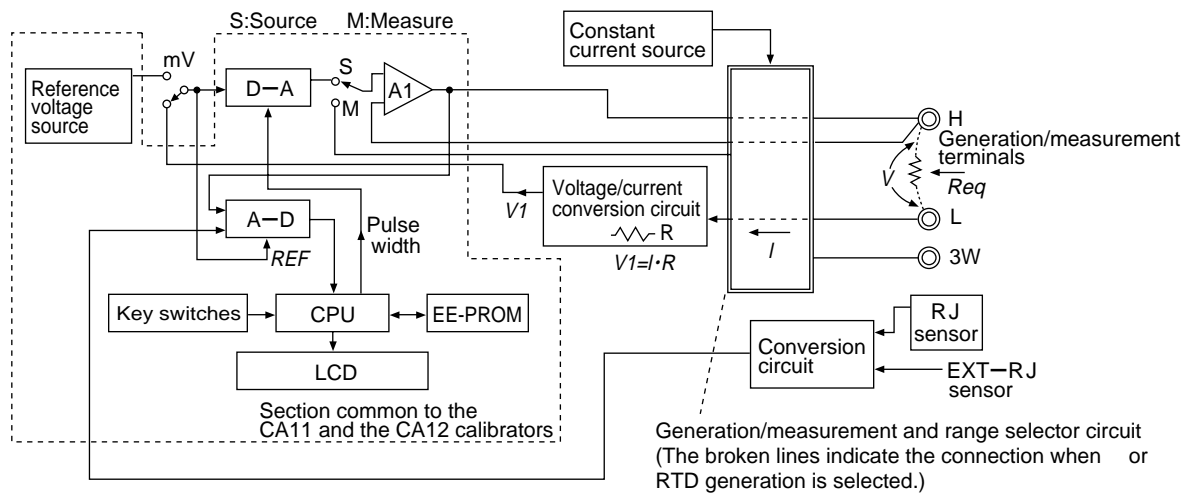

Figure 3 Block Diagram for the CA12 Calibrator

peripheral elements and makes the body smaller.

The internal firmware must be common for both types of calibrator and is selected for each type on the basis of the I/O port selection. In both types of calibrator, key elements of generation and measurement, such as the reference voltage element, reference resistor, voltage divider using resistors, and I/O high precision amplifier, are used commonly by switching between Source and Measure. This reduces the number of elements and, except for the circuits specific to each calibrator (described below), configures the sections common to both calibrators with the same circuits and elements.

Voltage and Current Type

When source output (positive voltage and current output) is selected, the error amplifier A1 is maintained for the output control circuit and the DC-DC converter output stabilized as a result. The output is controlled so that the feedback voltage from the output selection circuit becomes equal to the D-A converter output. This involves dividing the output voltage by the voltage range and feeding back the voltage drop in the output current shunt to the input side of the A1 amplifier of the output selection circuit. In this case, the service life of the battery should be improved by limiting unnecessary power consumption. This can be achieved by controlling the output voltage of the DC-DC converter so that the voltage drop in the output stabilizing elements takes the minimum value required for control even if the output voltage varies. The current SINK function controls the current sunk from the power supply applied externally using the output control circuit.

The protection circuit detects the current through the output terminal and the voltage across the output terminals, and cuts off the output circuit if the current and/or voltage exceed their specified values. Although a relay is normally used for the on/off element, this calibrator uses MOSFET so that the inputs of both polarities can be cut off at a high speed.

Temperature Type

The resistance and RTD-equivalent resistance generation system is the same as that adopted in the CA100 calibrator. This system does not actually incorporate resistors but employs a simulation method to generate resistance values between output terminals. This involves generating a voltage equivalent to the resistance value generated in accordance with the current applied from the resistance-measuring system or RTD thermometer. If the input current is expressed as I , then the output of the current-voltage conversion circuit is expressed as $V1 = I \times R$ (R being the reference resistance in the current-voltage conversion circuit). The following equations are also obtained, assuming that the conversion coefficient of the D-A converter with the set pulse width (= output/input) is expressed as k , the output voltage (voltage between terminals) as V , and the simulative resistance obtained between the output terminals as Req :

$$V = V1 \times k = I \times R \times k$$

$$Req = V/I = k \times R$$

From the above operating theory, the input current I is limited to its maximum value. Thus the input current for this calibrator is specified as 2 mA or less. If the value of I is lower, there are no restrictions in operation but the ratio, in which the system voltage offset produces an error, increases. For example, if the offset is 50 μ V, then the resistance error is 0.5 Ω at the resistance measuring current of 0.1 mA. In this calibrator, this offset voltage is suppressed to 50 μ V or less. The calibrator also has a fast response rate that enables it to accept scanner-type temperature measuring instruments. Its output response after a current applied is designed to be about 20 ms.

The sensor for the built-in reference junction compensating circuit for thermometers using thermocouples consists of a thermistor sensor that detects the temperature of the input terminal part. For the thermocouple-equivalent mV output, if the object instrument incorporates the reference junction compensation, it is necessary to detect the reference junction temperature of the object instrument with an RJ sensor and to

send the output after correcting the thermo-electromotive force for that temperature. In such a case, a function with which the correction can be simply made using this built-in sensor, in addition to an external sensor, is also provided (selected by the DIP switch).

CONSTRUCTION

The development of the new calibrators also involved developing new mold cases. The layout, color arrangement, and display items were all considered in the design on the basis of ease of use. Their size and shape were made equivalent to that of conventional 4.5-digit hand-held DMMs to make obvious their convenience factor. The input terminal section has safety terminal construction. The temperature-type calibrator comes with a terminal adapter that enables thermocouples or RTD sensors to be directly connected.

During development, it was also decided that measuring instrument products of Yokogawa M&C Corporation be made available in different colors. The CA10 series calibrators have been made available in these new colors since the first shipment, and main existing models are gradually being produced in the new colors.

CONCLUDING REMARKS

We have outlined the purpose of development as well as the functions, features, and internal circuits of the CA10 series calibrators. We anticipate that these calibrators will be used widely as field calibrators for all kinds of industrial instruments that handle voltages, currents, or temperatures, not to mention instruments related to maintenance and inspection.

In addition, we have expanded the CA10 series by developing the CA13 frequency-type calibrator for pulse outputs. The CA13 calibrator can generate and measure pulse signals of 1 Hz to 11 kHz as well as contact signals other than voltage pulses. The aim of this type of calibrator is to expand the range of applications to not only process fields but to also factory automation fields, by incorporating advanced functions for generation, such as arbitrary pulse setup, two-phase pulse output whose phase difference is 90 degrees, and variable duty ratio. ◆

REFERENCE

1. OMURA H., et al.; "Model CA100 'Compact CAL' Calibrator," Yokogawa Technical Report, English Edition, No. 24, pp. 15-19 (1997)

